

48783

# Radio - BUILD A STUN GUN

\$1.95 SEPT. 1986  
IN CANADA \$2.50

# Electronics®

TECHNOLOGY - VIDEO - STEREO - COMPUTERS - SERVICE

## BUILD THIS STUN GUN

Easy-to-build  
electronic protection

A  
**GERNSBACK**  
PUBLICATION

## COMMUNICATIONS

From DC to microwave

## TV DESCRAMBLING

Practical PLL circuits

## THE WORLD

## ABOVE 800 MHz

New regulations and services

## OSCILLATORS

Design your own

## FROM BRAINSTORM TO BREADBOARD

How to design electronic projects

### PLUS:

- ★ Video News
- ★ Satellite TV
- ★ PC Service
- ★ Antique Radios
- ★ Robotics
- ★ **COMPUTERDIGEST**



# 100 MHz scope, counter, timer, multimeter: All one integrated system.

**100 MHz dual time base scope.**

3.5 ns risetime; sweeps from 0.5 s to 5 ns/div; alternate sweep;  $\pm 2\%$  vertical/horizontal accuracy; vertical sensitivity to 2 mV/div @ 90 MHz.

**9-digit fluorescent display.**

Digitally accurate readouts accompany the CRT waveform. Error messages and prompts also appear on the display.

**Dc volts and ac coupled true RMS volts.** Measured through the Ch 1 scope input.

**Gated measurements.** Use the scope's intensified marker to measure frequency, period, width and to count events within specified portions of the signal.

**Auto-ranged, auto-averaged counter/timer.**

Frequency, period, width, delay time,  $\Delta$ -time, plus totalize to more than 8 million events — with 7 digits plus exponent displayed.

**Auto-ranged DMM.**

Use floating DMM side inputs with up to 5000-count resolution. Get precise readouts of average dc and true RMS voltage. Measure resistance from milliohms to gigohms.

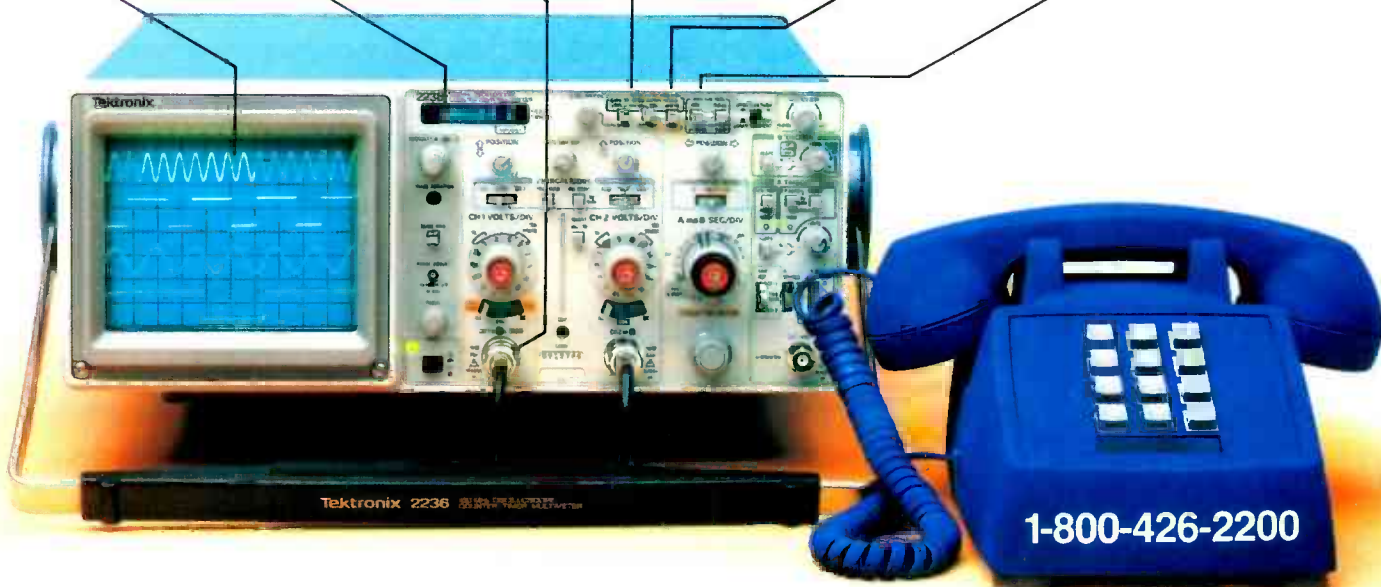

**Now make measurements faster, easier, with greater accuracy and user confidence.**

The Tek 2236 makes gated counter measurements, temperature, time, frequency, resistance and voltage measurements push-button easy. You see results concurrently on the 9-digit numeric readout and CRT display.

Its complete trigger system includes pushbutton trigger view, plus peak-to-peak auto, TV line, TV field, single sweep and normal modes.

At just \$2650\*, the 2236 includes the industry's first 3-year warranty on all parts and labor, including the CRT.

**Integrated measurement system. 3-year warranty. 15-day return policy. And expert advice. One free call gets it all!** You can order, or obtain literature, through the Tek National Marketing Center. Technical personnel, expert in scope applications, can answer your questions and expedite delivery. Direct orders include probes, operating

manual, 15-day return policy, full warranty and worldwide service back-up.

**Order toll-free:  
1-800-426-2200  
Extension 57**

In Oregon call collect:  
(503) 627-9000 Ext. 57  
Or write Tektronix, Inc.  
P.O. Box 1700  
Beaverton, OR 97075

**Tektronix**  
COMMITTED TO EXCELLENCE

# SEPTEMBER '86

**Radio-  
Electronics**<sup>®</sup>  
Electronics publishers since 1908

Vol. 57 No. 9

## SPECIAL SECTION:

- 45 COMMUNICATIONS: FROM DC TO MICROWAVE**  
Take a guided tour through the communications spectrum.  
**Josef Bernard**
- 49 THE NEW WORLD OF COMMUNICATIONS**  
A look at the world above 800 MHz, and the new regulations and services you'll be seeing.  
**Benn Kobb**

## BUILD THIS

- 41 STUN GUN**  
Protect yourself with 75,000 volts.  
**Robert Grossblatt and Robert Iannini**
- 44 PHONY BURGLAR ALARM**  
This "electronic scarecrow" makes your house look like it's protected with hi-tech electronics. **Michael Ringenberger**
- 69 PC SERVICE**  
Use our exclusive direct-etch foil patterns to make circuit boards for this month's projects.

## TECHNOLOGY

- 6 VIDEO NEWS**  
Inside the fast-changing video scene.  
**David Lachenbruch**
- 72 SATELLITE TV**  
Test equipment for satellite TV.  
**Bob Cooper, Jr.**
- 61 FROM BRAINSTORM TO BREADBOARD**  
The smart way to design electronics projects.  
**David J. Sweeny**
- 74 ROBOTICS**  
Position sensors for robots. **Mark J. Robillard**

## CIRCUITS AND COMPONENTS

- 54 TV SIGNAL DESCRAMBLING**  
Part 4. Practical descrambling circuits using PLL's. **William Sheets and Rudolf F. Graf**
- 58 HOW TO DESIGN OSCILLATOR CIRCUITS**  
Part 3. A look at R-C oscillators. **Joseph J. Carr**
- 64 THE VERSATILE 4007**  
It may be the world's most versatile CMOS IC.  
**Ray Marston**
- 78 SERVICE CLINIC**  
Customer psychology for servicing TV's.  
**Jack Darr**
- 78 SERVICE QUESTIONS**  
Solutions to servicing problems.
- 92 DRAWING BOARD**  
Correct that software! **Robert Grossblatt**

## RADIO

- 88 ANTIQUE RADIOS**  
Antique headphones and speakers and how to troubleshoot them.  
**Richard D. Fitch**
- 84 COMMUNICATIONS CORNER**  
Transmitters Vs. Receivers: the war over RFI  
**Herb Friedman**

## COMPUTERS

- Following page 72
- COMPUTER DIGEST**  
CB scanners, souped-up PC's and optical-disk technology.

## EQUIPMENT REPORTS

- 24 Soar Model 3430 DMM**
- 32 Vector SMT Training Kit**

## DEPARTMENTS

- 114 Advertising and Sales Offices**
- 114 Advertising Index**
- 12 Ask R-E**
- 115 Free Information Card**
- 14 Letters**
- 95 Market Center**
- 34 New Products**
- 4 What's News**

**RADIO-ELECTRONICS, (ISSN 0033-7862)** Sept., 1986. Published monthly by Gernsback Publications, Inc., 500-B Bi-County Boulevard, Farmingdale, NY 11735 Second-Class Postage paid at Farmingdale, NY and additional mailing offices. Second-Class mail registration No. 9242 authorized at Toronto, Canada. One-year subscription rate U.S.A. and possessions \$16.97, Canada \$22.97, all other countries \$25.97. Subscription orders payable in US funds only, international postal money order or check drawn on a U.S.A. bank. Single copies \$1.95 ©1986 by Gernsback Publications, Inc. All rights reserved. Printed in U.S.A.

**POSTMASTER:** Please send address changes to RADIO-ELECTRONICS, Subscription Dept., Box 55115, Boulder, CO 80321-5115.

A stamped self-addressed envelope must accompany all submitted manuscripts and/or artwork or photographs if their return is desired should they be rejected. We disclaim any responsibility for the loss or damage of manuscripts and/or artwork or photographs while in our possession or otherwise.

# COVER 1



We certainly hope you don't run into the same situation that our cover model is in, but if you do, we hope you have some protection. We're not going to tell you that a stun gun is your best protection, or that carrying a stun gun should make you feel confident in unsafe situations. But we think it's better to have some form of defense than none. The stun gun is a non-lethal weapon that can stop an attacker with its 75,000-volt discharge.

The stun gun is not a toy. It is a dangerous project and it is not recommended for beginners. To find out how to build yours, turn to page 41.

# NEXT MONTH

## THE OCTOBER ISSUE IS ON SALE SEPTEMBER 2

**BUILD A SATELLITE-TV DESCRAMBLER**  
To decode Teletext-Mast programming.

**BUILD AN EPROM PROGRAMMER**  
Choose the features you need most.

**SATELLITE JAMMING**  
A look at its ominous potential.

As a service to readers, RADIO-ELECTRONICS publishes available plans or information relating to newsworthy products, techniques and scientific and technological developments. Because of possible variances in the quality and condition of materials and workmanship used by readers, RADIO-ELECTRONICS disclaims any responsibility for the safe and proper functioning of reader-built projects based upon or from plans or information published in this magazine.

Since some of the equipment and circuitry described in RADIO-ELECTRONICS may relate to or be covered by U.S. patents, RADIO-ELECTRONICS disclaims any liability for the infringement of such patents by the making, using, or selling of any such equipment or circuitry, and suggests that anyone interested in such projects consult a patent attorney.

## Radio- Electronics

Hugo Gernsback (1884-1967) founder  
M. Harvey Gernsback,  
editor-in-chief, emeritus

Larry Steckler, EHF, CET, editor-in-chief  
and publisher

### EDITORIAL DEPARTMENT

Art Kleiman, editorial director  
Brian C. Fenton, managing editor  
Carl Laron, WB2SLR, associate editor  
Jeffrey K. Holtzman,  
assistant technical editor  
Robert A. Young, assistant editor  
Julian S. Martin, editorial associate  
Byron G. Wels, editorial associate  
M. Harvey Gernsback,  
contributing editor  
Jack Darr, CET, service editor  
Robert F. Scott,  
semiconductor editor  
Herb Friedman,  
communications editor  
Bob Cooper, Jr. satellite-TV editor  
Robert Grossblatt, circuits editor  
David Lachenbruch,  
contributing editor  
Richard D. Fitch,  
contributing editor  
Mark J. Robillard, robotics editor  
Teri Scaduto Wilson, editorial assistant  
Judith Kaplan, editorial assistant

### PRODUCTION DEPARTMENT

Ruby M. Yee, production director  
Robert A. W. Lowndes,  
editorial production  
Andre Duzant, technical illustrator  
Karen Tucker, advertising production  
Geoffrey S. Weil, production traffic

### CIRCULATION DEPARTMENT

Jacqueline P. Cheeseboro,  
circulation director  
Wendy Alanko,  
circulation analyst  
Theresa Lombardo,  
circulation assistant

Cover photo by Robert Lewis

Typography by Mates Graphics

Radio-Electronics, Gernsback Publications, Inc., Executive Offices, 500-B Bi-County Blvd., Farmingdale, NY 11735, 516-293-3000

Radio-Electronics is indexed in *Applied Science & Technology Index* and *Readers Guide to Periodical Literature*.

Microfilm & Microfiche editions are available. Contact circulation department for details.

Advertising Sales Offices listed on page 114.



# NEW! Lower Price Scanners

Communications Electronics™, the world's largest distributor of radio scanners, introduces new lower prices to celebrate our 15th anniversary.

## Regency® MX7000-GR

List price \$699.95/CE price \$469.95  
**10-Band, 20 Channel • Crystalless • AC/DC**  
Frequency range: 25-550 MHz, continuous coverage and 800 MHz, to 1.3 GHz, continuous coverage. The Regency MX7000 scanner lets you monitor Military, Space Satellites, Government, Railroad, Justice Department, State Department, Fish & Game, Immigration, Marine, Police and Fire Departments, Broadcast Studio Transmitter Links, Aeronautical AM band, Aero Navigation, Paramedics, Amateur Radio, plus thousands of other radio frequencies most scanners can't pick up. The Regency MX7000 is the perfect scanner to receive the exciting 1.2 GHz, amateur radio band.

## Regency® Z60-GR

List price \$299.95/CE price \$179.95/SPECIAL  
**8-Band, 60 Channel • No-crystal scanner**  
Bands: 30-50, 88-108, 118-136, 144-174, 440-512 MHz. The Regency Z60 covers all the public service bands plus aircraft and FM music for a total of eight bands. The Z60 also features an alarm clock and priority control as well as AC/DC operation. Order today.

## Regency® Z45-GR

List price \$259.95/CE price \$159.95/SPECIAL  
**7-Band, 45 Channel • No-crystal scanner**  
Bands: 30-50, 118-136, 144-174, 440-512 MHz. The Regency Z45 is very similar to the Z60 model listed above however it does not have the commercial FM broadcast band. The Z45, now at a special price from Communications Electronics.

## Regency® RH250B-GR

List price \$659.00/CE price \$329.95/SPECIAL  
**10 Channel • 25 Watt Transceiver • Priority**  
The Regency RH250B is a ten-channel VHF land mobile transceiver designed to cover any frequency between 150 to 162 MHz. Since this radio is synthesized, no expensive crystals are needed to store up to ten frequencies without battery backup. All radios come with CTCSS tone and scanning capabilities. A monitor and night/day switch is also standard. This transceiver even has a priority function. The RH250 makes an ideal radio for any police or fire department volunteer because of its low cost and high performance. A 60 Watt VHF 150-162 MHz, version called the RH600B is available for \$454.95. A UHF 15 watt version of this radio called the RU150B is also available and covers 450-482 MHz, but the cost is \$449.95.

## NEW! Bearcat® 50XL-GR

List price \$199.95/CE price \$114.95/SPECIAL  
**10-Band, 10 Channel • Handheld scanner**  
Bands: 29.7-54, 136-174, 406-512 MHz. The Uniden Bearcat 50XL is an economical, hand-held scanner with 10 channels covering ten frequency bands. It features a keyboard lock switch to prevent accidental entry and more. Also order part # BP50 which is a rechargeable battery pack for \$14.95, a plug-in wall charger, part # AD100 for \$14.95, a carrying case part # VC001 for \$14.95 and also order optional cigarette lighter cable part # PS001 for \$14.95.

## NEW! Scanner Frequency Listings

The new Fox scanner frequency directories will help you find all the action your scanner can listen to. These new listings include police, fire, ambulances & rescue squads, local government, private police agencies, hospitals, emergency medical channels, news media, forestry radio service, railroads, weather stations, radio common carriers, AT&T mobile telephone, utility companies, general mobile radio service, marine radio service, taxi cab companies, tow truck companies, trucking companies, business repeaters, business radio (simplex) federal government, funeral directors, veterinarians, buses, aircraft, space satellites, amateur radio, broadcasters and more. Fox frequency listings feature call letter cross reference as well as alphabetical listing by licensee name, police codes and signals. All Fox directories are \$14.95 each plus \$3.00 shipping. State of Alaska-RL019-1; State of Arizona-RL025-1; Baltimore, MD/Washington, DC-RL024-1; Buffalo, NY/Erie, PA-RL009-2; Chicago, IL-RL014-1; Cincinnati/Dayton, OH-RL006-2; Cleveland, OH-RL017-1; Columbus, OH-RL003-2; Dallas/Ft. Worth, TX-RL013-1; Denver/Colorado Springs, CO-RL027-1; Detroit, MI/Windsor, ON-RL008-3; Fort Wayne, IN/Lima, OH-RL001-1; Hawaii/Guam-RL015-1; Houston, TX-RL023-1; Indianapolis, IN-RL022-1; Kansas City, MO/KS-RL011-2; Long Island, NY-RL026-1; Los Angeles, CA-RL016-1; Louisville/Lexington, KY-RL007-1; Milwaukee, WI/Waukegan, IL-RL021-1; Minneapolis/St. Paul, MN-RL010-2; Nevada/E. Central CA-RL028-1; Oklahoma City/Lawton, OK-RL005-2; Orlando/Daytona Beach, FL-RL012-1; Pittsburgh, PA/Wheeling, WV-RL029-1; Rochester/Syracuse, NY-RL020-1; San Diego, CA-RL018-1; Tampa/St. Petersburg, FL-RL004-2; Toledo, OH-RL002-3. New editions are being added monthly. For an area not shown above call Fox at 800-543-7892. In Ohio call 800-621-2513.

## NEW! Regency® HX1500-GR

List price \$369.95/CE price \$239.95  
**11-Band, 55 Channel • Handheld/Portable**  
**Search • Lockout • Priority • Bank Select**  
**Sidelit liquid crystal display • EAROM Memory**  
**Direct Channel Access Feature • Scan delay**  
Bands: 29-54, 118-136, 144-174, 406-420, 440-512 MHz. The new handheld Regency HX1500 scanner is fully keyboard programmable for the ultimate in versatility. You can scan up to 55 channels at the same time including the AM aircraft band. The LCD display is even sidelit for night use. Includes belt clip, flexible antenna and earphone. Operates on 8 1.2 Volt rechargeable Ni-cad batteries (not included). Be sure to order batteries and battery charger from accessory list in this ad.

## Bearcat® 100XL-GR

List price \$349.95/CE price \$203.95/SPECIAL  
**9-Band, 16 Channel • Priority • Scan Delay**  
**Search • Limit • Hold • Lockout • AC/DC**  
Frequency range: 30-50, 118-174, 406-512 MHz. The world's first no-crystal handheld scanner now has a LCD channel display with backlight for low light use and aircraft band coverage at the same low price. Size is 1 3/4" x 7 1/2" x 2 1/2". The Bearcat 100XL has wide frequency coverage that includes all public service bands (Low, High, UHF and "T" bands), the AM aircraft band, the 2-meter and 70 cm. amateur bands, plus military and federal government frequencies. Wow... what a scanner! Included in our low CE price is a sturdy carrying case, earphone, battery charger/AC adapter, six AA Ni-cad batteries and flexible antenna. Order your scanner now.

## Bearcat® 210XW-GR

List price \$339.95/CE price \$209.95/SPECIAL  
**8-Band, 20 Channel • No-crystal scanner**  
**Automatic Weather • Search/Scan • AC/DC**  
Frequency range: 30-50, 136-174, 406-512 MHz. The new Bearcat 210XW is an advanced third generation scanner with great performance at a low CE price.

## NEW! Bearcat® 145XL-GR

List price \$179.95/CE price \$102.95/SPECIAL  
**10 Band, 16 channel • AC/DC • Instant Weather**  
Frequency range: 29-54, 136-174, 420-512 MHz. The Bearcat 145XL makes a great first scanner. Its low cost and high performance lets you hear all the action with the touch of a key. Order your scanner from CE today.

## TEST ANY SCANNER

Test any scanner purchased from Communications Electronics™ for 31 days before you decide to keep it. If for any reason you are not completely satisfied, return it in original condition with all parts in 31 days, for a prompt refund (less shipping/handling charges and rebate credits).

## NEW! Bearcat® 800XL-GR

List price \$499.95/CE price \$317.95  
**12-Band, 40 Channel • No-crystal scanner**  
**Priority control • Search/Scan • AC/DC**  
Bands: 29-54, 118-174, 406-512, 806-912 MHz. The Uniden 800XL receives 40 channels in two banks. Scans 15 channels per second. Size 9 1/4" x 4 1/2" x 1 1/2".

## OTHER RADIOS AND ACCESSORIES

Panasonic RF-2600-GR Shortwave receiver..... \$179.95  
RD95-GR Uniden Remote mount Radar Detector... \$128.95  
RD55-GR Uniden Visor mount Radar Detector... \$98.95  
RD9-GR Uniden "Passport" size Radar Detector... \$199.95  
BC-WA-GR Bearcat Weather Alert™..... \$49.95  
DX1000-GR Bearcat shortwave receiver SALE..... \$349.95  
PC22-GR Uniden remote mount CB transceiver... \$99.95  
PC55-GR Uniden mobile mount CB transceiver... \$59.95  
R1060-GR Regency 10 channel scanner SALE..... \$92.95  
MX3000-GR Regency 30 channel scanner..... \$229.95  
XL156-GR Regency 10 channel scanner..... \$139.95  
UC102-GR Regency VHF 2 ch. 1 Watt transceiver... \$124.95  
P1405-GR Regency 5 amp regulated power supply... \$69.95  
P1412-GR Regency 12 amp reg. power supply... \$164.95  
MA256-GR Drop-in charger for HX1200 & HX1500... \$84.95  
MA518-GR Wall charger for HX1500 scanner..... \$14.95  
MA516-GR Carrying case for HX1500 scanner..... \$14.95  
MA257-GR Cigarette lighter cord for HX1212/1500... \$19.95  
MA917-GR Ni-Cad battery pack for HX1200... \$34.95  
SMMX7000-GR Svc. man. for MX7000 & MX5000... \$19.95  
SMMX3000-GR Service man. for Regency MX3000... \$19.95  
B-4-GR 1.2 V AAA Ni-Cad batteries (set of four)..... \$9.95  
B-8-GR 1.2 V AA Ni-Cad batteries (set of eight)..... \$17.95  
FB-E-GR Frequency Directory for Eastern U.S.A..... \$14.95  
FB-W-GR Frequency Directory for Western U.S.A..... \$14.95  
ASD-GR Air Scan Directory..... \$14.95  
SRF-GR Survival Radio Frequency Directory..... \$14.95  
TSG-GR "Top Secret" Registry of U.S. Govt. Freq..... \$14.95  
TIC-GR Techniques for Intercepting Comm..... \$14.95  
RRF-GR Railroad frequency directory..... \$14.95  
CIE-GR Covert Intelligenct, Elect. Eavesdropping..... \$14.95  
A60-GR Magnet mount mobile scanner antenna..... \$35.95  
A70-GR Base station scanner antenna..... \$35.95  
USAMM-GR Mag mount VHF/UHF ant. w/12' cable..... \$39.95  
USAK-GR 3/4" hole mount VHF/UHF ant. w/17' cable..... \$35.95  
USATLM-GR Trunk lip mount VHF/UHF antenna..... \$35.95  
Add \$3.00 shipping for all accessories ordered at the same time.  
Add \$12.00 shipping per shortwave receiver.  
Add \$7.00 shipping per scanner and \$3.00 per antenna.

## BUY WITH CONFIDENCE

To get the fastest delivery from CE of any scanner, send or phone your order directly to our Scanner Distribution Center™. Michigan residents please add 4% sales tax or supply your tax I.D. number. Written purchase orders are accepted from approved government agencies and most well rated firms at a 10% surcharge for net 10 billing. All sales are subject to availability, acceptance and verification. All sales on accessories are final. Prices, terms and specifications are subject to change without notice. All prices are in U.S. dollars. Out of stock items will be placed on backorder automatically unless CE is instructed differently. A \$5.00 additional handling fee will be charged for all orders with a merchandise total under \$50.00. Shipments are F.O.B. Ann Arbor, Michigan. No COD's. Most products that we sell have a manufacturer's warranty. Free copies of warranties on these products are available prior to purchase by writing to CE. Non-certified checks require bank clearance. Not responsible for typographical errors.

Mail orders to: Communications Electronics™, Box 1045, Ann Arbor, Michigan 48106 U.S.A. Add \$7.00 per scanner for R.P.S./U.P.S. ground shipping and handling in the continental U.S.A. For Canada, Puerto Rico, Hawaii, Alaska, or APO/FPO delivery, shipping charges are three times continental U.S. rates. If you have a Discover, Visa or Master Card, you may call and place a credit card order. Order toll-free in the U.S. Dial 800-USA-SCAN. In Canada, order toll-free by calling 800-221-3475. WUI Telex anytime, dial 671-0155. If you are outside the U.S. or in Michigan dial 313-973-8888. Order today.

Scanner Distribution Center™ and CE logos are trademarks of Communications Electronics Inc.

† Bearcat is a registered trademark of Uniden Corporation.  
‡ Regency is a registered trademark of Regency Electronics Inc. AD #070286-GR

Copyright© 1986 Communications Electronics Inc.

For credit card orders call  
**1-800-USA-SCAN**

**COMMUNICATIONS ELECTRONICS INC.**

Consumer Products Division  
P.O. Box 1045 □ Ann Arbor, Michigan 48106-1045 U.S.A.  
Call 800-USA-SCAN or outside U.S.A. 313-973-8888  
CIRCLE 79 ON FREE INFORMATION CARD

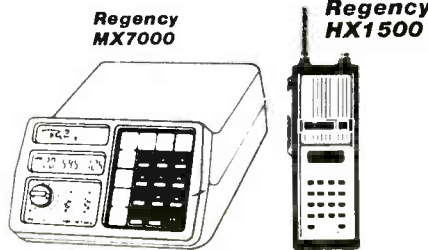
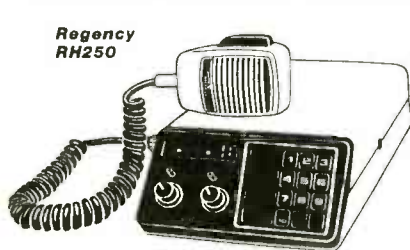

---

---

# WHAT'S NEWS

## Three firms team up to manufacture custom IC's

RCA and Sharp have signed a five-year agreement with Waferscale Inc., on manufacturing and technology of customer-specified, highly-integrated semiconductor components. The bulk of the development will be in Application-Specific Integrated Circuits, or ASIC's. Those are circuits tailored to perform a customer-specified set of functions.

A particularly promising ASIC design method, and the one on which the three companies will focus their joint efforts, is the "cell library" approach, in which a Computer-Aided Design (CAD) system modularly configures a custom circuit from pre-designed circuit function blocks called "cells."

As part of the agreement, RCA/Sharp Electronics has acquired about 7 percent of the stock of Waferscale and will be represented on its board of directors.

## Voice forward systems to take over in offices?

Voice store and forward (VSF) devices may change office procedures in the next few years, by permitting sender and receiver of a telephone message to communicate asynchronously, suggests international market-research firm Frost & Sullivan. In VSF, the sender's voice is digitized and stored on magnetic disk. When the receiver is ready to take the message, it is loaded into the machine's memory, restored to analog form and played back at the listener's phone.

Though one telephone answering machine is cheaper than one VSF, the VSF machine can support a whole office, serving hundreds of users at an average cost that's much lower than that of individual tape answering machines.

## FCC proposes 1605-1705-kHz guidelines

The FCC recommends that the United States submit two proposals to the upcoming International Telecommunications Union administrative radio conference in regard to the use of the expanded AM broadcast band (1605-1705 kHz) in the western hemisphere. Those proposals are that allotment planning be used and that station power be limited to 10 kW.

Allotment planning has several advantages over its alternative, assignment planning. In assignment planning each signatory country must submit its complete and detailed requirements, pinpointing each prospective station and stating power, antenna systems, and other characteristics for each. Under allotment planning, designated frequencies are made available for designated areas. Although the allotment of frequencies is based on the presumption of stations with presumed characteristics within presumed areas, the signatories are not bound to follow exact details. However, any departures from the plan must not increase interference to the services of other signatories.

As to the proposed power limit, the Commission believes that 10 kW provides for adequate service range, while making it possible to have enough stations to meet the requirements of the area.

## New polymer material simulates body tissue

Scientists of the National Bureau of Standards report the development of a new material that acts like living body tissues when exposed to the electromagnetic waves produced by certain medical instruments.

That substitute for living muscle marks a great step ahead for research by the Food and Drug Ad-

ministration. The FDA will use the new material to evaluate the heating patterns of devices used to generate the electromagnetic waves that heat body tissues for physical therapy, rewarm bodies after low-temperature surgery, and treat certain types of cancers.

The new substance will provide the FDA with a more stable research material, having a longer shelf life than currently available polymers. The FDA also will place the new NBS "phantom flesh" in test kits for the National Cancer Institute and others to use in checking the quality assurance of their medical devices.

## Asian TV sets and tubes are "dumped" on U.S. market

Jerry Pearlman, Zenith chairman and president, speaking at the annual shareholders meeting, condemned the "unfair and largely illegal" trade practices of Japanese, Korean, Taiwanese, and other Far-Eastern manufacturers of television sets.

Japanese TV manufacturers have been operating under a U.S. dumping finding since 1971. In 1984, Korean and Taiwanese manufacturers were also found guilty of dumping. To avoid dumping penalties, Far-Eastern producers have been shifting their exports from fully assembled TV sets to kits, including picture tubes and electronics. Those kits can be simply "snapped together" at the exporter's U.S. warehouses. Picture tubes are also being dumped directly at less than their fair-market price, Mr. Pearlman said.

Zenith asks that the government investigate those cases and take action against Far-Eastern manufacturers. The company is encouraged by bills seeking to stop unfair import practices; those bills have been initiated in both the House and Senate. **R-E**

# RAG

## ELECTRONICS, INC.

New and Used Electronic Test Equipment  
Sales • Service • Rental • Leasing

### HAMEG Oscilloscopes with Component Tester 2-year warranty

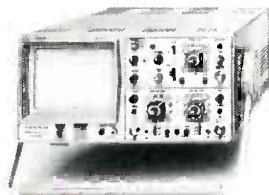

**HM 203-6** DC to 20MHz **\$489.00**

- Rectangular screen, internal graticule 8x10cm.
- Deflection: 5mV/cm to 20V/cm
- Timebase: 0.5us/cm to 0.2s/cm X-Magnification x 10
- Component Tester  
Test voltage: max. 8.5Vrms (open circuit)  
Test current: max. 24mA rms (shorted)



**HM 204-2** DC to 20MHz **\$629.00**

- Component Tester
- Deflection: 5mV/cm to 20V/cm Y-Magnification x 5
- Timebase: 0.1 us/cm to 0.5s/cm X-Magnification x 10
- Sweep delay: 100 ns to 0.1 s.
- Calibrator: square-wave generator, ≈1 kHz/1MHz switchable, risetime<5ns. for probe compensation, output voltages: 0.2V and 2V ± 1%.



**HM 605** DC to 60 MHz **\$899.00**

- Component Tester
- Deflection: 5mV/cm to 20V/cm Y-Magnification x 5
- Y-Output from Ch.I or Ch.II: ≈ 45 mV/cm into 50Ω.
- Timebase: 50ns/cm to 1 s/cm X-Magnification x 10
- Sweep delay: 100ns to 0.1s.



**HM 205** **\$799.00**

Real-time - See 203-6 Specifications

#### Digital Storage

- Operating modes: Refresh and Single with Reset (incl. LED indication for Ready), Hold Ch.I, Hold Ch.II. 1024x8 bit for each chan. Sample rate: max. 100kHz. Resolution: vertical 28 pts/cm, horiz. 100 pts/cm.
- Option: Interface for plotter.
- Component Tester

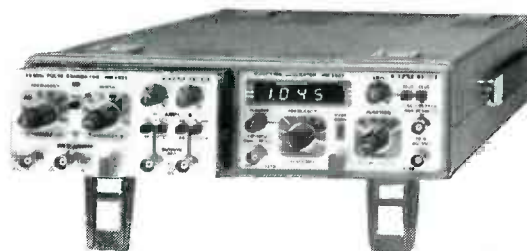

Modular System 8000

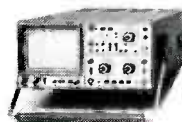

**HM 208** **\$2,380.00**

**HM 208-1** **\$2,860.00**

(with IEEE Interface)

Real-time - See 203-6 Specifications

#### Digital Storage

- Operating modes: XY, Roll, Refresh, Single (LED ind.), Hold Ch.I, Hold Ch.II, Plot I and Plot II with read-out check on screen, backing storage, Dot Joining button. 2 x 1024 x 8bit for each ch. Sample rate: max. 20MHz. Resolution: vert. 28 pts/cm, horiz. 200 or 100 pts/cm.
- Plotter output: vertical 0.1V/cm, horizontal 0.1V/cm. Output impeded: 100Ω each. Penlift: TTL/CMOS compat. Output speed rate: 5-10-20/10-20-40 s/cm.
- Option: Lithium battery for memory backup.

#### ATTACHES TO ALL HAMEG SCOPES ON THIS PAGE!

HM 8001	2 BAY Mainframe	\$228.00
HM 8002	4 BAY Mainframe	call SOON
HM 8011-2	Digital Multimeter 4½ digits	298.00
HM 8014	Milli Ohm Meter	298.00
HM 8021-2	Counter, 0.1Hz-1GHz	324.00
HM 8027	Distortion Meter	248.00
HM 8030-2	Function Gen. 0.1Hz-1MHz	288.00
HM 8032	Sine Wave Gen. 20Hz-20MHz	288.00
HM 8035	Pulse Generator, 2Hz-20MHz	455.00
HM 8037	Low Dist. Sine Gen. 5Hz-50kHz	248.00
HM 8040	Triple Power Supply	278.00
HM 8045	Oscilloscope Calibrator	378.00

CIRCLE 126 ON FREE INFORMATION CARD  
CALL US TOLL FREE

**1-800-732-3457**

IN CALIFORNIA TOLL FREE

**1-800-272-4225**

- Master Charge
- VISA ■ COD
- Money Order
- Check



ADD FOR SHIPPING AND INSURANCE

\$0 to \$250.00	\$4.50
\$251.00 to 500.00	\$6.50
\$501.00 to \$750.00	\$8.50
\$751.00 to \$1000.	\$12.50
over \$1000.00	\$15.00/1000

Prices subject to change without notice.

RAG ELECTRONICS, INC. / 21418 Parthenia Street / Canoga Park, CA 91304 / 1-818-998-6500

---

---

# VIDEO NEWS



**DAVID LACHENBRUCH**  
CONTRIBUTING EDITOR

● **Universal remote control.** Recently, one of the big features in many home-entertainment lines has been the unified remote-control, a unit that is capable of operating both a TV and a VCR—assuming both are made by the same manufacturer. The rub is that most people own TV sets and VCR's made by different manufacturers. GE introduced one solution last year when it marketed its programmable remote. That unit lets you operate several different pieces of equipment using just a single remote control; the GE remote "learns" the code used by your different infra-red remote control systems in just a few simple steps.

Now North American Philips has introduced a "universal remote" as standard equipment with most remote-control TV sets in its Magnavox, Sylvania, and Philco lines. That remote is pre-programmed with infrared codes for 29 different brands of VCR's (in addition to the brand of TV set with which it is sold). The user merely aims the remote at his VCR, simultaneously presses two buttons, and the remote-control unit starts to sequence through all of its built-in program codes. When it finds the right one and the VCR starts to change channels, the user merely releases the two buttons, and from then on the remote will control the VCR as well as the TV set. A more deluxe unit is also pre-programmed to operate with 15 different brands of remote-control cable-TV converters.

● **And Philips makes four.** Speaking of North American Philips, the illustrious worldwide Philips brandname will soon appear on some consumer electronics products in the U.S. Beginning in 1987, the company will affix that name to a new line of audiophile and videophile products, giving the company a fourth trade-name here and finally giving the Philips name visibility in the U.S. (Faithful audio fans will recall the Philips name was used on turntables and loudspeakers here several years ago.) In the early days of radio, the Philips name was kept out of this country because of the possibility that it

would infringe on the name Philco. Now North American Philips owns the Philco trade name.

● **Big, bigger, biggest.** That sequence, applied to color picture tubes, might refer to 27, 35, and 40 inches. The 35-inch tube was recently introduced by Mitsubishi and is featured in a \$3,300 color set. So encouraged has Mitsubishi become with the idea of large direct-view picture tubes that it plans to introduce a 40-inch color monitor-receiver priced at \$9,000 to \$12,000 in Japan.

Although the big tube is new, the idea isn't. In the 1950's, the late TV-pioneer Dr. Allen B. DuMont proposed theater-sized direct-view monochrome tubes with diagonal measures approaching 10 or 11 feet.

● **Flat is flat.** There has been a lot of discussion in the last couple of years about "flat faced" picture tubes. Toshiba's former Flat Square Tube was recently renamed Flattest Square Tube. Now it will have to be renamed something else, because Zenith has introduced a color picture tube whose face is flat, period. So flat, in fact, that a sheet of window glass can be used for implosion protection. The secret of Zenith's new FTM tube is a Flat Tension Mask, which gives the tube its name. Instead of the normal domed shadow mask, the new tube has a thin foil shadow mask stretched flat, held under tension and sealed into the glass just behind the faceplate. Unlike conventional shadow masks which can expand and shift with heat, Zenith says the stretched mask doesn't move at all under most conditions, even at brightness that can cause distortion or wrong colors in conventional tubes.

Also, because the face is flat, it inherently is less reflective. Thus an image on the tube appears similar to a slide viewed on a screen or in a viewer. The first FTM tube, available by the middle of 1987, will be a 14-inch ultra-high-resolution computer display, but future versions are expected for TV and all other CRT applications. Zenith says its cost involves a "very modest" premium over conventional tubes. **R-E**



**CALL TOLL FREE**

CALIFORNIA 800-772-1519  
OTHER STATES 800-854-1519

IN SAN DIEGO CALL  
619-560-9676

**FREE CATALOG!**



**PROBE MASTER**

**YOUR SINGLE SOURCE FOR PROBES AND ACCESSORIES**

**IT'S SOFT, IT BENDS, IT FEELS GOOD**

- ★ SOFT, COMFORTABLE HAND GRIPS
- ★ CONFORMS TO THE SHAPE OF YOUR HAND
- ★ NO MORE CALLOUSES, EASY ON THE FINGERS
- ★ LEADS LAST LONGER ★ RUBBER COVERED WIRE
- ★ SHARP POINTS, NICKEL PLATED STAINLESS STEEL
- ★ SCREW ON ACCESSORIES ★ 10 AMPS MAXIMUM CURRENT
- ★ 11 PIECE KIT (INCLUDING STORAGE POUCH) ★ MADE IN U.S.A.

**NEW 1987 "THE SOFTIE"™**



**\$16**  
(KIT PRICE)

REPLACEMENTS FOR FLUKE, SIMPSON, BECKMAN, ETC.

**CALL NOW!**  
FOR INTRODUCTORY  
**10% DISCOUNT**

**NEW 1987**

**SWITCHABLE SCOPE PROBE KIT**



CALL US  
FOR 1X, 10X, 100X  
OTHER MODELS

**MONEY BACK GUARANTEE**

**IMMEDIATE DELIVERY**  
CALL FOR NEAREST DISTRIBUTOR

MODEL  
**6101K 150 MHz \$49**  
**6102K 275 MHz \$59**  
(INCLUDES POUCH & 14 ACCESSORIES)

- REPAIRABLE SPRUNG HOOK
- INPUT CAPACITANCE, 11.5 PFD.
- SAFETY FINGER GUARD
- REPLACEABLE TIP
- SNAP ON ROTATING GROUND



**PROBE MASTER** 4898 RONSON CT.  
SAN DIEGO, CA 92111

CIRCLE 96 ON FREE INFORMATION CARD

[www.americanradiohistory.com](http://www.americanradiohistory.com)

**NEW**

**Only NRI gives you a 27" high-resolution stereo color TV you build to prepare you for today's video servicing careers.**



**Become one of America's most sought-after technicians . . . put your talents and spare time to work for you in the "explosive-growth" world of home entertainment electronics.**

Train in state-of-the-art video/audio servicing and become a fully qualified service professional the uniquely successful NRI way. It's hands-on training, at home . . . designed around the latest electronic equipment you build and keep as part of your training. You start from scratch and "discover by doing." You conduct key experiments . . . perform vital tests . . . build your own systems . . . and do it all at the pace that suits you best.

There's no stopping the incredible boom in consumer electronics. Soaring sales, new and improved video products, entirely new technologies have opened up new opportunities for the trained technician as never before.

Now at \$26 billion in annual sales, the consumer electronics industry is creating a whole new servicing, installation, and repair market. This year, TV sales alone are expected to hit 16.2 million units. Every day, sales of home



VCRs, a product barely conceived of 10 years ago, reach 20,000 units. Every day!

And the revolution has spread to the business sector as tens of thousands of companies are purchasing expensive high-tech video equipment used for employee training, data storage, even video conferencing.

## The Video Revolution Is Just Starting

Already, disc players can handle audio CDs and laser video discs. And now there are machines that will accommodate laser computer disks as well. Camcorders are becoming smaller, lighter, and more versatile . . . 8 mm video equipment produces high-resolution pictures and digital audio. By 1990 our TVs will become interactive computer terminals, giving us entertainment, information, and communications in one sophisticated video/computer/audio system.

## Join the Future or Be Left Behind

Can you see the opportunity? The servicing and repair market that's there already . . . and the enormous future need created by the millions upon millions of electronic devices yet to come? If you're looking for a high-potential career . . . if you'd like to get started in a field that's still wide open for the independent businessperson . . . even if you'd like to find a way to make extra money part-time, look into NRI at-home training now.

## Start Right and There'll Be No Stopping You!

NRI training in video/audio servicing is the perfect way for you to profit from the new explosive growth in consumer electronics. You study at home in your spare time at your own pace. No classroom pressures, no night school grind.

Even if you've never had electronics training, NRI prepares you properly with a thorough grounding in the fundamentals . . . a foundation that you build on to achieve advanced electronics skills. With this kind of understanding and practical bench experience built into NRI's exclusive training methods, you're on your way to take advantage of the new opportunities opening up every day.

## Totally Integrated Hands-On Training

Since NRI training is built around "learn by doing," right from the start you conduct important experiments and tests with your professional digital multimeter. You assemble the remarkable NRI Discovery Lab and perform a complete range of demonstrations and experiments in the process.

## Hands-On Training As You Build a 27" Stereo TV

In just hours you assemble an exceptional state-of-the-art TV receiver using easy to follow, step-by-step instructions. During this assembly process, you learn to identify and work with components and circuits used in actual commercial circuitry. Then through tests, adjustments, and experiments you quickly master professional troubleshooting and bench techniques.

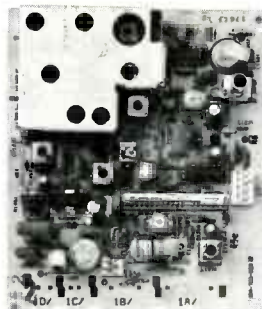

NRI's commitment to you goes beyond providing you with equipment appropriate to the latest technology. Of equal importance is our dedication to training techniques that let you master TV, video and audio troubleshooting and repair quickly and easily. Best of all, we ensure that in the learning process you acquire the very skills that will make you a professional service technician on the job.

NRI has purposely designed your training around equipment that has the same high-tech circuitry you'll encounter in commercial equipment. That means your training is real-world training. And *that's* unique.

## Inside Your TV

This new state-of-the-art Heath/Zenith 27" TV included with your training has all the features that allow you to set up *today* your complete home video center of the future. Flat screen, square corners, and a black matrix to produce dark, rich colors. Cable-compatible tuning, built-in stereo decoder to give you superb reproduction of stereo TV broadcasts . . . even a powerful remote control center that gives you total command of video and audio operating modes.

## Your NRI Training Has Another Special Element

Also built into your training is the enormous experience of NRI development specialists and instructors. Their long-proven training skills and enthusiasm come to you on a one-to-one basis. Available for consultation and help whenever you need it, your instructors ensure your success both during your course and after graduation.

## Step Into the Future Today

The richest reward you gain from your NRI video/audio training is a firm grip on the future. Your knowledge and know-how provide you with the soundest possible foundation for keeping up with the rapidly evolving, highly innovative video industry.

## Send For Free Catalog

Now is the time to act. Send the post-paid card to us today. You'll receive our 100-page catalog free. It's filled with all the facts you'll want to know about our training methods with full details on the equipment you'll use and keep as part of your hands-on training. You'll see how our more than 70 years of experience in uniquely successful at-home career training makes us the leading technical school today. (If someone has already used the card, write to us at the address below.)

**NRI** School of Electronics  
McGraw-Hill Continuing  
Education Center  
3939 Wisconsin Avenue, NW  
Washington, DC 20016



# ASK R-E

WRITE TO:

ASK R-E  
Radio-Electronics  
500-B Bi-County Blvd.  
Farmingdale, NY 11735

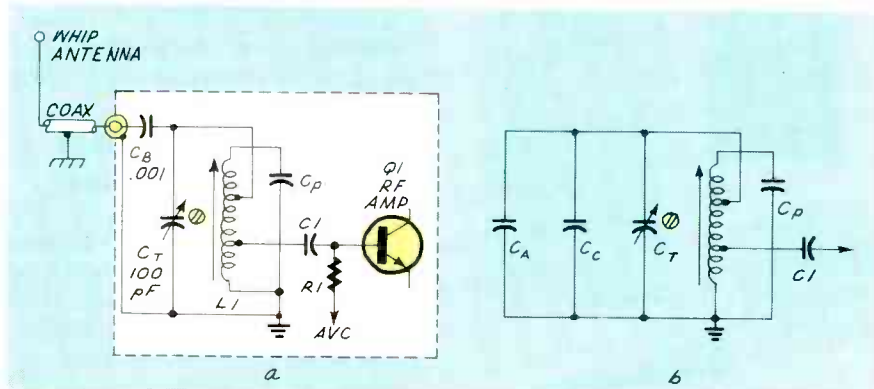

FIG. 1

## TRIMMING AM AUTO RADIO

Recently, I replaced the AM radio in my car with an AM/FM stereo model and installed a new antenna designed for AM/FM operation. FM performance is fine, but AM reception is miserable and doesn't compare with that of the set it replaced. Sensitivity is low, selectivity is poor, and there is a great deal of cross-talk from co-channel and adjacent-channel stations. What's wrong? Is there a defect in the AM section of the radio, or is the trouble in the installation?—R. U. P., Long Beach, CA

Figure 1-a shows a typical automotive AM antenna input circuit. A small padder capacitor,  $C_P$ , is connected across the coil, which is permeability tuned. That capacitor, along with stray circuit capacitance, ensures high selectivity.

The highest frequency is tuned when the slug (the powdered-iron or ferrite core) is out of the coil; tuned frequency decreases as the core moves into the coil. The inductance of the coil is chosen so that the coil can be tuned to the highest frequency (1550 or 1600 kHz) by adjusting a trimmer.

The antenna is connected to a tap on the high (i. e., high-imped-

ance) end of the antenna coil through a shielded cable and a DC-blocking capacitor,  $C_B$ . A trimmer capacitor,  $C_T$ , is connected between the tap and ground.

Figure 1-b shows how various stray capacitances must be considered part of the circuit. Capacitor  $C_A$  represents the capacitance between the antenna and the body of the car, and  $C_C$  is the capacitance of the shielded connecting cable. Blocking capacitor  $C_B$  is not shown because it is effectively in series with  $C_T$  and, because it is much larger than  $C_A$  and  $C_C$ , can be ignored. Note that  $C_A$  and  $C_C$  affect the resonant frequency of the circuit; their effect is most pronounced at high frequencies.

When a new antenna is installed (or the radio is replaced), trimmer  $C_T$  must be adjusted. Use a service manual, the manufacturer's instructions, or, lacking those, follow this procedure:

1. Extend the antenna to full length.
2. Tune in a weak station between 1200 and 1500 kHz.
3. Adjust the volume control for maximum output.
4. Locate  $C_T$ . You can usually adjust it through a hole in the case

near the antenna's input jack.

5. Use a non-conductive alignment tool and adjust the trimmer for maximum output, as heard through the speaker. If you can't tune in a signal at the high-frequency end of the band, adjust the trimmer for maximum background noise. Now, assuming your radio has no other problems, reception should be drastically improved.

Here's a cheap-and-dirty trick you can use to check alignment. Tune in a weak high-end station and turn up the volume. While standing on dry ground, grasp the antenna near the tip. If the volume drops, alignment of the antenna-circuit is probably OK. The reason is that you are detuning the circuit by adding capacitance between the antenna and the car body.

## FLUORESCENT LIGHTS

How does a fluorescent lamp work? I know that it usually needs a ballast and a starter, but I can't find any information on its principles of operation.—D. A.

A good article on the subject appeared in the March 1976 issue of *Popular Mechanics*. The article is called "What You Should Know About Fluorescent Lamps;" it appears beginning on page 120 of that issue. Your local library may have that issue on file, or it may be able to borrow a copy for you from another library.

Another good source of information is the booklet *Fluorescent Lamps* (TP-111R, Dec. 1978), published by General Electric Company, Lamp Products Division. You may be able to get a copy of that booklet from General Electric, Lighting Business Group, Nela Park, Cleveland, OH 44112. R-E

# PERFORMANCE

## THAT IS OUT OF THIS WORLD...



**\$389<sup>00</sup>**

**MODEL 2000 20MHz  
DUAL TRACE**

**\$549<sup>00</sup>**

**MODEL 3500 35MHz  
DUAL TRACE DELAYED SWEEP**

## ...AT A DOWN TO EARTH PRICE

At last! Truly affordable test equipment with no compromise in design, and features you would expect to find only on oscilloscopes costing hundreds of dollars more! JDR Instruments presents two, new, high-performance models backed by a two year warranty and technical support which is only a phone call away. Perfect for the technician or advanced hobbyist, both models feature Dual Trace capability and a variety of operating and triggering modes, including CH-B Subtract and X-Y operation.

MODEL 2000 has a 20 MHz bandwidth and 20 calibrated sweeps ranging from .2s to .2 $\mu$ s. A convenient built-in component tester provides additional diagnostic power.

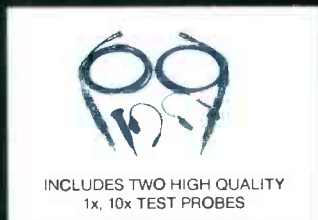

INCLUDES TWO HIGH QUALITY  
1x, 10x TEST PROBES

CIRCLE 59 ON FREE INFORMATION CARD

MODEL 3500 features a 35 MHz bandwidth and exceptional 1mV/DIV sensitivity. Delayed sweep and variable holdoff allow stable viewing of complex waveforms.

**ORDER TOLL FREE**  
**800-538-5000**  
**800-662-6279 (CA)**



### JDR INSTRUMENTS

1224 South Bascom Avenue  
San Jose, California 95128 (408) 995-5430

# LETTERS

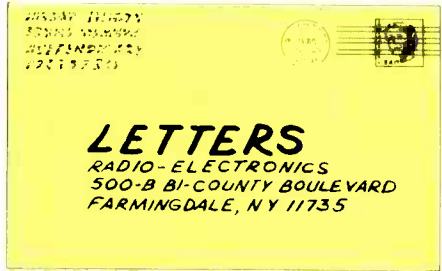

## SPEED-GUN CALIBRATOR

The address of the parts supplier for the speed-gun calibrator was listed incorrectly in the Parts List ("Build This Radar Speed-Gun Calibrator," *Radio-Electronics*, August 1986). The correct address is: Microwave Control, 1701 Broadway, Suite 263, Vancouver WA 98663. Microwave Control can be reached by telephone at 1-206-693-6843.



## LARGE TESLA COILS

First, I would like to say that I enjoy *Radio-Electronics*. It has something for everybody, and your articles are both informative

and interesting. I especially like Jack Darr's "Service Clinic" and the "Antique Radios" department.

Now I have a couple of questions. I am interested in large Tesla

coils—the RF oscillator type, not especially the spark gap. Could you feature an article on that subject, or could you tell me a source of article reprints or construction plans in that area?

Also, I think that other readers also might like to see schematics of antique radios presented in the "Antique Radio" department. That should help us to restore old sets. NOLAN F. SMITH  
*Fayetteville, NC*

## THE REGENCY MX-7000

I have been the proud owner of a Regency MX-7000 for quite some time now, and want to expand on the review it received in the May 1986 *Radio-Electronics*. There are several points that require correction and also a very important aspect of that unit that was not mentioned.

The MX-7000 was somewhat underestimated by your review, even though what was described would be enough to put it at the top of the list. For instance, the top-end frequency coverage is specified to 1.2 GHz, not just 1.1, and actually the processor will allow it to be programmed up to 1.3 GHz. No doubt, the performance at 1.3 GHz is not great, but it should be interesting to the amateur radio community, which is seeing an increase in FM repeater activity in that range. In addition, the unit has selectable delay and search-frequency increments.

I think that the search-frequency increment selection was misquoted as selectable bandwidth, which it is not. It is, however, very important to be able to search in 5, 12.5, or 25 kHz steps, depending on the service of primary interest. As for variable bandwidth, the unit operates in three different modes, each of which has a bandwidth appropriate for that mode.

## Card Size Digital Multimeter



### TESTON'S CHECKMAN MINI

fits any shirt pocket. Carry it with you at all times to test and measure AC/DC volts, ohms, and even do diode checks. **Self-contained in a vinyl case, with probes attached, this compact 3½ digit multimeter folds to approx. 4.5"H x 3"W x 0.5"D and weighs only 3 oz.** Always ready for action, the high quality CHECKMAN MINI offers built-in autoranging, easy-to-read 0.4" high LCD, continuity/diode testing, and low cost.

To order, for shipment within the USA, send check or money order for \$29.95 plus \$1.50 for handling and shipping or call 203/967-4441. **FULL ONE YEAR WARRANTY.**



**SIBER HEGNER NORTH AMERICA INC.**  
5 Landmark Square, Stamford, CT 06901  
Tel: 203/967-4441 Telex: 279653 SANDH UR

CIRCLE 199 ON FREE INFORMATION CARD

# Buy a Hitachi Scope from Joseph's... Get FREE DELIVERY\* and a FREE DMM!

\*To UPS-shippable destinations only



V1100A 100MHz  
Quad Channel/8 Trace

## Pocket Calculator-Size DMM Yours FREE with Each Hitachi Scope



- 3 1/2-Digit LCD ■ Auto-ranging
- Continuity Beeper
- AC/DC Volts ■ Resistance
- Test Leads, Battery ■ Case
- 4 1/4" H x 2 1/4" W x 0.4" D

### V1100A 100 MHz Quad Channel/8 Trace

Reg. \$2490<sup>00</sup> Price **Joseph's \$2235<sup>00</sup>** Free Delivery!  
Free DMM!

- CRT Readout ■ Built-in Computer ■ Cursors
- Built-in DVM and Frequency Counter
- Digital Measurement ■ Delayed Sweep
- 6" CRT ■ 18KV Acceleration
- 1 mV/Division Sensitivity
- 2 ns/Div. Max. Sweep ■ High 2% Accuracy
- Probes, Dustcover included

### V1050F 100 MHz 4 Channel w/ Delayed Sweep

Reg. \$1595<sup>00</sup> **Joseph's \$1175<sup>00</sup>** Free Delivery!  
Free DMM!

- 6" CRT ■ Alt. Time Base ■ 5 mV/Div Sensitivity
- 2% Accuracy ■ Full TV Triggering
- Probes, Dustcover included

### V650F 60 MHz Triple Trace w/ Delayed Sweep

Reg. \$1195<sup>00</sup> **Joseph's \$885<sup>00</sup>** Free Delivery!  
Free DMM!

- Our Best Seller! ■ 6" CRT ■ Auto-Focus
- 1 mV/Div Sensitivity ■ 3% Accuracy
- Trigger View ■ Probes, Dustcover included

### V423 40 MHz Compact Dual Trace w/ Delayed Sweep

Reg. \$995<sup>00</sup> **Joseph's \$675<sup>00</sup>** Free Delivery!  
Free DMM!

- 6" CRT ■ 1 mV/Div ■ DC Offset ■ 3% Accuracy
- 20 ns/Div Sweep ■ Only 12.2 x 5.1 x 14.6", 15 1/2 lbs.
- Probes included

### V222 20 MHz Dual Trace w/DC Offset

Reg. \$715<sup>00</sup> **Joseph's \$535<sup>00</sup>** Free Delivery!  
Free DMM!

- 6" CRT ■ Vert. Trigger Mode ■ 1 mV/Div
- 100 ns/Div Sweep w/ 10x mag. ■ 14.3 lbs.

### V212 20 MHz Dual Trace Scope

Reg. \$615<sup>00</sup> **Joseph's \$475<sup>00</sup>** Free Delivery!  
Free DMM!

- Same as V222 above, less DC Offset



Write for  
**FREE Catalog**  
116 pages of  
tremendous  
discount prices  
on 25 leading  
instrumentation  
lines.  
Write today!

Famous **HITACHI** Scopes at  
Joseph's Low Discount Prices!

**Hurry! Quantities  
limited at sale prices!**

# Joseph Electronics

8330 N. Milwaukee Ave Niles, IL 60648

VISA, MASTERCARD & DISCOVER  
Phone Orders Welcome

Call **1-800-323-5925**

In Illinois: 312-297-4200

# SHOCK ABSORBER.



## RCA's Power Safe surge suppressors absorb voltage surges before your customers' electronics get damaged.

Now you can help your customers protect their expensive electronic equipment from sudden shock with two new surge suppressors from RCA.

The Power Safe (SK406) protects TVs, computers, microwaves and more by absorbing transient voltage surges resulting from nearby lightning strikes, load switching and other causes before the surge hits the equipment. Handsomely designed and easy to install, this handy six-outlet strip simply plugs into any grounded wall outlet.

The Power Safe Plus (SKF406) protects every way the Power Safe does, plus it filters out electronic noise interference. The suppressor's high-frequency bi-directional filter senses, absorbs, and dissipates noise interference before it can reach the equipment.

Together, they have the potential to become powerful profit builders for you.

To learn more about this shock-absorbing team, see your RCA Distributor. Or contact RCA Distributor and Special Products Division, Deptford, NJ 08096-2088.

**RCA** Distributor and  
Special Products Division

CIRCLE 201 ON FREE INFORMATION CARD



Of some interest is the ability to listen to broadcast FM transmissions between 88 and 108 MHz. I have a feeling that, for some prospective buyers, that single fact may be enough to allow some strain on the budget. Needless to say, the *MX-7000* is quite a radio and is worthy of consideration by the serious user.

A couple of quick points: The article noted that the BNC connector on the back of the *MX-7000* is more secure than the connectors normally found on monitor radios. That's true, but there's an even more significant reason for its use. The Motorola-type connectors (and, for that matter, the so-called UHF connectors) become inadequate at higher frequencies. A BNC connector is what is called a "constant impedance" connector. That means that it exhibits the same electrical properties as the transmission line, and results in a more efficient signal transfer. I can vouch for that through experience with the 450-MHz ham band, where using a UHF-type barrel connector between two cables will do serious damage to your SWR. When operating at near microwave frequencies (0.8 to 1.3 GHz) the effect would be very substantial.

Second point: In looking at the frequencies that are stored in the 20 memory channels, it appears that they are more likely for testing and adjustment of the unit. Trying to assume which frequencies—of over 200,000 possibilities—are going to be popular may be a bit presumptuous.

I regret to say that one quality of the *MX-7000* is not so admirable: the sluggish way in which it gets around to doing things. No doubt the microprocessor (mounted on the back of the front panel) is very busy, but the speed at which it operates is responsible for the lack of crisp response that one should get from the keypad and for the somewhat lethargic scanning speed. Fortunately, the manufacturer decided not to use a crystal-based clock, and that gives the user an opportunity to find out just how fast this thing really can go. The resistor marked R6 on the back of the front-panel assembly is part of an R/C time-constant circuit which

sets the processor's clock speed; its value can be changed easily. I found a value of 39K suitable for my unit.

Unfortunately, it has been a while since I changed that part, and I'm not sure of its original value—but there is a substantial increase in speed. To make installation of the new resistor easier, I didn't bother to desolder the leads of the old resistor; I simply clipped off the old one near the board and tacked the new one on.

The performance increase using the new value effectively eliminates the *MX-7000's* single limitation. Most likely, the manufacturer was trying to be conservative in selecting the processor speed to ensure reliable operation throughout the temperature specification. In reality, most users would not subject it to such extremes, and in any case would be unable to vary the value of R6 should erratic operation occur. As for my unit, it has been in our van through all sorts of environmental conditions and hasn't burped once.

Final note: While the price may seem a bit high, there are outlets who sell the *MX-7000* at a very competitive price. As an example one of your advertisers sells that unit for under \$400.00. At that price, considering the advanced functionality, and with the change in clock speed, the Regency *MX-7000* graduates with high honors.

CHARLES P. SCOTT  
Mt. Sterling, KY

### VOLTAGE COMPARATORS

I have just read the article on the care and feeding of voltage comparators in the June, 1986 *Radio-Electronics*, and am impressed with the range of circuits and applications available. However, I find one of the circuits a bit less than impressive, due to two rather well-hidden flaws that will prevent its being useful for its intended purpose.

The circuit in question is the one shown in Fig. 16. That circuit is intended to be a "micro-power" circuit by virtue of applying power to the sensing and control circuit for a very small fraction of the time. The first problem with that ap-

## Scan and record temperatures from freezing to scorching.



The new Fluke 52 goes to great extremes to outperform any other handheld thermometer.

At the touch of a button, it sequentially scans the readouts of two temperature inputs and their difference. Or records the minimum and maximum from any one of these three channels for up to 1,200 hours.

You can measure extreme temperatures with 1/10th of a degree resolution, using standard K or J type thermocouples probes.

Prices for the Fluke 50 Series are surprisingly low... starting at just \$119 for the single-input Fluke 51. Order yours today.

For the name of your local supplier and a free brochure call toll-free 1-800-227-3800, Ext. 229.

FROM THE WORLD LEADER IN HANDHELD TEST INSTRUMENTS.

### FLUKE 51/52 THERMOMETERS

Measurement range:
K-type: -200°C to +1370°C (-328°F to +2498°F)
J-type: -200°C to +760°C (-328°F to +1400°F)
Accuracy:
K-type is ±(0.1% of reading + 0.2°C or 1.3°F)
J-type is ±(0.1% of reading + 0.8°C or 1.4°F)
°C or °F Selectable • Hold Mode
Scan, Differential and Min/Max Recording Modes (52 only)
Standard mini-connector input
1200 hour 9V battery life • 3-year warranty
General-purpose K-type bead probe included (two with 52)

© 1986 Fluke



CIRCLE 121 ON FREE INFORMATION CARD 17

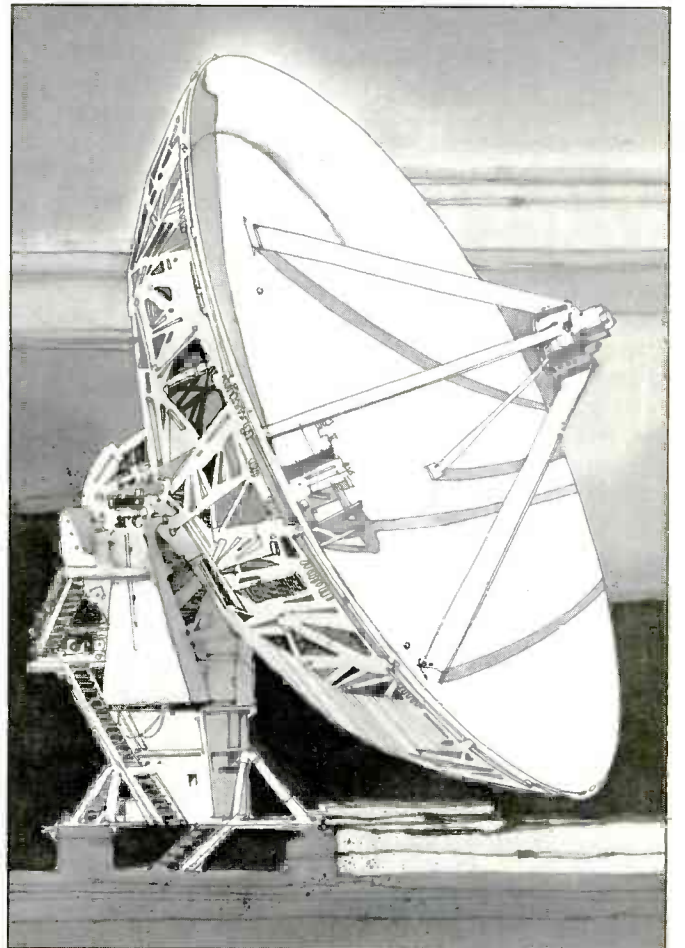
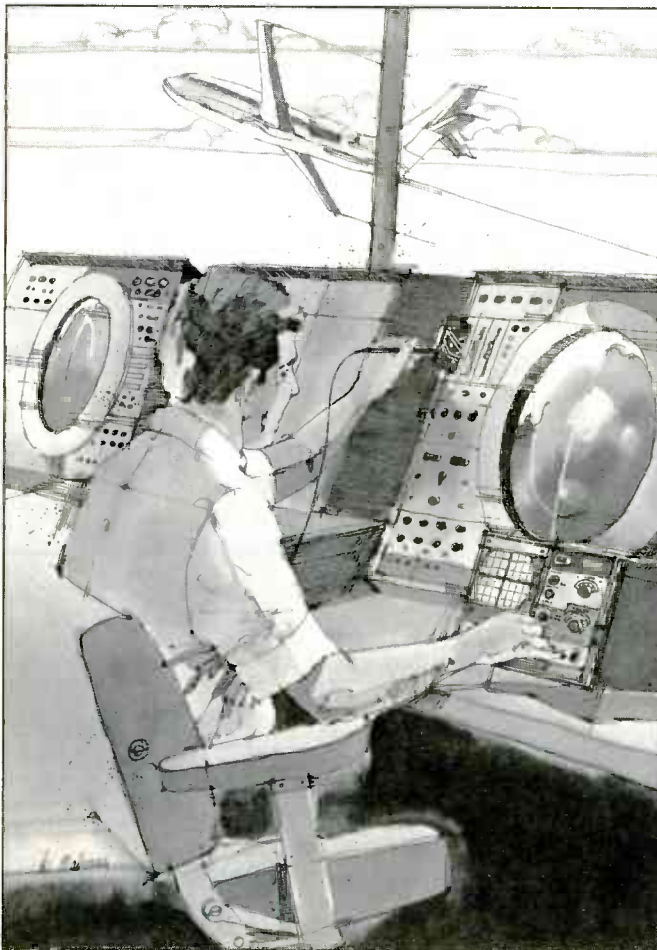
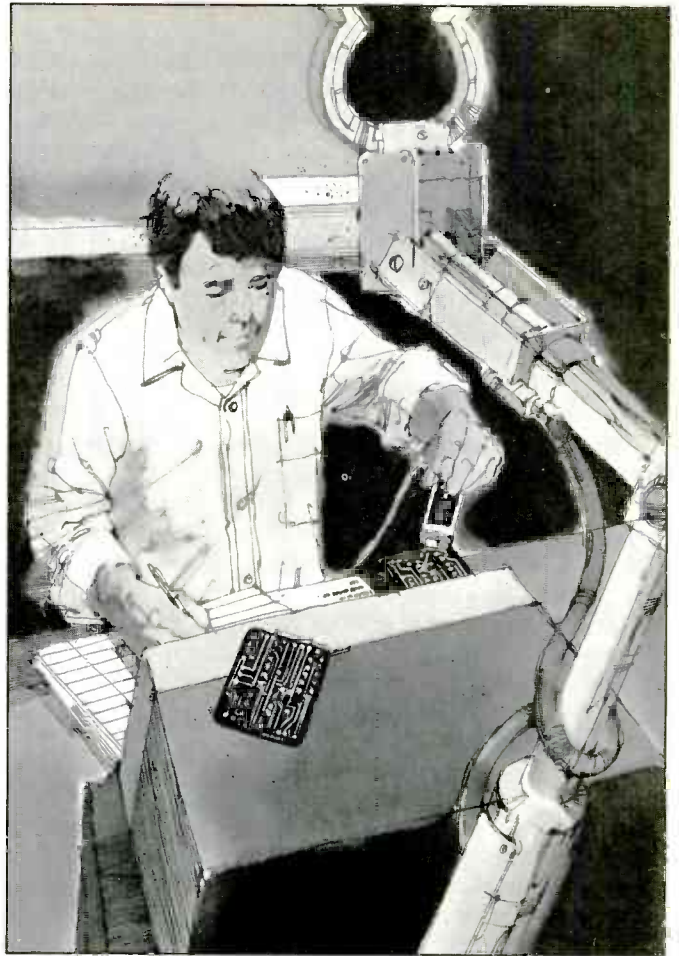

# CIE MAKES THE WORLD OF ELECTRONICS YOURS.

**T**oday's world is the world of electronics. To be part of it, you need the right kind of training, the kind you get from Cleveland Institute of Electronics, the kind that can take you to a fast growing career in business, aerospace, medicine, science, government, communications, and more.

## **Specialized training.**

You learn best from a specialist, and that's CIE. We're the leader in teaching electronics through independent study, we teach only electronics and we've been doing it for over 50 years. You can put that experience to work for you just like more than 25,000 CIE students are currently doing all around the world.

## **Practical training.**

You learn best with practical training, so CIE's Auto-Programmed® lessons are designed to take you step-by-step, principle-by-principle. You also get valuable hands-on experience at every stage with sophisticated electronics tools CIE-designed for teaching. Our 4K RAM Microprocessor Training Laboratory, for example, trains you to work with a broad range of computers in a way that working with a single, stock computer simply can't.

## **Personalized training.**

You learn best with flexible training, so we let you choose from a broad range of courses. You start

with what you know, a little or a lot, and you go wherever you want, as far as you want. With CIE, you can even earn your Associate in Applied Science Degree in Electronics Engineering Technology. Of course, you set your own pace, and, if you ever have questions or problems, our instructors are only a toll-free phone call away.

## **The first step is yours.**

To find out more, mail in the coupon below. Or, if you prefer, call toll-free **1-800-321-2155 (in Ohio, 1-800-523-9109)**. We'll send a copy of CIE's school catalog and a complete package of enrollment information. For your convenience, we'll try to have a representative contact you to answer your questions.

## **CIE** Cleveland Institute of Electronics

1776 East 17th St., Cleveland, Ohio 44114

YES! I want to get started. Send me my CIE school catalog including details about the Associate Degree Program. I am most interested in:

- |  |   |
|--|---|
| <input type="checkbox"/> computer repair     | <input type="checkbox"/> television/high fidelity service |
| <input type="checkbox"/> telecommunications  | <input type="checkbox"/> medical electronics              |
| <input type="checkbox"/> robotics/automation | <input type="checkbox"/> broadcast engineering            |
| <input type="checkbox"/> other _____         |   |

Print Name \_\_\_\_\_

Address \_\_\_\_\_ Apt. \_\_\_\_\_

City \_\_\_\_\_ State \_\_\_\_\_ Zip \_\_\_\_\_

Age \_\_\_\_\_ Area Code/Phone No. \_\_\_\_\_

Check box for G.I. Bulletin on Educational Benefits

Veteran  Active Duty **MAIL TODAY!**

**OR CALL TOLL FREE**  
**1-800-321-2155**  
(In Ohio, 1-800-523-9109)

RE-44

proach is that the sample-pulse generator, which determines how long the main control-circuit is powered, must itself be powered continuously in order to work. That flaw, perhaps, is not so bad, since presumably the sample-pulse generator could be built out of CMOS components and draw minimal power.

A much worse difficulty arises from the fact that, when the controller determines that power must be applied to the load, the relay will draw considerable power, regardless of how low the drain of the control circuit is. Thus, the overall circuit is truly micropowered only if the load is never turned on! But in that case, who needs a control circuit?

HOWARD MARK  
Suffern, NY

### OOOOPS!

Several errors crept into the article, "Build This Little Leakage Checker," which appeared in the May 1986 issue. In the Parts List on page 56 and the schematic on page

57, C3 should be 0.0022  $\mu$ F, polyester. Resistor R22 in the schematic should be 249K; it is shown correctly in the Parts List. Switch S1-b is shown incorrectly in the schematic; it should complete the discharge path to ground as shown in the block diagram on page 56.

In the parts-placement diagram on page 58, capacitor C7, which is located between Q1 and R5, should be C2 (0.1  $\mu$ F). Near IC3, R15 should be R4 (270 ohms). And the locations of D11 and R14 are transposed, as are the locations of D12 and R13.

GARY McCLELLAN

### BI-POLAR POWER SUPPLY

Regarding the bi-polar power supply shown on page 9 of the May 1986 *Radio-Electronics*, I hope that N. J. S. did not build the supply and try to use it for his project. Two errors make the project unworkable. The center tap of T1 should go (only) to the junction of C1 and C2; that point is circuit ground. In addition, the junction of D1 and D2 should go (only) to the negative

side of C2. That is the negative nine-volt output of the circuit.

Rather than using individual 1N4001 diodes, a fullwave bridge rectifier, such as Radio-Shack catalog number 276-1151, could be used. It costs only pennies more, is rated 50PIV, 1.5 amps, and is small. The whole unit is built into one of Radio-Shack's plastic enclosures. The size of the case depends on the size of the transformer used. Output terminals are used for easy connection. It makes a nice, neat package when used in conjunction with 35-volt radial-type capacitors.

I hope that N. J. S. can use the corrected circuit to full advantage now.

WILLIAM N. BROOKS  
Henrietta, NY

### KIRLIAN PHOTOGRAPHS

The article, "How to Make Kirlian Photographs," which appeared in the May 1986 *Radio-Electronics*, has done a disservice to your readership and to science by  
*continued on page 87*

## NOISE REDUCTION FOR UNDER \$10.

MIXING CONSOLES  
SWITCHES  
MICROPHONE CONNECTORS  
SNAKE CABLES  
BATTERY CONTACTS



ALL PLUGS & JACKS (XLR, PHONE, PHONO, DIN, MIDI, ETC.)  
PATCHBAYS  
FADERS, POTS  
TERMINAL STRIPS  
SPEAKER TERMINALS

### CRAMOLIN®

Even the finest equipment in the world cannot guarantee noise-free operation. One "dirty" connection anywhere in the electrical path can cause unwanted noise or signal loss.

"MORE THAN A CONTACT CLEANER"

**CRAMOLIN®** is a fast-acting, anti-oxidizing lubricant that cleans and preserves all metal surfaces, including gold.

When applied to metal contacts and connectors, **CRAMOLIN®** removes resistive oxides as it forms a protective molecular layer that adheres to the metal surfaces and maintains maximum electrical conductivity.

**CRAMOLIN®** - USED BY THOSE WHO DEMAND THE BEST:

Bell & Howell	Hewlett Packard	MC(Sony)	Nakamichi
Capital Records	John Fluke Mfg.	Motorola	RCA
Dolby Laboratories	McIntosh Labs	NASA	Switchcraft

SINCE 1956

**CAIG LABORATORIES INC**

1175-O Industrial Ave., (P.O. Box J) - Escondido, CA 92025-0051 U.S.A. • (619) 743-7143

CIRCLE 182 ON FREE INFORMATION CARD

Call us FREE 1-800-626-6343  
or write for FREE Flyer.

## COPPER ELECTRONICS

4200 PRODUCE ROAD - LOUISVILLE, KY 40217

 <p><b>RAEBIT</b> VCR Multiplying System</p> <p>WATCH YOUR VCR FROM ANY TV IN THE HOUSE</p> <p>6 LOT 64.95 Retail 139.95 69.95</p>	 <p>WHISTLER Q2500 Superhet Quadradyne Radar Detector</p> <p>Retail 239.95 119.95</p>
<p>Snake Charmer</p> <p>Retail 119.95 59.95</p> <p>QUANTITY PRICING AVAILABLE</p> <ol style="list-style-type: none"> <li>1. FORWARD WATTAGE AND REFLECTED WATTAGE</li> <li>2. CALIBRATE FOR SWR (VSWR) STANDING WAVE</li> <li>3. POWER WATTAGE RANGE SETTING</li> <li>4. SEALED METER MOVEMENT</li> </ol>	 <p>uniden 800XLT AIR/POLICE/800 MHz SCANNING RADIO</p> <p>Retail 449.95 289.95</p>

**LOWEST PRICES IN THE COUNTRY!**

We have a national factory warranty service on many brands, and we service All CB, Amateur, and Commercial Equipment.

CIRCLE 125 ON FREE INFORMATION CARD



# EQUIPMENT REPORTS

## Soar Model 3430 DMM

*A 4½-digit meter with all the bells and whistles*

CIRCLE 9 ON FREE INFORMATION CARD



FOR MOST OF US, SELECTING A DMM boils down to a process of weighing which features we need or want against the price of the instrument. Often, we wind up doing without some of the features we would like because a DMM without some of the bells and whistles is better than no DMM at all.

But for a select few such compromises are not acceptable. The reason is not ego, but a genuine need for a full-featured, highly accurate unit for aligning or trou-

**WAVETEK®**

## Our 2 MHz Function Generator has an unlimited range.

Model 20 not only covers the .002 Hz to 2.1 MHz frequency range, it covers the world. With internal NiCad batteries,\* you can take Model 20 anywhere and get triggered, gated or continuous waveforms—sines, squares, and triangles up to 20 volts peak to peak. It recharges from wall transformer (included) or external source from 12 to 25 VDC or 10 to 18 VAC. Model 20 also has many of the features you would expect from the industry leader in function generators, including VCG input connector for external sweep or FM, step attenuator to -80dB, and a TTL pulse output. The price is just \$395. For a data sheet or to order, call or write Wavetek San Diego, P.O. Box 85265, 9045 Balboa Ave., San Diego, CA 92138. Phone (619) 279-2200; TWX (910) 335-2007. \*Batteries not included.

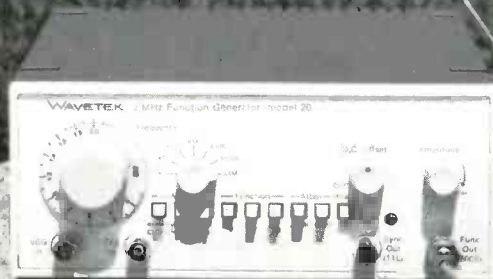

CIRCLE 194 FOR DEMO, CIRCLE 203 FOR LITERATURE

Simpson Electric Co.  
Introduces

# mercER

## The Ultimate in Low-Cost Test Equipment

At last! Here is your opportunity to take your pick from a new test equipment line that has all the features you need and more... and at a price that is unbelievably low.

**MODEL 9340**  
Pocket size, 3½-digit  
DMM with 20 megohm  
range and 10 megohm  
input resistance  
\$44<sup>00</sup>

**MODEL 9670**  
Digital capacitance  
tester covering 0.1 pF  
to 20,000 µF  
\$99<sup>00</sup>

**MODEL 9101**  
Compact VOM with 27  
ranges, including a  
100 megohm range  
\$29<sup>00</sup>

**MODEL 9301**  
3½-digit, hand-held  
DMM with 0.25%  
basic accuracy and  
2,000-hour battery life  
\$69<sup>00</sup>

**MODEL 9120**  
Analog VOM with 12 A  
DC range and output  
jack  
\$39<sup>00</sup>

**MODEL 9401**  
4½-digit, full function,  
hand-held DMM with  
.05% accuracy and  
data hold  
\$129<sup>00</sup>

**MODEL 9701**  
digi-clamp™ compact  
AC clamp-on volt-ohm-  
ammeter with data hold  
\$69<sup>00</sup>

**MODEL 9370**  
3½-digit autoranging  
DMM with a memory  
mode and 0.5% basic  
DC accuracy  
\$59<sup>00</sup>

# mercER

## ELECTRONICS

Division of Simpson Electric Company

859 Dundee Avenue, Elgin, IL 60120-3090  
(312) 697-2265 • Telex 72-2416

Mercer Electronics products reflect the design and quality standards established by Simpson Electric Company, an industry leader for over 50 years and known worldwide for its integrity and product excellence.

**In Stock... Available Now!** Stop in at your nearest distributor and see this new, complete line of Mercer test instruments. For the name of the MERCER distributor in your area, call (312) 697-2265, or send for our new line catalog.

CIRCLE 184 ON FREE INFORMATION CARD

# Check Digital IC's in-circuit Fast!

In the field or on the bench. B&K-PRECISION gives you the answers for TTL or CMOS



Model 550 (for TTL) \$395  
Model 552 (for CMOS) \$395

New B&K-PRECISION IC Comparator Testers/Logic Monitors put you on the fast track to digital troubleshooting. IC's are tested by comparison to a known good device, allowing you to test hundreds of types with one simple operation.

As logic monitors, they simultaneously indicate the logic states of up to 20 IC pins. No need to check pins singly with a logic probe.

Tests most 14 to 20 pin, 54 and 74 Series TTL (Model 550) or 4000 and 74C Series CMOS (Model 552) devices.

- Convenient one button testing
- Reverse polarity and overvoltage protection
- Uses power from equipment under test
- Memory stores short duration pulses and intermittent events
- Zero insertion force reference IC socket
- LED at each IC pin identifies where fault exists
- Includes 16 and 20 pin DIP clips
- Compact hand-held size

Available from stock at your local B&K-PRECISION distributor. For more information contact your distributor or:

**BK PRECISION**  
**DYNASCAN**  
**CORPORATION**

6460 West Cortland Street  
Chicago, Illinois 60635 • 312/889-9087

International Sales: 6460 W. Cortland St., Chicago, IL 60635  
Canadian Sales: Atlas Electronics, Ontario  
South and Central American Sales,  
Empire Exporters, Plainview, NY 11803

bleshooting sophisticated electronics gear. The Soar (1126 Cornell Ave., Cherry Hill, NJ 08002) model 3430 is a DMM designed with those users in mind. As a bonus, considering its features, the unit is a bargain; just a few years ago, it would easily have cost many times more.

## The model 3430

The model 3430 is a micro-processor-controlled, true rms-reading, 4½-digit DMM. It features 13 functions, and either AUTO or MANUAL ranging modes can be selected at the press of a button.

Unlike conventional DMM's that are 20,000-count units, the 3430 is a 25,000-count instrument. That allows for full 4½-digit resolution to the second decimal place. For example, 0.1-volt resolutions are possible on the 1000-volt DC range and 1-kilohm resolutions are possible on the 25-megohm range. At the other end of the scale, quantities as low as 10 µV and 0.01-ohms can be read.

Turning first to the standard

functions, the meter can measure AC and DC voltages over 5 ranges from 250-mV to 1000-volts (750-volts AC) full-scale. Accuracies on the DC ranges are specified as 0.05% ± 2 digits or better. On the AC ranges accuracy is 0.5% ± 2 dig-

Soar	3430									
OVERALL PRICE	1	2	3	4	5	6	7	8	9	10
EASE OF USE	1	2	3	4	5	6	7	8	9	10
INSTRUCTION MANUAL	1	2	3	4	5	6	7	8	9	10
PRICE/VALUE	1	2	3	4	5	6	7	8	9	10
	Poor		Fair			Good			Excellent	

its on all ranges except 750 volts, where it is 1% ± 2 digits.

Resistance is measured over 6 ranges from 250 ohms to 25 megohms full-scale. Accuracies are specified as 0.06% ± 2 digits ± 0.02 ohms on the 250-ohm range; 0.06% ± 2 digits on the 2500-, 25,000-, and 250,000-ohm

**NEW!**



**Weller®**  
**WTCPR \$77.50**

Safe for IC soldering. Closed loop, low-voltage circuit automatically controls output. 700 F 1/16" screwdriver tip provided. 600 F and 800 F tips available. Power unit has non-heat sinking iron holder, storage tray for extra tips and tip cleaning sponge with receptical. Send for free W.S. Jenks & Son electronics tool catalog for complete accessories.



**SEND NOW!**

## FREE CATALOG!

Over 100 pages. Wide selection of tool sets, test equipment, soldering and desoldering equipment, telecommunications and specialized electronics assembly tools.

**W.S. JENKS & Son**



2024 West Virginia Ave. NE  
Washington, D.C. 20002  
TOLL-FREE ORDER LINE: 1-800-638-6405

Please send the indicated material:

Weller WTCPR Soldering Station @ \$77.50  
 FREE W.S. Jenks & Son Catalog  
 Check/Money Order

MasterCard  Visa  Am. Exp.

Card No. \_\_\_\_\_ Exp. \_\_\_\_\_

Signature \_\_\_\_\_

Name \_\_\_\_\_

Address \_\_\_\_\_

City \_\_\_\_\_ State \_\_\_\_\_ Zip \_\_\_\_\_

VA residents add 4% tax; DC residents add 6% tax.



# COMB

Authorized Liquidator

ranges; 0.5% ± 2 digits on the 2500 kilohm range, and 2% ± 3 digits on the 25-megohm range.

The unit measures AC and DC current over two ranges, 250-mA and 10-amps full-scale. Accuracies are 0.25% ± 2 digits (250-mA DC), 1% ± 2 digits (10-amps DC), 0.75% ± 10 digits (250-mA AC), and 2% ± 10 digits (10-amps AC).

All ranges and functions, except the 10-amp range, are overload protected.

## Special functions

The 3430 also has a host of special functions. Those so-called bells-and-whistles quickly become indispensable when you've become accustomed to using them. Note that while many other meters have some of these functions, few have integrated as many as the 3430 in one unit.

CONTINUITY CHECK and DIODE TEST functions have now become commonplace. They even can be found on some low-end instruments. Both functions are, of course, present here. They work as you would expect, and the CONTINUITY-TEST function has the requisite audible indicator.

More interesting are the PEAK HOLD and DATA HOLD functions. Those will freeze either a high reading or a current reading on the display. The PEAK-HOLD function will work only when the meter is in the manual mode and only for AC and DC voltage, AC and DC current, and temperature (more on that in a moment). Further, it will capture any transitory reading that has a duration of greater than 5 ms.

Since we've already alluded to it, let's next turn to the TEMPERATURE function. The meter, through a standard k-type thermocouple (not included, but available as an accessory), can measure temperature and display the result in either °C or °F. The measuring range is -50°C to 1200°C or -58°F to 2192°F. Accuracies are 0.5% ± 3 digits (°C) and 0.5% ± 5 digits (°F).

Relative voltages can be displayed using the DBM function. In that function, all readings are referenced to 0 dBm (0.7746-volts rms at 600 ohms, 1 mW).

A REL or relative function relates all subsequent measurements to an input reference. That function



NOTE: Monitor not available. The Plus/4™ can hook up to your TV.

## COMMODORE PLUS/4™ COMPUTER SYSTEM AT BELOW DEALER COST!

Factory new! Factory warranted by Commodore. Built-in software for word processing, data processing, spreadsheets and 128 color graphics. Ideal for home or business. Perfect for beginners. A terrific value!

Commodore designed this Plus/4™ specifically for programmers and small businesses! Then they made it VERY EASY for a novice to learn and use. Popular business software is available for a variety of purposes. For programmers, this machine has easy-to-use powerful commands and 60K of usable memory. Can access as many as four disk drives.

Team up the computer with our famous Brand Name compatible units, the DISK DRIVE and DOT MATRIX PRINTER! Both units are completely factory reconditioned with warranty. Sorry, we can't print the brand name of the disk drive and printer. But phone us Toll-Free and we can tell you. With Disk Drive for data storage and Printer for "hard copies", you'll have a complete system...at LOW liquidation prices! Order TODAY!

Original List Price For Entire System ..... **\$837.00**

Plus/4™ Computer, Disk Drive and Printer Liquidation Price ..... **\$299**

Item H-1442-5035-258 Ship, handling: \$20.00

### Additional Features of COMMODORE PLUS/4™

Data base of 999 records. Computer holds 99 lines of text before it must be transferred to disk drive. Excellent terminal for use with modem. 128 colors available for graphics. Split screen and window capabilities. Compatible with all Commodore hardware except joystick and dataset. NOT compatible with C64 software.

### DISK DRIVE

External 5 1/4" floppy diskette recorder. 2K RAM, 16K ROM. Maximum storage of 170K formatted data: 35 tracks. Uses single-sided, single-density disk. Serial interface. Second serial port for chaining second drive or printer. Data transfer rate of 400 bytes per second.

### DOT MATRIX PRINTER

Uni-directional. Prints 30 characters per second. Creates upper and lower case letters, numerals, symbols and graphics. 10 characters per inch. Tractor feed. Maximum of 80 columns. Accepts paper 4 1/2" to 10" wide.

### TO ORDER

#### INDIVIDUAL COMPONENTS: PLUS/4™ COMPUTER

Mfr. List ..... **\$299.00**

Liquidation Price ..... **\$79**

Item H-1442-5035-001 Ship, handling: \$8.00

#### DISK DRIVE

Mfr. Orig. List ..... **\$269.00**

Liquidation Price ..... **\$149**

Item H-1442-3553-013 Ship, handling: \$8.00

Credit card customers can order by phone, 24 hours a day, 7 days a week.



Toll-Free: 1-800-328-0609

Sales outside the 48 contiguous states are subject to special conditions. Please call or write to inquire.

SEND TO: Item H-1442

C.O.M.B. Direct Marketing Corp.  
1405 N. Xenium Lane/Minneapolis, MN 55441-4494

Send the following items. (Minnesota residents add 6% sales tax. Sorry, no C.O.D. orders.)

Send  COMPLETE SYSTEM(s) Commodore Plus/4™, Disk Drive, Printer. Item H-1442-5035-258 at \$299 each plus \$20 each for ship, handling.

Send  COMMODORE PLUS/4™ COMPUTER(s) Item H-1442-5035-001 at \$79 each plus \$8 each for ship, handling.

Send  DISK DRIVE(s) Item H-1442-3553-013 at \$149 each plus \$8 each for ship, handling.

My check or money order is enclosed. (No delays in processing orders paid by check, thanks to TeleCheck.)

Charge:  VISA®  MasterCard®  American Express®

Acct. No. \_\_\_\_\_ Exp. \_\_\_\_\_

PLEASE PRINT CLEARLY  
Name \_\_\_\_\_

Address \_\_\_\_\_

City \_\_\_\_\_

State \_\_\_\_\_ ZIP \_\_\_\_\_

Phone (\_\_\_\_) \_\_\_\_\_

Sign Here \_\_\_\_\_



can only be selected when the meter is in the manual mode and will work on AC and DC current and voltage ranges as well as on the resistance range.

One disadvantage of a 4½-digit meter such as this one is that it takes a relatively long time to obtain a reading. Maximum response times can range from one to as many as eight seconds. For instances where speed is more important than a high degree of

accuracy, the meter can be placed in a 3½-digit mode. In that mode, the least significant display digit is blanked and response times are significantly shortened.

Last, but certainly not least, the 3430 features a FREQUENCY mode. In that mode, the meter acts as a 100-kHz (actually, a 99.999-kHz) frequency counter. Accuracy is specified as 0.05% of reading and resolutions as high as 0.001 Hz are possible.

## Odds and ends

The large LCD readout is capable of displaying a full range of annunciators. In addition to showing range, function, etc., such conditions as overvoltage and low battery are clearly indicated when appropriate. The input connectors are of the recessed safety type.

All functions and modes are selected using a front-panel keypad. Operation in both AUTO and MANUAL modes is simple and straightforward.

Battery life is estimated to be 100 hours with alkaline units. An optional AC adapter is available also.

The instruction manual is nothing special. To make things worse, because of a poor translation job (both the manual, and the meter were produced in Japan) it takes quite a bit of effort to get the most out of the manual and hence the meter.

But don't let that stand between you and this outstanding instrument. At \$339.00, the model 3430 is the answer to many a technician's wish list.

R-E

*continued on page 32*

# VCR REPAIR MADE EASY

**Sams is your source for reliable, state-of-the-art service data for major VCR brands.**

The Sams PHOTOFAC<sup>®</sup> standard notation format, your tool for 40 years for television and computer repairs, is now being applied to VCR servicing.

Technicians! VCR schematics, troubleshooting data, and parts listings keep you from having to adapt to different schematic styles and layouts each time you service equipment from a different manufacturer.

Become familiar with all the brand-name equipment, delete the guesswork in troubleshooting, and build customer loyalty fast from quality service in this rapidly growing market for VCR repair.

You can depend on the reliability of Sams VCR Technical Service Data. The service data is created in our own labs by Sams engineers. Every board, component location, every grid and waveform is checked and re-checked.

Faster Repairs. More Business. More Profit!

Repair Made Easy . . .

- Color coding of test point locations/voltage measurements and GridTrace™ are exclusive methods of reading schematics and locating components with "road map" coordinates. Circuit boards are depicted in a component-side view.
- Easy-Read Waveforms - Clear reproductions show you exactly what your test waveform should look like.
- Replacement Parts Cross References - Give you choices for equivalent components without costly and time consuming trial and error.
- VCR manuals are approximately 80 pages, 8½ x 11, and loose-leaf bound for easy use. Each manual covers one VCR model.

Sams VCR Technical Service Data is available for \$21.95 each from local electronics distributors, book stores, or from Sams. Ask for details on the "Bonus-Buy Plan" for volume discounts and for Standing Order information.

## TECHNICIANS!

Register to win one of 6 valuable test instruments.

Just complete the order form attached and mail to Sams or call 800-428-SAMS or in Indiana, call 317-298-5566. Ask for Operator 888.

### GRAND PRIZE

**SENCORE**  
Universal NTSC Video Analyzer  
Model VA62

Other Prizes

- B & K PRECISION-NTSC Signal Generator-Model 1251
  - SIMPSON-Digital Multimeter-Model 464 D-3
  - FLUKE-Digital Multimeter-Model 8060A
  - TEGAM, INC.-Digital Multimeter-Model 130A
  - TRIPLETT-Digital Multimeter-Model 3360
- Test equipment is supplied to Sams by each manufacturer.

**SAMS**

Howard W. Sams & Co.  
A Division of Macmillan, Inc.  
4300 West 62nd Street  
Indianapolis, IN 46268

### Register to win FREE test equipment.

Name \_\_\_\_\_  
Company \_\_\_\_\_  
Your Title \_\_\_\_\_  
Address \_\_\_\_\_  
City \_\_\_\_\_  
State \_\_\_\_\_ Zip \_\_\_\_\_  
Phone \_\_\_\_\_

List the VCR brands you would like Sams to cover to be eligible to win valuable test equipment. Entries must be received by November 1.

Brand	Model	Brand	Model
_____	_____	_____	_____
_____	_____	_____	_____

Mail to: **Howard W. Sams & Co.**  
Department DM  
4300 West 62nd Street  
Indianapolis, IN 46268

Or Call: 800-428-SAMS  
Ask for  
Operator 888

## Learn micro-processing with the new MICRO-PROFESSOR 1P



Students, engineers or technicians—upgrade your micro-processing skills with the new Micro-Professor 1P.

The MPF-1P features:

- extensive software support
- more built-in memory
- improved keyboard
- larger display

Three tutorial guides help cover all capabilities. The ideal training tool! MPF-1P will deliver you into the growing world of micro-processing. Invest now!

**Plus—FREE GIFT Only \$199.95**

Check this box for FREE Z-80 Microprocessor Programming and Interfacing textbook when you order within 7 days. \$16.95 value. (Include \$7.50 postage & handling)

**ETRONIX**  
Dept. RE0886  
5326 9th Ave. N.E.  
Seattle, WA 98105-3617

For immediate action call TOLL FREE:

**1-800-426-1044**

Full money back guarantee. Pictured with optional printer.



CIRCLE 111 ON FREE INFORMATION CARD

MASTER THE NEW ELECTRONICS WITH MCGRAW-HILL'S

# Contemporary Electronics Series

The fast, easy and low cost way to meet the challenges of today's electronic innovations. A unique learning series that's as innovative as the circuitry it explains, as fascinating as the experiments you build and explore.

From digital logic to the latest 32-bit microprocessor, the McGraw-Hill Contemporary Electronics Series puts you into the electronic picture one easy step at a time. Fifteen unique Concept Modules, sent to you one every 4-6 weeks, give you a handle on subjects like optoelectronics, robotics, integrated circuits, lasers, fiber optics and more.

Each Concept Module goes right to the heart of the matter. You waste no time on extraneous material or outdated history. It's a fast, efficient, and lively learning experience... a non-traditional approach to the most modern of subject matter.

### Unique Interactive Instruction

With each module, you receive a McGraw-Hill Action Audio Cassette. Each tape is a dynamic discussion that drives home the key facts about the subject. Your learning

With your first module, you get this solderless breadboarding system. You'll use it throughout the series to build electronic circuits and bring concepts to life.

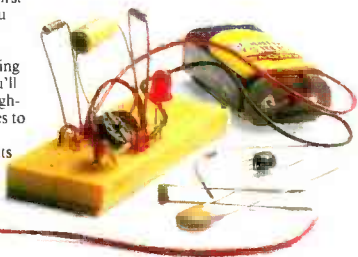

experience is reinforced through interaction with vividly illustrated text, audio cassettes, and actual electronic experiments. Indexed binders preserve backup material, notes, and tapes for convenient referral.



### Perform Experiments in Contemporary Electronics

Throughout your series, laboratory experiments reinforce every significant point. This essential experience... dynamic, hands-on demonstrations of theory in practice... will help you master principles that apply all the way up to tomorrow's latest VLSI (Very Large Scale Integrated) circuitry.

In your very first module, you'll use integrated circuits to build a digital oscillator, verifying its operation with a light emitting diode (LED). You'll learn to identify passive and active components, understand concepts common to all electronic circuits.

### For Anyone Interested in Electronics

The Contemporary Electronics Series is designed for anyone from hobbyist to professional. It's for you if you're looking for new fields of interest... if you're a teacher who

wants an update in contemporary circuits... a manager or supervisor in an electronics plant... a doctor, an engineer, a chemist who finds electronics playing an increasingly important role in your work. It's even for electronics engineers or technicians who feel their training needs freshening up. It's the quickest, most convenient, probably least expensive way to do it. And the only one that gives you hands-on experience.



### 15-Day No-Risk Trial

To order your first module without risk, send the postage-paid card today. Examine it for 15 days under the terms of the order form and see how the Contemporary Electronics Series gets you into today's electronics. If card has been used, write us for ordering information.



McGraw-Hill  
Continuing Education Center  
3939 Wisconsin Ave.  
Washington, D.C. 20016

## Vector SMT Prototyping Kit

Learn about surface-mount technology with hands-on experience.

CIRCLE 10 ON FREE INFORMATION CARD



Circuit) and PLCC (Plastic Leaded Chip Carrier) IC's. Of course the kit also includes solder, solder paste, terminal pins, stainless steel and plastic tweezers, and conductive adhesive.

The most important part of the SMT Training Kit, however, is the training manual. For the most part, it is very well written. It begins

WHETHER YOU ARE AN ELECTRONICS engineer, technician, or, perhaps, even a hobbyist, you're no doubt aware that Surface Mount Technology (or SMT) is becoming increasingly important in the fight to cram more circuitry into a given space. It's important for anyone with an eye on the future to get hands-on experience with surface-mount devices. We recently examined what we think is a superb way to get that experience: the SMT2000 SMT Training Kit from Vector Electronic Company (12460 Gladstone Ave., P.O. Box 4336, Sylmar, CA 91342-0336).

The SMT Training Kit contains an assortment of surface-mount devices, prototyping boards, interconnection materials, and a training manual. The devices supplied with the kit include almost three hundred chip capacitors, three hundred 1/8-watt, thick-film resistors, ten 1N914 diodes in SOT-23 packages, and ten 2N2222 transistors, also in SOT-23 packages.

Although there are no surface-mount IC's supplied with the kit, the double-sided epoxy-glass prototyping PC boards have tinned foil patterns to accommodate SOIC (Small Outline Integrated

Vector	SMT Training Kit									
OVERALL PRICE	[Bar chart showing a score of approximately 8.5]									
EASE OF USE	[Bar chart showing a score of approximately 8.5]									
INSTRUCTION MANUAL	[Bar chart showing a score of approximately 8.5]									
PRICE/VALUE	[Bar chart showing a score of approximately 8.5]									
	1	2	3	4	5	6	7	8	9	10
	Poor		Fair			Good			Excellent	

with a general description of surface mount technology and surface-mount devices, including packaging schemes and manufacturing processes. It then describes the kit and gives hints on how to

## WM. B. ALLEN has unbelievable prices on LEADER!

**LEADER**  
Instruments Corporation

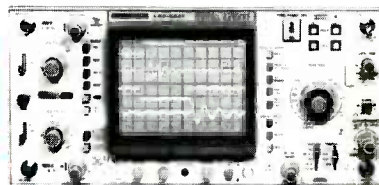

**LBO5825** TWO CHANNEL DIGITAL STORAGE OSCILLOSCOPE  
5MHz sampling rate, 35MHz analog bandwidth, A/D converter each channel, 1k word per channel, two channels, Memory protect, X-Y recorder, Roll function, 5MHz storage.  
REGULARLY \$2850.00  
NOW ONLY \$2565.00

**LPS151** TRIPLE OUTPUT POWER SUPPLY  
0 to +6V, 0 to +25V  
0 to -25V all adjustable,  
0 to 6V output-3.0A max.,  
+25V-0.5A max.  
REGULARLY \$425.00  
NOW ONLY \$392.00

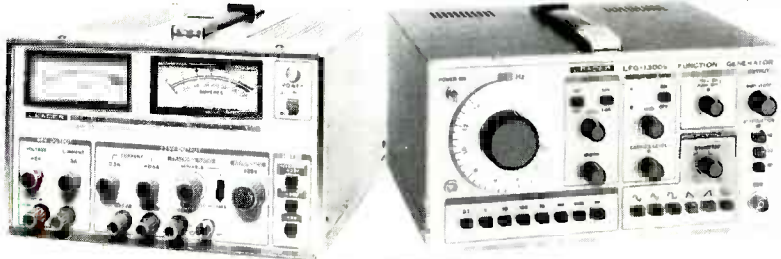

**LFG1003** FUNCTION/SWEEP GENERATOR  
Sine, square, triangle, ramp and pulse output, Adjustable pulse width, Linear or log sweep, 1000:1 range.  
REGULARLY \$495.00  
NOW ONLY \$426.00

**LAG-27** SINE/SQUARE WAVE GENERATOR 1 MHz  
10MHz -1MHz range, 600 Ohm output impedance approx., Square wave frequency range 10Hz-100KHz, Output voltage 5V p-p or more (unloaded).  
REGULARLY \$225.00  
NOW ONLY \$207.00

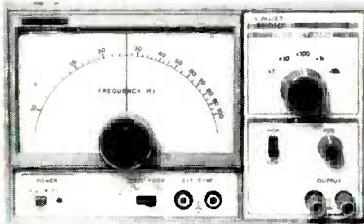

FOR PRICES ON OTHER LEADER PRODUCTS, CALL WM. B. ALLEN TOLL FREE!

NATIONWIDE 800-535-9593  
NEW ORLEANS 504-525-8222  
LOUISIANA 800-462-9520

**WM. B. ALLEN SUPPLY COMPANY, INC.**

ALLEN SQUARE  
300 BLOCK, N. RAMPART STREET  
NEW ORLEANS, LA 70112



CIRCLE 103 ON FREE INFORMATION CARD

use it most effectively. A SMT resource directory is included in the manual. It contains a listing of manufacturers and suppliers of SMT products.

### Getting some experience

Let's look at an example of how the kit can give some practical hands-on experience. (We will assume that you have the IC's that you'll need to complete your circuit.) The first step is to plan the board layout by drawing it on the layout paper that's provided. Once that's done, you're ready to mount components. If you've never worked with surface mount devices, it can be a real learning experience. For example, since surface-mount components don't have mounting holes to hold them in place, there's no easy way to get them to stay in place while you solder them. Tack soldering works—once you get the hang of working with chip components—but it's not the easiest way. That's especially true if you're working with IC's with "J" leads, which bend in under the package. There are two compounds—solder paste and conductive adhesive—that let you get you components mounted in place reliably.

Solder paste is a mixture of tin/lead solder and flux, and there are two common ways to use it. The first is to apply the paste to the solder pads using a syringe. The other is simply to dip the component contacts into the paste. Once your components are "pasted" on the board, the real soldering begins—but not with a soldering iron!

*Solder reflow* is the method used to melt the solder paste. First, the entire board is pre-heated in a convection oven (85°C for about 20 minutes) to drive off undesirable volatile solvents, to lessen thermal shock to the board and its components, and to get better solder contacts. After pre-heating, the oven temperature is increased to about 210°C to melt the solder. Solder reflow should occur within about 30 seconds. You have to be careful and quick—electronic components cannot withstand the temperature of molten solder for very long. (If a con-

*continued on page 38*

# Free Famous hi-tech catalog



**A very special computer & electronics guide that shows you what the exciting world of kitbuilding can do for you.**

Challenge. Knowledge. Achievement. Enjoyment. All of these things are yours when you build a Heathkit high-quality product. Our colorful, informative catalog reflects the years of experience and technological expertise that make these things happen for you.



**HERO® 2000 Educational Robot and Courseware**

**IBM-PC Compatible Expandable Computers**

**Amateur Radio Terminal Node Controller**

**Precision Test Instruments**

**Electronic Keyless Doorlock**

In our catalog you'll find over 450 interesting and useful items – from computer hardware and software to robots and test instruments, and from home security systems to color tv's and amateur radio equipment.

But what makes Heath Company unique is that we offer you the confi-

dence and pride that you can only get by building a state-of-the-art product yourself. And you're backed by our promise, "We won't let you fail!"

The Heathkit Catalog is a simple – and FREE – first step toward this excellent opportunity.

**Send NOW for your FREE Heathkit Catalog**



**Yes!** I want to see what kitbuilding can do for me. Please send me the latest Heathkit Catalog Free.

Send to: Heath Company, Dept. 020-452  
Benton Harbor, Michigan 49022

Name \_\_\_\_\_

Address \_\_\_\_\_

City \_\_\_\_\_ State \_\_\_\_\_

Zip \_\_\_\_\_

**Heathkit®**  
Heath  
Company

A subsidiary of Zenith Electronics Corporation

CL-787R1

CIRCLE 86 ON FREE INFORMATION CARD

# NEW PRODUCTS



CIRCLE 30 ON FREE INFORMATION CARD

**OSCILLOSCOPE INTERFACE**, the model *IC-4802*, is an interface that turns the computer into a dual-trace 50-MHz storage oscilloscope with a 7-nanosecond rise time. It

adds testing capabilities to any IBM PC-compatible computer, and can make a computer an integral part of any engineering workstation. The Computer Oscilloscope

is available as a kit (*IC-4802*) or in assembled form (*SC04802*).

Supplied software enables full programmability of the oscilloscope from the keyboard of the computer. The computer displays the dual traces, one for each channel, on an 8 × 10 division graticule. There are three display modes: Y1, Y2, and DUAL. All displays are chopped except for the highest time-base range, which uses an alternate display. Waveforms can be stored on a floppy disk for later use as a reference or for waveform manipulation, such as signal averaging.

The model *IC-4802* (kit) is priced at \$399.00; the model *SC-4802* (assembled) costs \$575.00—**Heath Company**, Benton Harbor, MI 49022.

## Why Settle for Second Best?

**Introducing lower pricing on 3M's A P Products™ line of quality breadboards.**

A P Products invented solderless breadboarding. We understand the finest details of the design. We build our A•C•E Board™ 200 Series with absolute reliability in mind and we stand behind every breadboard we make. Every A•C•E Board we make is consistently reliable time after time, design after design, contact to contact. No import can make this claim.

Now we're giving you the opportunity to purchase the finest solderless breadboards made for approximately the same as you would have to pay for second best.

Compare, and you'll agree. After all, you wouldn't submit a design that's only second best. If you haven't got A P Products brand A•C•E Boards, now's your chance to

experience our quality and reliability at a really affordable price.

Call your A P Products Prototype & Test Devices dealer today. For immediate response telephone 800-321-9668, or (216) 354-2101 in Ohio.

**We Solve Problems**

CIRCLE 76 ON FREE INFORMATION CARD

[www.americanradiohistory.com](http://www.americanradiohistory.com)

**Associated Electronics/3M**

A P Products Prototype & Test Devices  
9325 Progress Parkway  
P.O. Box 540  
Mentor, Ohio 44060

**COLOR-TV SET**, the model KV-25VXR is combined with an 8mm VCR that provides all standard 8mm features, including four-hour recording (on a P6-120 videocassette), as well as digital audio-stereo recording capability and a new head design for a noiseless still picture.



CIRCLE 31 ON FREE INFORMATION CARD

The deck shares a 181-channel cable-compatible tuner/timer with the TV set for recording regular TV and cable programs for later playback. It can be programmed up to three weeks in advance to record as many as four programs off the air automatically. Nineteen step-by-step on-screen displays, such as "Timer has not been set," and "Please insert a tape," make the programming procedure almost foolproof.

The TV set itself is a 27-inch screen model and features a digital picture-in-picture (PIP) capability. PIP allows users to watch one channel while also displaying a small image of another channel in a corner of the screen.

The model KV-25VXR has a suggested retail price of approximately \$2200.00.—**Sony Corporation of America**, Sony Drive, Park Ridge, NJ 07656.

**STEREO HEADPHONES**, the model ATH-M7 PRO, is a moving-coil device with extended frequency response and distortion-free sound through a combination of design features that include a self-supporting voice coil, and a low-mass, high-compliance diaphragm. A tangential surround ensures linear diaphragm motion.

## Analyze defective waveforms faster, more accurately, and more confidently — every time or your money back



with the SC61 Waveform Analyzer  
Patented \$2,995

**If you value your precious time, you will really want to check out what the exclusively patented SC61 Waveform Analyzer can do for you. 10 times faster, 10 times more accurate, with zero chance of error.**

**End frustrating fiddling with confusing controls.** Exclusive ultra solid ECL balanced noise cancelling sync amplifiers, simplified controls, and bright blue dual trace CRT help you measure signals to 100 MHz easier than ever.

**Accurately and confidently measure waveforms from a tiny 5 mV all the way to a whopping 3,000 V without hesitation** with patented 3,000 VPP input protection — eliminates expensive "front end" repairs and costly equipment downtime.

**Make only one circuit connection and push one button for each circuit parameter test:** You can instantly read out DC volts, peak-to-peak volts and frequency 100% automatically with digital speed and accuracy. It's a real troubleshooting confidence builder.

**Confidently analyze complex waveforms fast and easily.** Exclusive Delta measurements let you intensify any waveform portion. Analyze glitches, interference signals, rise or fall times or voltage equivalents between levels; direct in frequency or microseconds.

**Speed your digital logic circuit testing.** Analyzing troublesome divide and multiply stages is quicker and error free — no time-consuming graticule counting or calculations. Simply connect one test lead to any test point, push a button, for test of your choice, for ERROR FREE results.

To see what the SC61 can do for your troubleshooting personal productivity and analyzing confidence, **CALL TODAY, WATS FREE, 1-800-843-3338**, for a FREE 15 day Self Demo.



Call Today Wats Free 1-800-843-3338

**SENCORE**

3200 Sencore Drive  
Sioux Falls, SD 57107  
605-339-0100 In SD Only

*innovatively designed  
with your time in mind.*

CIRCLE 188 ON FREE INFORMATION CARD



CIRCLE 32 ON FREE INFORMATION CARD

A soft, semi-elastic pad on each earpiece provides a seal against ambient noise without exerting undue pressure. The frequency response is essentially flat over a 20–20,000 Hz range. A padded headband and adjustable side extensions permit a precise, self-adjusting fit.

The model *ATH-M7 PRO* is

priced at \$99.95.—**Audio-Technica U. S., Inc.**, 1221 Commerce Drive, Stow, OH 44224.

**DC POWER SUPPLY**, the model 1630, features regulated voltage



CIRCLE 33 ON FREE INFORMATION CARD

and current outputs that can supply a maximum of 30 volts and 3 amps respectively. In addition, the model 1630, has built-in metering; two current ranges; a pre-regulator to limit internal dissipation; isolated outputs so that either po-

larity may be floated or grounded; and reverse-polarity protection to prevent damage to the power supply from an external voltage or a reversed polarity input.

It also has fully-adjustable current limiting (from 5% to 100% of maximum output current) that protects the circuit under test and the power supply. The model 1630 can be hooked up in series or in parallel with another model 1630 for 0–30-volt, 6-amp, or 0–60-volt, 3-amp operation.

The model 1630 comes with test leads, spare fuse, schematic and parts list, and complete instruction manual. It is priced at \$225.00.—**B&K Precision, Dynascan Corporation**, 6460 West Cortland Street, Chicago, IL 60635.

**VIDEO MONITOR/RECEIVER**, the model *YM-950*, is a 25-inch color stereo unit with MTS (Multichannel Television Sound) and SAP (Separate Audio Program) capabilities, as well as infrared remote control.

The 134-channel cable-ready receiver features a complete set of

CABLE BOXES

\$129<sup>95</sup>

NEW!  
with  
VOLUME CONTROL  
Just In!



JERROLD CORDLESS CABLE TV CONVERTER Model DRX3-105/400

- 58 channels



\$69<sup>95</sup>

JERROLD CORDLESS CABLE TV CONVERTER Model DRZ/450

\$69<sup>95</sup>

10 lot  
79<sup>95</sup> ea.

- 66 CHANNELS
- AUTOMATIC FINE TUNING
- A/B SWITCH OPTION



TEKNICA CORDLESS CABLE TV CONVERTER Model 6510



\$139<sup>95</sup>

- VOLUME CONTROL
- 140 CHANNEL CAPABILITY

B&K PRECISION B&K DUAL TRACE SCOPES



SPECIAL!

PROBES INCLUDED

1476-10MHz—\$375

1477-15MHz—\$425

1479-30MHz—\$550 DELAYED SWEEP

HITACHI 100-60-40-20 MHz SCOPES



V-212-20 MHz—\$460

V-222-20 MHz—\$535

V-223-20 MHz—\$599 DELAYED SWEEP

V-422-40 MHz—\$689

V-423-40 MHz—\$749 DELAYED SWEEP

V-650-60 MHz—\$950 DELAYED SWEEP

V1050-100 MHz—\$1250 DELAYED SWEEP QUAD TRACE

PROBES INCLUDED

OMNITRON

ELECTRONICS

770 Amsterdam Ave., New York, NY 10025

SHIPPING CHARGES

For Orders	Add
\$25-100	\$6.50
\$100-500	\$8.50
\$500-750	\$10.50
\$750 and up	\$20.00

Write for  
**FREE CATALOG**  
136 page

MASTER CARD ■ VISA

CIRCLE 110 ON FREE INFORMATION CARD



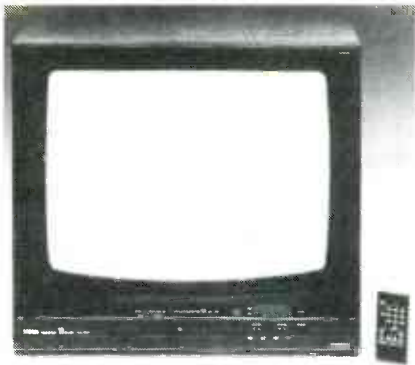

CIRCLE 34 ON FREE INFORMATION CARD

input and output jacks, some of which, along with the conventional TV controls, are hidden behind a flip-down lid on the front panel. Connections to and from an audio system, a VCR, a videodisc player, a game, and a computer can be made easily and quickly.

The model YM-950 has a suggested retail price of \$950.00.—**Yamaha Electronics Corp., USA**, 6660 Orangethorpe Avenue, Buena Park, CA 90620.

#### SCANNER BEAM ANTENNA

provides 30–50 MHz low band, 108–136 MHz aircraft, 136–174 MHz high band, 225–400 MHz military aircraft and satellites, 406–512 MHz UHF, and 806–960 MHz microwave

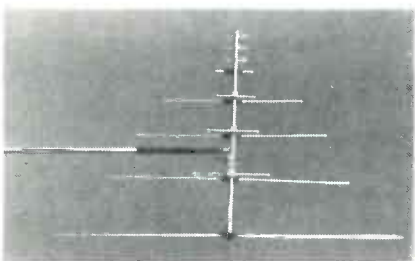

CIRCLE 35 ON FREE INFORMATION CARD

mobile reception. Hams can use it for transmitting up to 25 watts on the 144-, 220-, and 420-MHz bands. The *Scanner Beam* can also be used with an inexpensive TV antenna rotator, if desired.

A balun transformer, offset pipe, and all mounting hardware are included. (A type F connector on the user's coax is required.) The approximate size of the *Scanner Beam* is 6' x 4". It is priced at \$40.00 plus \$3.00 shipping via UPS or \$6.00 via the U.S. Post Office, within the U.S.—**Grove Enterprises**, P.O. Box 98, Brasstown, NC 28902.

R-E

**Exclusive, triple patented dynamic cap and coil analyzing . . . guaranteed to pinpoint your problem every time or your money back**

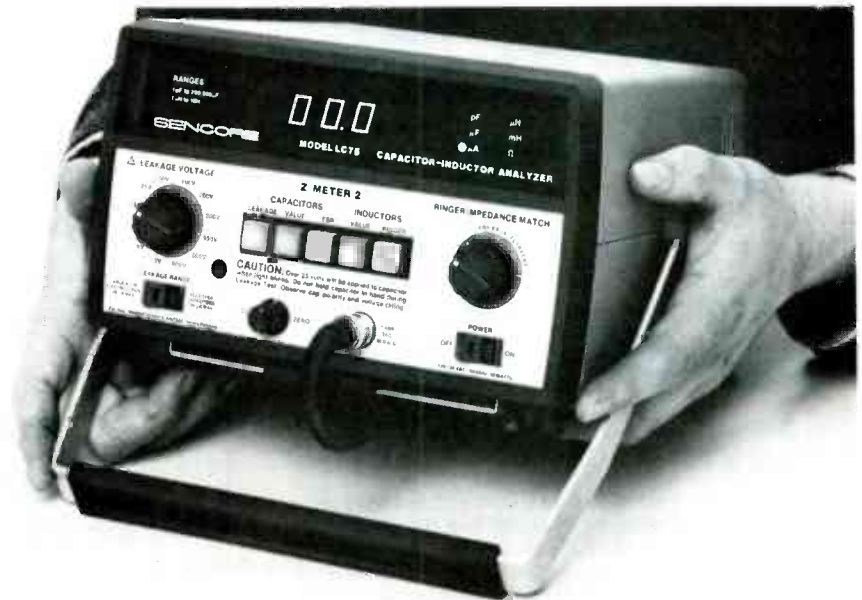

with the all new LC75 "Z METER 2"  
Capacitor Inductor Analyzer  
Patented \$995

The "Z METER" is the only LC tester that enables you to test all capacitors and coils dynamically — plus, it's now faster, more accurate, and checks Equivalent Series Resistance (ESR) plus small wire high resistance coils.

Eliminate expensive part substitution and time-consuming shotgunning with patented tests that give you results you can trust every time. Test capacitor value, leakage, dielectric absorption, and ESR dynamically; with up to 600 volts applied for guaranteed 100% reliable results — it's exclusive — it's triple patented.

Save time and money with the only 100% reliable, in- or out-of-circuit inductor tester available. Dynamically test inductors for value, shorts, and opens, automatically under "dynamic" circuit conditions.

Reduce costly parts inventory with patented tests you can trust. No more need to stock a large inventory of caps, coils, flybacks, and IHVTs. The "Z METER" eliminates time-consuming and expensive parts substituting with 100% reliable LC analyzing.

Turn chaos into cash by quickly locating transmission line distance to opens and shorts to within feet, in any transmission line.

Test troublesome SCRs & TRIACs easily and automatically without investing in an expensive second tester. The patented "Z METER 2" even tests SCRs, TRIACs, and High-Voltage Diodes dynamically with up to 600 volts applied by adding the new SCR250 SCR and TRIAC Test Accessory for only \$148 or FREE OF CHARGE on Kick Off promotion.

To try the world's only Dynamic LC Tester for yourself, CALL TODAY, WATS FREE, 1-800-843-3338, for a FREE 15 day Self Demo.



Call Today Wats Free 1-800-843-3338

**SENCORE**

3200 Sencore Drive  
Sioux Falls, SD 57107  
605-339-0100 In SD Only

*innovatively designed  
with your time in mind.*

CIRCLE 189 ON FREE INFORMATION CARD

# CHOOSE AUGAT<sup>®</sup> PACKAGED PRODUCTS



INDUSTRIAL  
**QUALITY**  
GRADE PRODUCTS

**Sockets, Switches, Knobs, IDC Products,  
— and now RDI Terminal Blocks**

**PLUS**

a full line of DATA Cable Products featuring Coaxial and RS-232C Cables, D-Subs, Edge Cards, B & C Connectors and Gender Changers.



EVERYTHING  
IN STOCK

SEND FOR  
CATALOG,  
REP &  
DISTRIBUTOR  
LIST

**Over 1300 Products Available**

**Ask for AUGAT at your favorite  
Electronics Store**

**Guaranteed  
Source of Supply**

for Sockets, Interconnection Products, IDC Products, AlcoSwitches, Lamps, Knobs, RDI Terminal Blocks. . . and much more!

**AUGAT<sup>®</sup> PACKAGED PRODUCTS**

P.O. Box 659, 33 Perry Avenue  
Attleboro, MA 02703. (617) 222-9635 or 222-9636

CIRCLE 197 ON FREE INFORMATION CARD

## EQUIPMENT REPORTS

continued from page 33

### Employers

Willing workers available now at as little as 1/2 your usual cost.

This is your chance to get help you've needed, but thought you couldn't afford.

No business too large or too small. Call your private industry council or write National Alliance of Business, P.O. Box 7207, Washington, D.C. 20044

A Public Service of  
This Publication

**Ad  
Council**

vection oven is not available, a hot plate can be used.) After you remove the board from the oven and let it cool, you must remove the solder flux and carefully inspect all solder bonds.

*Conductive adhesive*, as its name implies, is a compound that lets you simply "glue" components to the board. Unfortunately, the adhesive was not included with our pre-production version of the *SMT Training Kit*. The compound is made up of two parts: a liquid activator, and the adhesive. When the activator contacts the adhesive, a conductive bond is formed.

Judging from the manual's instructions, using the adhesive requires care and a steady hand, but using it is the only way to go if you don't have an oven for the reflow process.

You can read volumes of literature on surface-mount technology (including "A Revolution in IC Packaging," an article that appeared in the May 1986 *Radio-Electronics*) and get a pretty good idea of what's important when working with surface-mount devices. But nothing beats hands-on experience to help you get a real understanding of all aspects of what's involved.

Our only complaint is that the kit does not include any surface IC's. We understand why it doesn't—it's impossible to know what IC's someone will want to use in a prototype circuit. But we still wish we could have tried our hand at soldering surface-mount IC's without having to go to another source for the parts.

The *SMT2000* sells for \$348. The *SMT1000*, a version of the training kit that does not include any surface-mount devices, sells for \$215. While those prices put the kits out of the range of someone who's only interested in SMT, it's a small price to pay for an electronics design engineer or technician who needs to become involved with all aspects of surface mount technology. We feel that the *SMT Training Kit* serves its intended purpose very well.

R-E

**When someone  
in your family  
gets cancer,  
everyone  
in your family  
needs help.**

Nobody knows better than we do how much help and understanding is needed. That's why our service and rehabilitation programs emphasize the whole family, not just the cancer patient.

Among our regular services we provide information and guidance to patients and families, transport patients to and from treatment, supply home care items and assist patients in their return to everyday life.

Life is what concerns us.

So you can see we are even more than the research organization we are so well known to be.

No one faces cancer alone.

AMERICAN CANCER SOCIETY

# BUILD THIS

# STUN GUN

ROBERT GROSSBLATT, and ROBERT IANNINI

Man's fascination with high voltages began with the first caveman who was terrified by a bolt of lightning. In more recent times, electronics experimenters and hobbyists have found the Tesla coil and the Van de Graaff generator equally fascinating. In this article we'll show you how to build a hand-held high-voltage generator that is capable of producing 75,000 volts at a power level as high as 25,000 watts. The stun gun can be used to demonstrate high-voltage discharge and as a weapon of self-defense. Before building one, however, you should read and pay very close attention to the warning in the accompanying text box, as well as to the description of physiological effects that follows.

*This experimental high-voltage generator can produce 75,000 volts at a peak power of 25,000 watts.*



## WARNING

THIS DEVICE IS NOT A TOY. We present it for educational and experimental purposes only. The circuit develops about 75,000 volts at a maximum peak power of 25,000 watts. The output is pulsed, not continuous, but it can cause a great deal of pain should you become careless and get caught between its output terminals. And you should never, repeat, NEVER, use it on another person! It may not be against the law in your area to carry a stun gun in public, but, if you use it on another person, you may still be liable for civil action.

To help you build, test, and adjust the device safely, we have included a number of tests and checks that must be followed strictly. Do not deviate from our procedure.

## Physiological effects

So that you may understand the danger inherent in the stun gun, let's discuss the physiological effects first. When a high voltage is discharged on the surface of the skin, the current produced travels through the nervous system by exciting single cells and the *myelin sheaths* that enclose them. When that current reaches a synapse connected to a muscle, it causes the muscle to contract violently and possibly to go into spasms.

The longer contact with the high voltage is maintained, the more muscles will be affected. If the high voltage maintains contact with the skin long enough to cause muscle spasms, it may take ten or fifteen minutes before the brain is able to re-establish control over the nerve and muscular systems.

How much power is required to cause such spasms? That's not an easy question to answer because, although it is relatively easy to make precise measurements of the power produced by a high-voltage device, it is difficult to rate the human body's susceptibility to shock accurately. Some obvious factors include age and diseases such as epilepsy. But the bottom line is simple: *The only one who fools around with a stun gun is a fool.*

The amount of energy a device delivers is actually the amount of power delivered in a given period of time. For our purposes, it makes sense to talk about energy in joules (watt-seconds). Using a fresh 9.8-volt Ni-Cd battery, the stun gun is capable of delivering peak power pulses of 25,000 watts. Actually, pulses start out at peak power and then decay exponentially. The length of the decay time depends on the components used in the circuit, the ambient temperature, the battery's capacity, and the positioning of the output contacts with respect to each other.

Assuming that the decay rate is purely exponential, the stun gun can produce about 0.5 joules of energy, provided that the battery is fully charged. Let's put that number in perspective.

Both the Underwriter's Laboratory (in Bulletin no. 14) and the U. S. Consumer Product Safety Commission state that ventricular fibrillation (heart attack) can be caused in humans by applying 10 joules of energy. Since the stun gun only generates about half a joule, you might think that a device that produces only one twentieth of the critical amount has a more-than-adequate margin of safety. *Don't bet on it.* A brief contact with the stun-gun's discharge hurts a great deal, but it takes only about five seconds of continuous discharge to immobilize someone completely.

Let's compare the stun gun's output with a similar device, called a Taser gun, which appeared on the market a few years ago. You may have seen a film demonstrating just how effective the Taser could

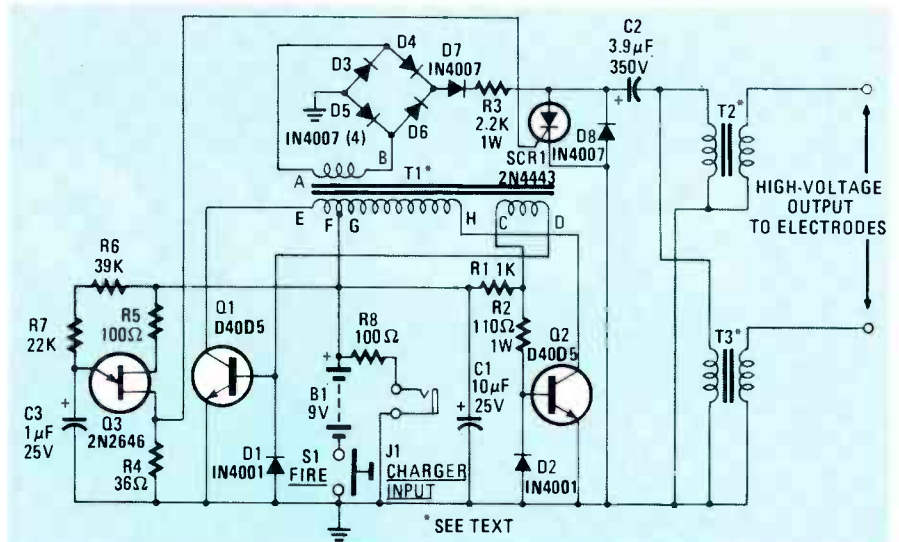

**FIG. 1—THE STUN GUN'S CIRCUIT** is a multi-stage voltage step-up circuit. The Q1/Q2 circuit produces a squarewave output of about 10 kHz, and Q3 produces 15- $\mu$ s discharge pulses at a rate of about 20 ppm. Those pulses fire SCR1, which induces a voltage in the windings of step-up transformers T2 and T3.

be as a deterrent. A foolhardy volunteer was paid an enormous sum of money to have the Taser fired at him. No matter how big, strong, (and stupid) the person was, as soon as the Taser's "darts" hit him, he would collapse to the ground and go into uncontrollable convulsions.

The energy produced by the Taser is only 0.3 joules—about 60% of what our stun gun produces! Even so, the Taser has been officially classified as a firearm by the Bureau of Tobacco and Firearms because it shoots its electrode "darts" through the air. Even though our stun gun doesn't operate that way, the Taser puts out considerably less energy than the stun gun. Keep those facts and figures in mind as you assemble and use the device.

### How it works

The schematic diagram of the stun gun is shown in Fig. 1. Basically, it's a multi-stage power supply arranged so that each succeeding stage multiplies the voltage produced by the preceding stage. The final stage of the circuit feeds two oppositely-phased transformers that produce extremely high voltage pulses. If that description sounds familiar, you've probably studied capacitive-discharge ignition systems—the stun gun works on the same principles.

The first section of the power supply is a switcher composed of Q1, Q2, and the primary windings (connected to leads E, F, G, and H) of T1. When FIRE switch S1 is closed, R1 unbalances the circuit and that causes it to start oscillating. Since base current is provided by a separate winding of T1 (connected to leads C and D), the two transistors are driven out of phase with each other, and that keeps the circuit oscillating. Resistor R2 limits base drive to a safe value, and diodes D1 and D2 are steering diodes that switch base current

from one transistor to the other. Oscillation occurs at a frequency of about 10 kHz.

The switching action of the first stage generates an AC voltage in T1's high-voltage secondary (leads A and B). The amount of voltage depends on the battery used, but a battery of seven to nine volts should produce 250 to 300 volts across T1's secondary.

That voltage is rectified by the full-wave bridge composed of diodes D3–D6. Capacitor C2 charges through D7 at a rate that is controlled by R3.

The value of capacitor C2 affects the output of the stun gun. The greater the capacitance, the more energy that can be stored, so the more powerful the discharge will be. A larger capacitor gives bigger sparks, but requires more charging time, and that gives a lower discharge rate. On the other hand, a smaller capacitor gives smaller sparks, but a faster discharge rate. If you wish to experiment with different values for C2, try 3.9  $\mu$ F (as shown in Fig. 1), 7.8  $\mu$ F, and 1.95  $\mu$ F. Those values were arrived at by using one 3.9  $\mu$ F capacitor alone, two of the same capacitors in series, and two in parallel.

Meanwhile, UJT Q3 produces 15- $\mu$ s pulses at a rate of about 20 ppm. That rate is controlled by C3 and the series combination of R6 and R7. When a pulse arrives at the gate of SCR1, it fires and discharges C2. That induces a high-voltage pulse in the primary windings of T2 and T3, whose primaries must be wired out of phase with each other. The result is a ringing wave of AC whose negative component then reaches around and forces the SCR to turn off. When the next pulse from Q3 arrives, the cycle repeats.

The outputs of the stun gun appear across the secondaries of T2 and T3. The hot leads of those transformers connect to

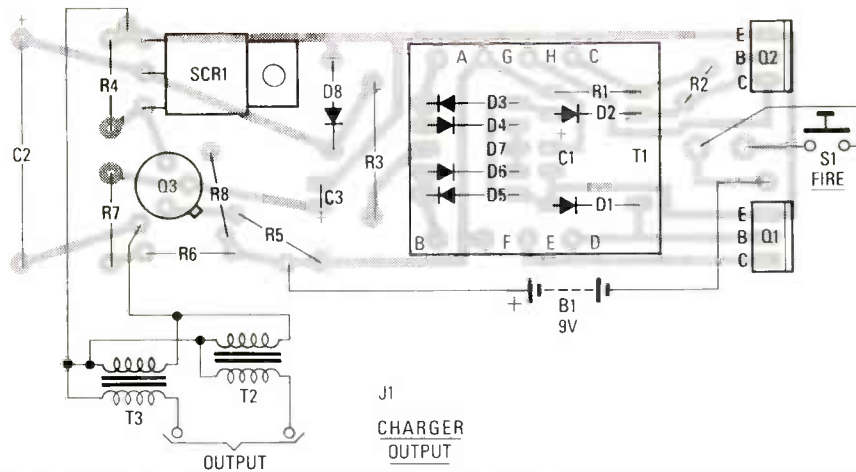

FIG. 2—MOUNT ALL COMPONENTS ON THE PC BOARD as shown here. Note that T2 and T3 are mounted off board, and that J1, C1, and D7 mount on the foil side of the board. In addition, a number of components mount beneath T1: D1–D6, R1, and R3. Those diodes and resistors must be installed before T1.

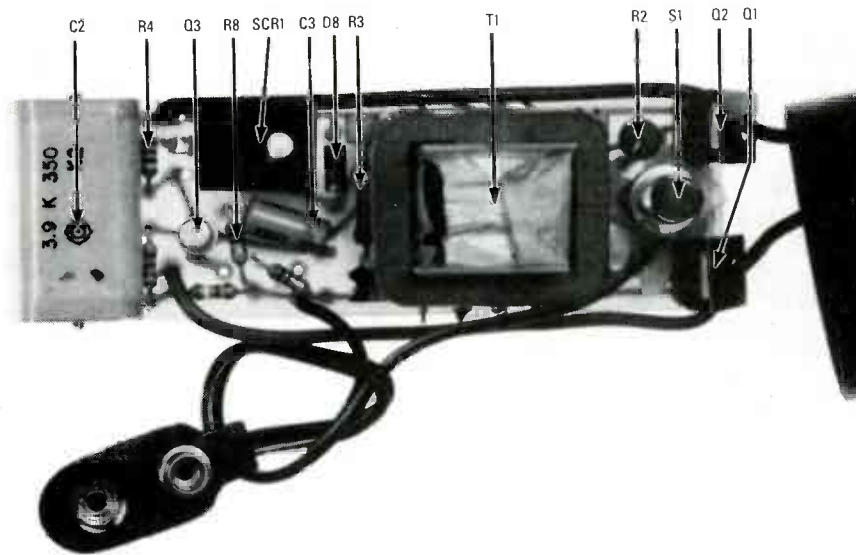

FIG. 3—BEND SCR1'S LEADS 90° so that the nomenclature faces up and then solder the SCR to the board. Also note that C3 must be bent over at a 90° angle, and that R2 is mounted vertically.

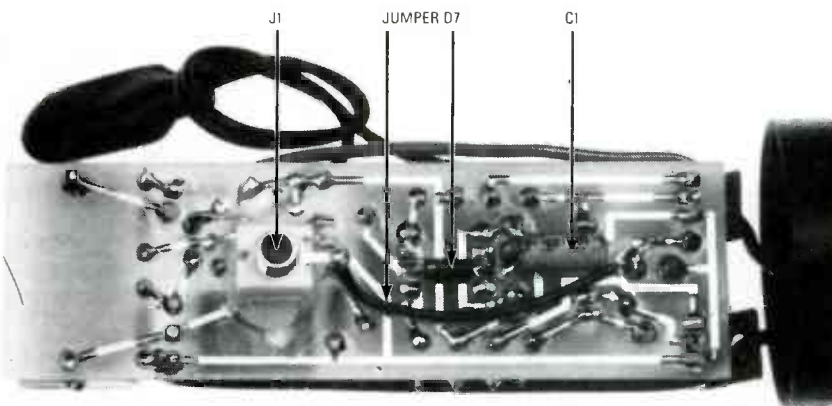

FIG. 4—JACK J1, DIODE D7, AND CAPACITOR C1 mount on the foil side of the PC board. One terminal of J1 mounts to the same pad as R8, and the jack should be glued to the board with RTV (or other high-voltage compound) after you verify that the circuit works properly.

### PARTS LIST

All resistors are 1/4-watt, 5% unless otherwise noted.

- R1—1000 ohms
- R2—110 ohms, 1 watt
- R3—2200 ohms, 1 watt
- R4—36 ohms
- R5, R8—100 ohms
- R6—39,000 ohms
- R7—22,000 ohms

### Capacitors

- C1—10  $\mu$ F, 25 volts, electrolytic
- C2—3.9  $\mu$ F, 350 volts, electrolytic
- C3—1  $\mu$ F, 25 volts, electrolytic

### Semiconductors

- D1, D2—1N4001, 50-volt rectifier
- D3–D8—1N4007, 1000-volt rectifier
- Q1, Q2—D40D5, power transistor
- Q3—2N2646, UJT
- SCR1—2N4443

### Other components

- B1—9-volt Ni-Cd battery
- S1—SPST momentary pushbutton switch
- T1—12 to 400 volts saturable-core transformer. See text
- T2, T3—50 kilovolt pulse transformer, 0.32 joules, 400-volt primary. See text

**Note:** The following components are available from Information Unlimited, P. O. Box 716, Amherst, NH 03031: T1, \$12.50; both T2 and T3, \$12.50; C2, \$1.50; PC board, \$4.50; case, \$3.50; case with T2 and T3 potted, \$17.50; charger, \$6.50; 9.8-volt battery, \$16.50; complete kit of all parts including all components, PC board, case, and charger, but no battery, \$39.50.

the output electrodes, which should be held securely in position about two inches apart, and which should be insulated from each other and from the environment with high-voltage potting compound.

### Batteries

The stun gun can be powered with almost any battery that can supply at least seven volts at one amp. A Ni-Cd battery would be a good choice; R8 and J1 will allow the battery to be recharged without removing it from the case.

The higher the battery's voltage, the higher the stun-gun's output voltage. Most nine-volt Ni-Cd's actually have a maximum fully-charged output of only 7.2 volts. However, batteries that deliver 9.8 volts when fully charged are available from several sources.

### Construction

Keep in mind the fact that the stun gun produces dangerously high voltages, and don't approach the construction of the stun gun with the same nonchalance with which you might build a light dimmer.

The circuit can be built on a PC board or on perfboard. The foil pattern for a PC

*continued on page 94*

# PHONY BURGLAR ALARM

Scare off burglars without emptying your wallet with this simple, inexpensive electronic "scarecrow."

IT'S A SAD COMMENTARY THAT THESE days a burglar alarm is becoming as common a household "appliance" as a refrigerator or a dishwasher. But burglar alarms are not inexpensive. Most will cost a few hundred dollars, and some elaborate systems could cost a thousand dollars or more.

If your household possessions are simply not worth that kind of outlay, there is a very inexpensive alternative. Most burglars are burglars because it's the easiest way they know of to make a fast buck. When they look for a house to ransack, they try to find the easiest target. The trick, then, is to make your house look like it is protected by a sophisticated alarm system. That can be done for less than \$20 with the circuit described here.

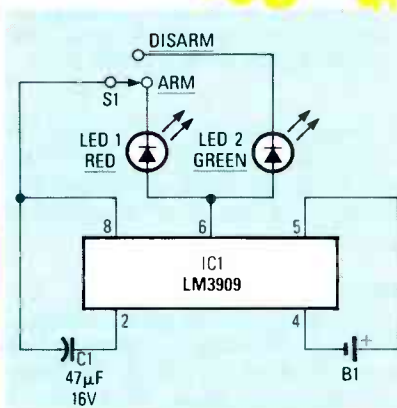

FIG. 1—IT'S NOT A REAL BURGLAR ALARM, but this "electronic scarecrow" can do almost as good a job as a real one when it comes to scaring away a burglar.

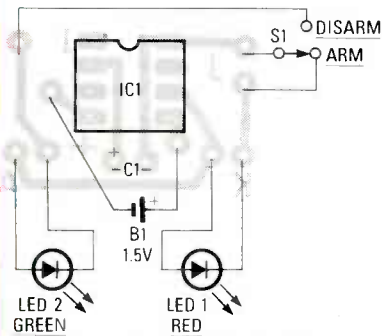

FIG. 2—THE CIRCUIT CAN BE BUILT on a tiny PC board. The pattern is provided in our PC Service section.

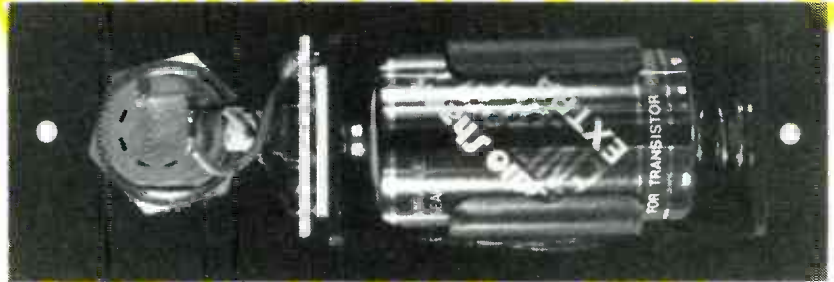

FIG. 3—THE CIRCUIT SHOULD be assembled on a piece of anodized aluminum.

## An electronic scarecrow

No burglar alarm will make your home absolutely burglar proof. If you have something a burglar wants badly, and the burglar is a professional, he'll find a way to defeat the alarm. Otherwise, an alarm's principal value is as an "electronic scarecrow." Seeing that the house is protected, a burglar will move on to easier pickings.

How does a burglar know that there is an alarm? Most alarm systems have their sensors hidden from view, so frequently the only sign of an alarm system is a status display located near the entrance. That display usually consists of a red and a green LED that show whether or not the system is armed.

By now you may have guessed where we are headed: Since the presence of an alarm-status display alone is enough sometimes to scare off a burglar, why not set up a dummy display and do away with the rest of the system? That's precisely

what our circuit does. Of course it won't give you the degree of security that a real alarm-system would, but its cost is much, much lower.

The schematic diagram of the circuit is shown in Fig. 1. The circuit is extremely simple and is built around an LM3909 LED flasher IC. With the value of C1 shown, the circuit will flash an LED at a rate of 5.5 times-per-second. It is powered by an alkaline "C"-size cell; estimated battery life is 15 months.

Switch S1 should be a key type as is typically found in burglar-alarm installations. The switch should be mounted on the dummy status-display's front panel to give the set up a more realistic look.

## Building the circuit

The circuit is simple enough to be built on a piece of perforated construction board. If you wish to use a PC board, an appropriate pattern is shown in our PC Service section. The parts-placement diagram for the board is shown in Fig. 2.

Two construction details bear special mention. One is the lead length of the LED's. They should be ¼-inch long to allow for flexibility when mounting the board (more on that in a moment). Secondly, the lead length of C1 should be kept to an absolute minimum. Be sure that the bottom of that electrolytic capacitor is flush with the board.

The circuit is mounted on a piece of anodized aluminum. Size is not critical, as long as it is appropriate for the task. The author's prototype was ½ × 4 inches. The other side of the aluminum piece will serve as the dummy status-panel.

*continued on page 98*

## PARTS LIST

- C1—47 µF, 16 volts, electrolytic
  - IC1—LM3909 LED flasher IC
  - LED1—green jumbo LED
  - LED2—red jumbo LED
  - S1—SPST, key switch
  - B1—1.5 volts, "C" cell
- Miscellaneous:** PC or perforated-construction board, anodized aluminum panel, battery holder, wire, solder, etc.
- The following are available from **Enberg Electronics, PO Box 55087, Indianapolis, IN 46205: Complete kit, including anodized aluminum cover, \$18.95; assembled unit, \$22.95; anodized cover, \$2.50; PC board, \$2.50. Indiana residents please add 5% sales tax.**

# COMMUNICATIONS:

JOSEF BERNARD

ALMOST EVERY FREQUENCY IN THE RF spectrum, from near DC to billions of cycles per second, is used for some type of communication. Indeed, at times it seems as if there are almost as many communications services as there are frequencies for them to occupy. And at times it seems that the ordering of the different services that make use of the RF spectrum is pure-

ly random. Of course it is not. There is usually a good reason for a service being located where it is. In this climb up the "electromagnetic ladder" we'll see some of the varied services that make use of the RF spectrum, and learn why they are in their particular niches.

## Meters and hertz

You no doubt have noticed that the location of a signal in the RF spectrum is

often specified in hertz, but that sometimes it is specified in *meters*. Meters are a unit of distance, as you might expect. What is being measured is the *wavelength* of the signal. A wavelength is the distance from one point on one cycle to the corresponding point on the next. See Fig. 1. On the other hand, the hertz (abbreviated Hz) is a unit of *frequency*. It indicates how many cycles occur in one second. One hertz is equal to one cycle-per-second.

## From DC to Microwave

On this guided tour of the RF spectrum we'll see what types of communications take place where, and why.



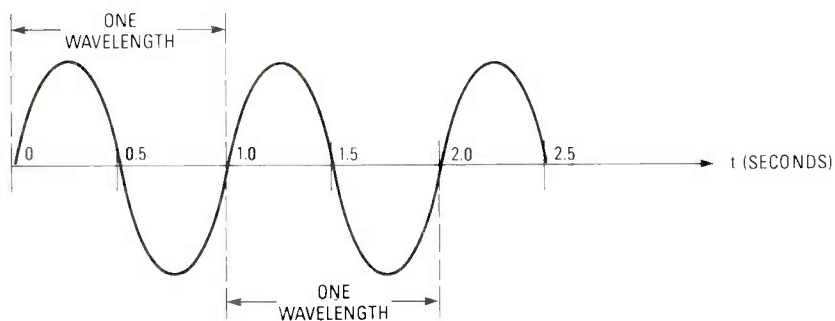

FIG. 1—THE WAVELENGTH AND FREQUENCY of a wave are related through  $f = c/\lambda$ . Therefore a wave with a frequency of one cycle-per-second (1 hertz) would have a wavelength of 300,000 kilometers.

The relationship between the two measures is simple, and if you know one you can easily determine the other. That's because the wavelength of an electromagnetic wave is inversely proportional to its frequency—that is, the longer the wavelength, the lower the frequency. The relationship between frequency and wavelength is given by  $f = c/\lambda$ , where  $f$  is the frequency in Hz,  $\lambda$  is the wavelength in meters, and  $c$  is the speed of light in meters-per-second.

Obviously, either measure can be used to specify the location in the spectrum of an RF (Radio Frequency) signal completely. Why, then, are some signals usually specified in meters while others are specified in hertz?

The main reason is simply tradition. A general rule-of-thumb is that in regions of the spectrum that have been in use the longest—for the most part since before World War II—the common usage is to describe a signal using meters. Thus, the shortwave broadcast bands, and the "high-frequency" bands used by amateur radio operators, are still usually referred to in terms of their wavelengths in meters (25, 31, 40, etc.), and shortwave receivers, which these days frequently are called "communications receivers," have their dials scaled in meters.

On the other hand, bands in the more-recently exploited part of the spectrum usually are referred to by the frequencies used. An exception to that is in the portion used by radar, and for terrestrial-microwave and satellite communications, where terms such as C-band, Ku-band, K-band, X-band, and the like abound. To confuse matters, those designations have nothing to do with either frequency or wavelength.

**Starting at the bottom**

The RF spectrum runs from 10,000 Hz (10 kHz) up beyond 300 gigahertz ( $300 \times 10^9$  Hz). The lower limit is within the realm of sound; the upper limit borders on infrared light.

At the very bottom of the RF spectrum are frequencies of tens or hundreds of kilohertz, with corresponding wavelengths of thousands of meters (at 100 kHz an electromagnetic wave has a wavelength

of three kilometers, or about 1.8 miles). There, the ground-wave phenomenon predominates; radio waves tend to hug the earth rather than bounce off the ionosphere as they do at higher frequencies. That low-frequency region used to be the domain of the early radio pioneers.

The selection of those frequencies was not made freely; the mechanical spark-gap communications sets used by Marconi and others were not capable of generating higher frequencies.

With the spark-gap age long behind us, those lowest frequencies are now used primarily for navigational purposes and for long-range military communications with submarines (although in general water is a poor propagation medium, best results are achieved at lower frequencies). Low and very low frequencies are not used widely for communications because of the problems encountered when attempting to use those frequencies to convey even moderately complex data. Remember, as the frequency of the modulating information increases, so does the bandwidth of the resulting signal. The problem is similar to that encountered when trying to transmit computer data over standard telephone

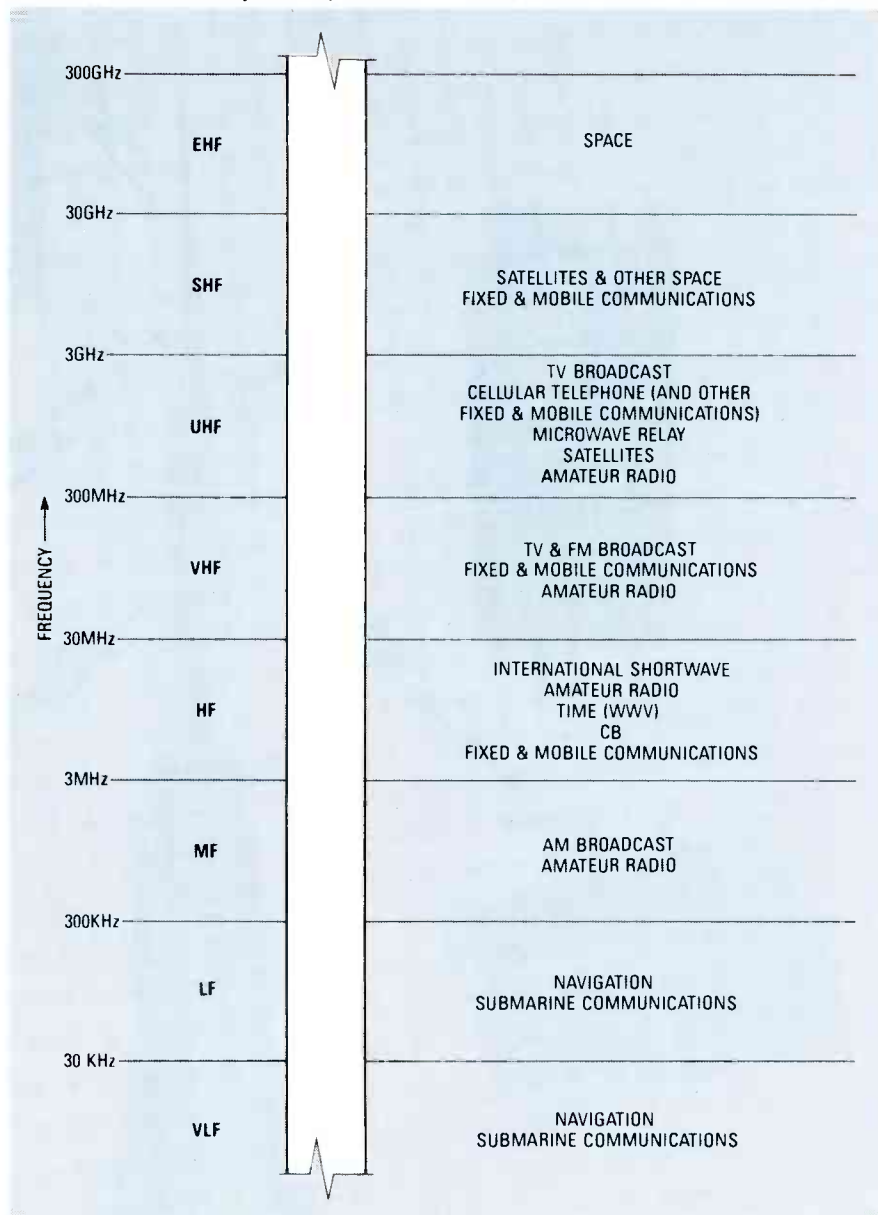

THE RF SPECTRUM extends from 10 kHz, which is within the realm of sound, to 300 gigahertz, which borders on infrared light.



circuits. Beyond a certain speed of transfer, the bandwidth of the signal exceeds the capability of the telephone lines. At low and very-low frequencies, it doesn't take much modulation to eat up vast stretches of the spectrum. And even low-frequency earth-hugging navigational beacons are being supplanted by newer satellite-based systems.

### Medium waves

The MW (Medium Wave) region stretches from 300 kHz to 3 MHz. The best known part of that region, at least to most of us, is the AM broadcast band. It occupies the frequencies from approximately 540 to 1600 kHz.

At MW frequencies an interesting phenomenon begins to occur. That is, the ground-wave propagation of the low frequencies begins to give way to sky-wave propagation. See Fig. 2. In sky-wave propagation, signals no longer follow the contours of the earth. Instead they travel a line-of-sight path to the horizon, and out into space. Part of the signal may be reflected back to earth by the ionosphere, a region of the atmosphere made up of charged particles. The amount of reflection depends on several factors, but primarily on the frequency of the transmission and the state of the ionosphere itself. The state of the ionosphere changes depending on the time of day (during the daylight hours the sun is bombarding the atmosphere with energy that can cause ionization; at night, the amount of ionization decreases) and the state of solar activity (solar flares and the like can also pour tremendous amounts of energy into the atmosphere). Anyone who has listened to an AM broadcast radio has heard the effects of the changing state of the ionosphere. During the day, reception is limited pretty much to local stations, but after the sun has set stations from hundreds or even thousands of miles away can be heard.

### Short waves

The boundaries between the segments of the RF spectrum are not clearly defined, but somewhere around 200 kHz (150 meters) we find the beginning of the shortwave region of the spectrum. That region extends to beyond 30 MHz (10 meters). The band between 3 and 30 MHz is also known as the HF (High Frequency) region. At those frequencies, the reflective properties of the ionosphere are the strongest.

Until the advent of the communications satellite, all long-distance radio communications took place on the shortwave bands, and those bands are still full of activity: not everyone, after all, can afford a satellite earth station.

Note that we are still in the pre-World-War-II part of the spectrum, and thus we most often speak in terms of wavelengths

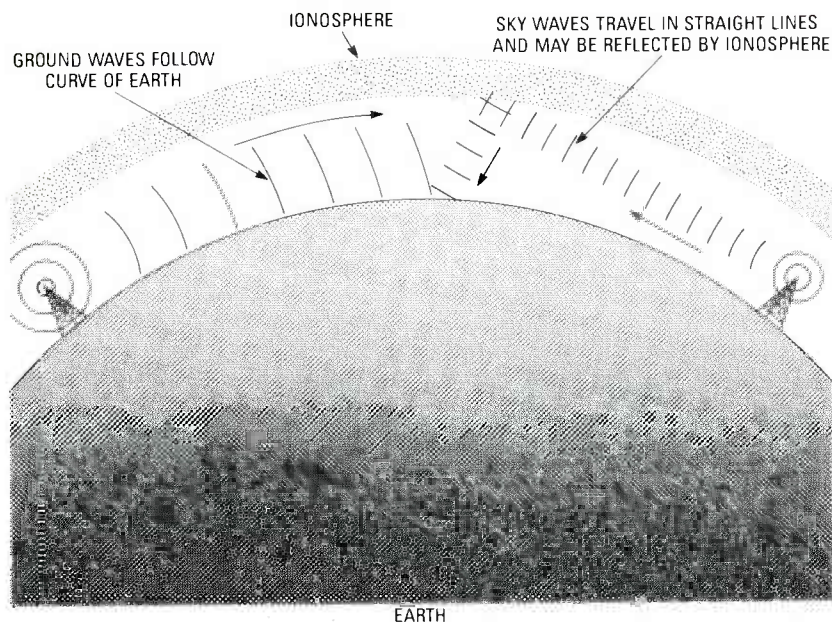

FIG. 2—GROUND WAVES, usually associated with low frequencies, hug the earth. Sky waves resulting from higher-frequency sources travel in straight lines. Depending on their frequency, and on other conditions, the waves may either travel out into space, or be reflected back to earth by the ionosphere.

rather than frequencies. Thus SWLs (Short Wave Listeners) refer to international broadcasts in the 25-, 31-, or 49-meter bands, and amateur radio operators work the 80-, 20-, or 15-meter bands.

The characteristics of the shortwave bands change as they increase in frequency. In the lower reaches of the shortwave portion of the spectrum, propagation is primarily ground wave during the day and sky wave during the evening, much like the AM broadcast band that is located not far below in frequency. Around 30 meters (10 MHz) or so, things begin to turn around and there is good long-distance sky-wave propagation during the day, but the bands shut down at night as there is only short range ground-wave communication.

Propagation on the shortwave bands varies not only with the time of day, but also with the 11-year sunspot cycle. Over a period of 11 years, the degree of sunspot activity rises to a peak, and then falls off considerably. No one is quite sure exactly why that happens, but when sunspot activity is low, as it is now, the higher frequencies become useless for long-distance communications. There simply is no skip. As sunspot activity gradually increases, the ionosphere is restored, and long-distance communications again become possible on the higher shortwave frequencies. The next peak in the sunspot cycle is expected around 1991.

International broadcast services, usually operated by the government of one country or another, abound in the shortwave bands. Sometimes they carry programming for citizens or subjects of those countries to keep them abreast of developments at home. Frequently too, those services are used to disseminate political

propaganda—sometimes subtle, and sometimes not so subtle; two such services are Radio Moscow and the Voice of America. Broadcasts from those international services go on 24 hours a day, changing frequencies and transmitter sites to obtain the best propagation conditions to various parts of the world.

Many amateur radio operators, or hams as they are frequently called, make extensive use of shortwave frequencies to talk to other hams around the country and around the world. Frequently, there are contests, with elaborate rules for scoring, in which hams accumulate points for contacting as many stations as they can—the farther away and the harder to find, the better—in a given period.

(An aside in the interest of amateur radio: The primary purpose of that "hobby"—some would call it a way of life—is to engage in two-way communications with other hams. If you just listen—whether it's with a communications receiver or with a VHF or UHF scanner—you're an SWL. When the news services reported last year that "any ham with the proper equipment could have listened in on the president's unscrambled conversations from Air Force One," they should have said, "any listener . . ." Eavesdropping is not the intent of the amateur radio service.)

There's a lot more on the shortwave bands. Although there has been a shift to satellites, with their greater reliability, many commercial services still depend on those bands. Time services, such as WWV, are found at several places on the HF bands, transmitting accurate time and other information around the clock. Much international news and weather information is sent on the shortwave bands by

radioteletype (that “jingle-jingle” sound you hear often on the shortwave bands). Many governments maintain contact with their embassies or consulates abroad by shortwave, and the astute observer can spot their “antenna farms” atop buildings in major cities.

Another shortwave service, familiar to just about all, is the Citizens’ Band (CB) service located at around 27 MHz, the old 11-meter ham band. While it’s too late to do anything about it at this late date (about 30 years too late), 27 MHz was not a wise place to locate CB. That service was intended for short-range, local use but, as many a CB-er and ham can tell you, when conditions are right there is no better place in shortwave for catching the ionospheric “skip” and talking to stations all over the world, even with just a few watts of output power. (Skip is ham and SWL slang for long-distance sky-wave communications). There is talk of opening up a citizens’ band around 900 MHz, and that would make a lot more sense, as well as for shorter antennas! (For another view see “The New World of Communications,” which immediately follows this story.)

### Very high frequencies

Once above 30 MHz or so, we enter the Very High Frequency (VHF) realm. Because that portion of the spectrum, as well as the portions above it, were not exploited until after World War II, signals there are generally specified in terms of frequency rather than wavelength. (Exceptions to that are the six- and two-meter amateur bands.) Except at the very bottom of the VHF region, propagation by skip is rare, and all communications are line-of-sight, or about as far as the horizon, depending on the height of the transmitting and receiving antennas. Maximum ranges of 50 to 60 miles are typical.

Here are found the FM broadcast band, the VHF (naturally) television channels, all sorts of local mobile-communications services (including police and fire departments, mobile telephones, business communications such as taxis and local truckers, airplane-to-airport communications, and many government and military services). Because the communications range is only line-of-sight, those frequencies are ideal for local services and can be reused time and again at fairly short geographic intervals.

The assignment of the frequencies used for television broadcasting is interesting—there are two VHF-TV bands. The lower one starts at 54 MHz for Channel 2; there used to be a Channel 1 but it disappeared a long time ago (For more information see “Whatever Happened to Channel 1” in the March 1982 issue of **Radio-Electronics**). That band continues up to 88 MHz, the top of Channel 6. There is then a gap of 86 MHz, which is used by

the FM broadcast service (between 88 and 108 MHz), among others. The VHF-TV channels begin again at 174 MHz (Channel 7) and continue to 216 MHz, which is the top of Channel 13, the last VHF channel. That gap between the upper and lower VHF-TV bands explains why, if you live in a fringe area, Channel 7 or 8 may be more difficult to receive than Channel 5 or 6. At higher frequencies it is more difficult (and more expensive) to build sensitive receiving equipment, and the efficiency of old antennas and feedlines falls off.

Almost all of us have witnessed the “venetian blind” effect on our TV sets. It is caused by VHF skip, which usually takes place in the spring and fall. The effect is caused by the reception of two TV stations on the same channel. One station is your local one, while the other might be located hundreds of miles away. The horizontal bars that give the venetian-blind effect its nickname are the result of the two signals interfering with one another. If the bars seem to move up or down the screen, it’s because the horizontal-sync frequencies of the two stations aren’t exactly the same. It takes just a fraction of a percent of difference at 15,734 kHz (the standard horizontal-sync frequency) to be noticeable. That type of interference is analogous to beat notes at audio frequencies or diffraction patterns in light.

Many people have the impression that it is the nature of FM that limits the range of broadcasts made using that type of modulation. That is simply not true! The reason for the limited range of FM broadcasts is that the frequencies assigned to that service are restricted to line-of-sight propagation. Frequency modulation is actually far superior to AM—not only in resistance to atmospheric noise, but in resistance to other types of interference, as well as in resistance to fading. It’s just that by the time the usefulness of FM was recognized, the lower frequencies were all occupied. Perhaps that’s just as well—the 20-MHz spread of the FM broadcast band allows for plenty of wideband stations transmitting high-quality audio.

### Ultra high frequencies

Starting at about 300 MHz and extending to about 3,000 MHz is the UHF (Ultra High Frequency) band, perhaps best known because of the TV channels found there between 470 and 890 MHz. Until the late 1950’s, those frequencies were hardly used at all because the cost of building transmitting and receiving equipment for that part of the spectrum was just too high. In fact, until just a few decades ago, virtually all the frequencies in that band and the ones higher in frequency were part of the FCC’s legacy to amateur radio. Amateurs, it was hoped, would learn how to tame those “esoteric” regions of the RF spectrum.

These days, UHF is pretty much an extension of the VHF band. Many of the services found on VHF also now have allocations in the UHF band. Those include the land mobile services (especially cellular telephones and pagers, which have been assigned what was formerly the top of the UHF-TV band), UHF television, and government agencies (police, fire, etc.).

Other than the fact that the VHF frequencies are just about completely occupied, UHF offers a significant advantage to those services where hand-held receivers and/or transmitters are commonplace. That is, UHF communications gear, especially the antenna (remember antenna length is dependent on wavelength), can be made much smaller.

As an aside, handheld transceivers (a transceiver is a combination transmitter/receiver) are commonly called walkie-talkies, but the proper term is “handie-talkie” (because it fits in your hand). A walkie-talkie is actually defined as a transceiver that you can carry around with you—usually strapped to your back or slung over your shoulder on a strap—to leave your hands relatively free. The term “creepie-peepie,” for a portable TV-camera/transmitter combination, never caught on (and that’s probably a good thing).

Incidentally, you can tell whether a handie-talkie is operating on VHF or UHF by its “rubber duckie” antenna. If it’s about as thick as a finger, the unit is for VHF; if it’s about the thickness of a wire, it’s for UHF.

Once we get to the UHF band, we are dealing with frequencies that begin to approach those of light. Not surprisingly, then, signals here begin to acquire some of the properties of light. One of the most common examples of that is the deterioration of UHF-TV reception during rainy weather. That happens because raindrops tend to block the radio waves, just as they do light, and fewer and fewer get through as the distance between transmitter and receiver increases.

### Super high frequencies

While the microwave band “officially” begins at about 250 MHz, the term microwave is now popularly used to describe signals in the Super High Frequency (SHF) region, above 3000 MHz. Here it is no longer convenient to refer to frequencies in terms of megahertz; instead we speak in terms of gigahertz, or billions of cycles per second. While wavelengths here are still far longer than those of light, they are also short enough to begin exhibiting many more of the properties of light. At the upper end of the SHF band, 30 GHz, wavelengths are as short as a couple of inches. Like light, microwaves travel in straight lines. They are easily reflected by even small metallic surfaces;

*continued on page 53*

BENN KOBBS\*

THE 800-MHZ BAND, REGARDED AS THE last feasible band for mobile radio, is the subject of some of the most heated controversies in the communications world. In dispute are who should have the right to transmit in that band, and even who should have the right to listen to those transmissions.

This article will describe some of the current and proposed radio services in the 800-MHz band. We'll also see how the battle for control of 800 MHz may affect the future of communications electronics.

### Cellular telephone

If you live in one of the more than 100 U.S. cities that have cellular telephone service, you may have noticed that the business pages of your local newspaper have become inundated with advertisements for cellular phones. In an effort to relieve the congestion that had plagued conventional UHF mobile-phone service for years, the FCC in 1983 opened the 825-845 and 870-890-MHz bands to cellular systems. In each market, one 20-MHz band is allocated to a "wireline" carrier affiliated with the telephone company that serves the area, while the other

20 MHz is allocated to an independent "non-wireline" carrier.

Conventional mobile-phone systems typically use a single, high-power transmission site and fewer than 20 channels to cover an area. In contrast, cellular systems operate through a network of many low-power "cell" sites and hundreds of channels. Cell sites can be identified by their towers, which typically sport peculiar, triangular antenna platforms.

As a customer engaged in a cellular call drives from the coverage area of one cell into that of another, changes in signal strength trigger an automatic hand-off of the call from one cell to the next. Ideally, at worst the user hears only a split-second gap in conversation while his mobile unit switches by remote command to the channel required by the next cell.

A typical large-city cellular carrier uses 20 or 30 cell sites, all connected via land-line (telephone line) or microwave to a

# The New World of Communications

*The battle lines have been drawn for the fight over the last frontier in personal communications. In this article we'll learn more about that fight, and the prize that hangs in the balance.*

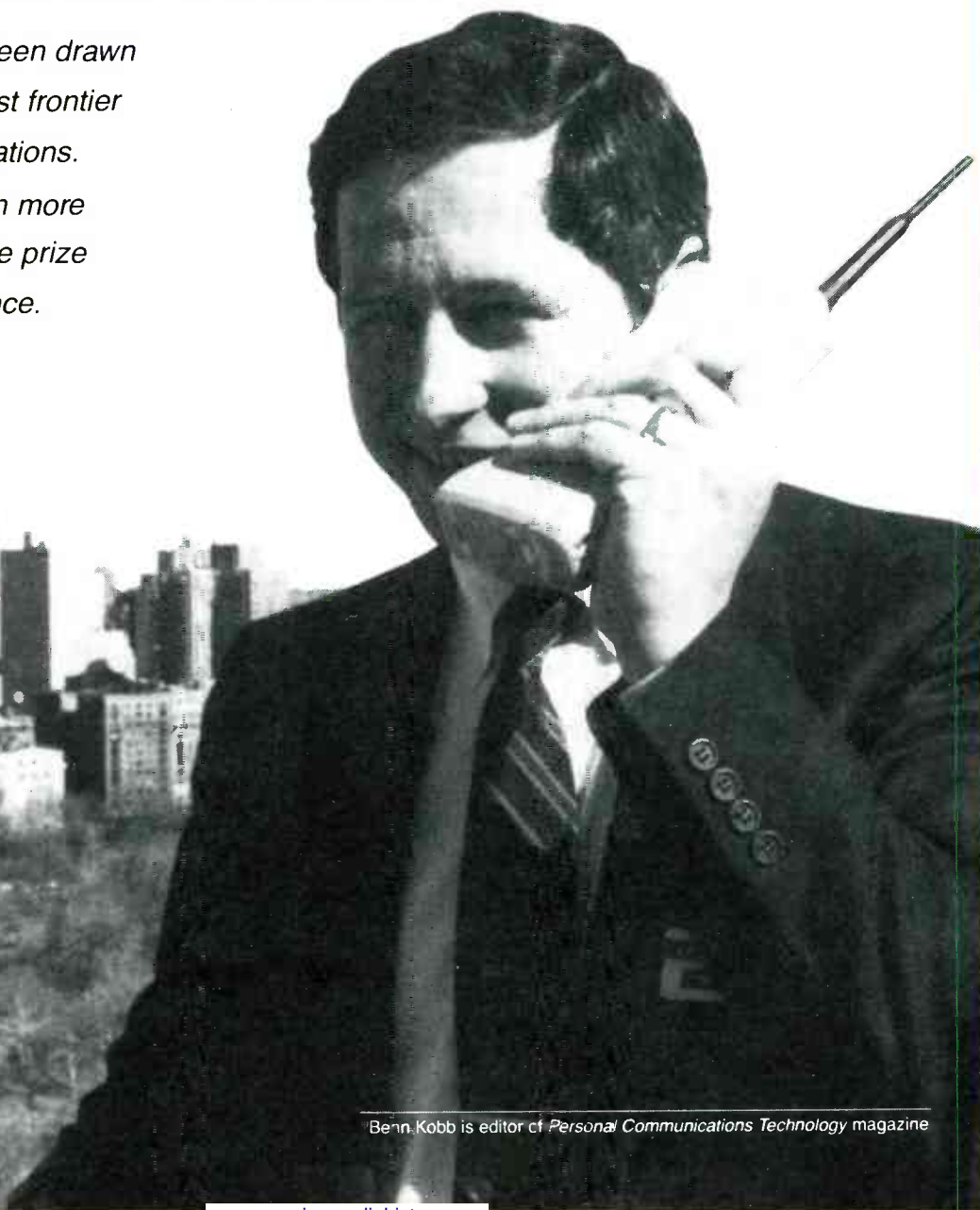

Benn Kobb is editor of *Personal Communications Technology* magazine

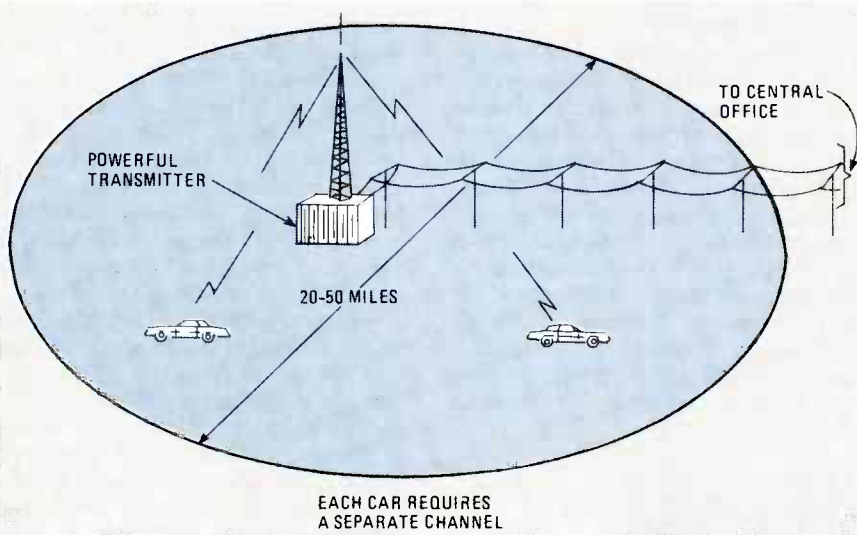

IN A CONVENTIONAL MOBILE TELEPHONE SYSTEM, only a single base station is used to cover the entire service area.

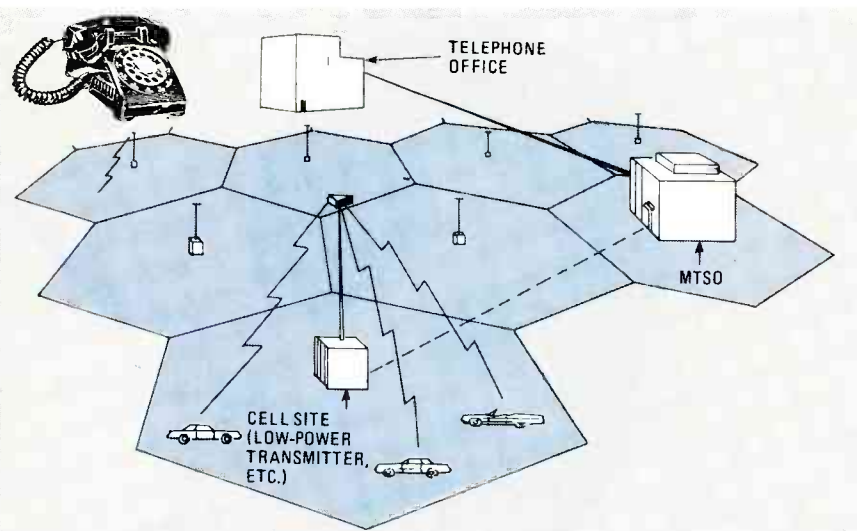

IN THE CELLULAR SYSTEM the service area is divided into smaller "cells." Each cell has its own low-power base station, called a cell site.

central Mobile Telephone Switching Office (MTSO). Essentially a telephone exchange, the MTSO transmits and receives calls between the cellular network and the public telephone-network.

Frequencies can be re-used several times within a cellular system. That feature is what gives cellular its widely-touted spectrum efficiency. Also, the cellular system has a built-in growth mechanism. If the communications traffic in a particular cell becomes too much for it to handle, the cell can be split into smaller cells, freeing additional channels to serve customers without the need to actually expand beyond the already-allocated 20 MHz.

In theory, cell-splitting was designed to help the cellular industry serve larger numbers of customers without the need for more frequencies. In practice, things have not worked out all that well. Major-

market cellular carriers have split cells to some extent, but the process is expensive. To split a cell, outlays of hundreds of thousands of dollars are required for site acquisition, engineering, and construction. Further, there have been many instances of local opposition to new tower construction. That opposition has most often been based on aesthetics or the perceived dangers of RF radiation. Because of all of that, carriers have returned to the FCC for more channels after all.

The radio spectrum, however, is a very scarce resource. Only a few megahertz remain unused at 800 MHz, and the FCC has found itself faced with many competing claims for that piece of the spectrum. After considering the claims, the Commission tentatively allocated an additional 12 MHz to the cellular service, even though it appears that the additional spectrum is only needed by a handful of car-

riers in the nation's largest cities, and that most cellular systems won't even need to use all of their existing 20 MHz.

Other countries that have cellular service are facing a similar dilemma. Should more spectrum be granted to cellular, with its analog FM technology, or should the airwaves be conserved for modulation techniques that could bring consumers exciting new services and better spectrum efficiency? Several European countries that already have FM cellular have decided to conserve parts of the radio spectrum for a futuristic project known as the Pan-European Digital Mobile Telecommunications Network.

That plan promises to bring European consumers a miniature, handheld digital communicator that could eventually replace the mobile telephone and the radio pager, and that could transmit and receive voice and text, as well as images. Tests are already underway in Sweden and Germany of competing time-domain and frequency-domain multiplexed digital-radio systems. Such systems offer greater channel capacity and flexibility than existing systems.

Will digital mobile-radio eventually take the place of analog FM in the United States? The future depends in large part on whether the FCC grants more of the spectrum for FM systems or conserves some of it for more spectrum-efficient technologies. With heavy investments in FM, substantial incentives must emerge for industry in this country to convert to digital. A successful deployment of digital radio in Europe could provide that needed incentive.

**Mobile satellite**

Cellular telephone is essentially an urban technology. That is, an expensive network of cells and switching centers is necessary to provide cellular service, and only those markets with sufficient population and business activity can profitably support cellular systems. What about the rest of the country? To serve what it viewed as a large, untapped market for mobile communications in the rural U.S., NASA in 1982 announced an ambitious proposal for a Mobile Satellite Service (MSS) to provide two-way radio, paging, mobile telephone, data, and position-location services to vehicles across the country. A very similar program is underway in Canada, where widely separated remote populations could benefit greatly from a mobile satellite.

A dozen companies agreed with the basic concept and forwarded applications to the FCC for licenses to launch mobile satellites. NASA even agreed to provide a free ride on a Space Shuttle for the winning applicant's satellite, in return for communication services. (That, of course, was before the Challenger disaster; that incident will considerably delay,

if not jeopardize, the MSS program, as well as many others.—Editor) Satellite entrepreneurs projected markets in the millions of units for vehicular, transportable, and, eventually, hand-portable satellite radios. Of course, the cost of implementing MSS will be “astronomical;” one applicant estimated its startup cost to be in the vicinity of \$700 million.

The FCC tentatively allocated 821–825 and 866–870 MHz to MSS in November, 1984. No licenses have been granted, however, because that proposed allocation is the target of intense lobbying in Washington by trade associations representing the two-way radio industry and the nation’s police, fire, and emergency-medical radio users. Those users insist that their need for additional channels far outweighs any public benefit that might come from MSS. Recent Congressional action requires the FCC to give top priority to public-safety communications in making spectrum decisions. Aspiring mobile-satellite entrepreneurs argue instead that MSS will help to fill the need for public-safety radio, and that metropolitan public-safety agencies could make more use of cellular systems to meet their communication needs.

The MSS debate has escalated beyond the public safety vs. high-tech arena, and has entered the rural vs. urban and even international arenas. Several influential congressmen have lined up firmly behind MSS as the answer to under-served rural-communication needs, while others argue just as strenuously that urban areas, facing severe spectrum shortages, need the 800-MHz band for police and fire radios.

As a way out of the 800-MHz MSS dilemma, many proponents are pushing to kick MSS upstairs to the 1.6-GHz L-band where land-mobile stations do not operate. The L-band technology, they believe, will result in lower costs for satellite radios. In fact, INMARSAT, the International MARitime SATellite Organization, has just introduced a shoebox-sized L-band mobile satellite-communicator for ships of any size—even the smallest canoe. Expected to cost well under \$5000, the unit sends and receives error-free alphanumeric messages through the INMARSAT satellite system anywhere in the world.

Canada, with its substantial commitment to an 800-MHz MSS, is having to reevaluate its frequency selection. If the U.S. moves ahead with an 800-MHz MSS, the two nations’ systems will be compatible, each picking-up the other in the event of a malfunction. On the other hand, should the U.S. use the 800-MHz band instead for regular police and fire radios, the Canadian satellite could easily interfere with and receive interference from U.S. users. The FCC has given Canada and international telecommunications authorities official notice that the U.S. desires to use the L-band for MSS.

### Radio-determination satellite

A parallel development to MSS is the Radio-Determination Satellite Service (RDSS) recently approved by the FCC. Originally proposed by physicist-pilot-science writer Gerard O’Neill as a navigation aid for aircraft, the RDSS service would pinpoint the location of any user in an instant and enable the user to send and receive short alphanumeric messages via satellite from a palm-sized device expected to cost around \$500.

Although marine-, aviation-, and land-transportation interests are seen as major customers for RDSS, O’Neill’s company, Geostar Corp. of Princeton, NJ, envisioned the system being used also by pedestrians who could signal for help if they witnessed a crime, accident, or other emergency. Geostar weathered lengthy legal and technical battles at the FCC in order to have the RDSS service approved. The Commission concluded that there is a need for RDSS, and allocated spectrum to it in the 1610–1626.5-, 2483–2500-, and 5117–5183-MHz bands. The next step is for Geostar and several other prospective RDSS companies to complete their funding and begin construction and launch of the satellites. How much money will they have to raise? The business plans submitted to the FCC indicate an average required investment of \$300 million to start commercial RDSS operation.

### Communications privacy

If you’re a radio amateur, shortwave listener, or scanner enthusiast, chances are you’ve heard of the Electronic Communications Privacy Act (ECPA), a bill pending before the House and the Senate that could have a dramatic impact on hobby radio listening if enacted into law. Where did the ECPA come from and how will it affect radio communications?

Essentially, the ECPA is an attempt by concerned congressmen to bring federal wiretap laws up to date to accommodate new technology, especially electronic mail and mobile-telephone systems. As you may know, existing provisions of the Communications Act of 1934, as amended, prohibit the divulging or misuse of any information you may obtain by monitoring a communication not intended for you. It is that feature of existing law that permits SWL’s and scanner listeners to engage in their hobby without fear of criminal prosecution—as long as they don’t divulge what they hear or use the information for personal gain or criminal purposes.

The emergence of computer crime, of satellite-TVRO technology, and of cellular-telephone systems have led various trade associations to lobby congressmen to support legislation that would have a broad application to penalize illegal interception of any electronic communication—whether transmitted by wire, fiber

optics, cellular, satellite, or a not-yet-invented communications system. Accordingly, two similar bills were introduced providing stiff penalties for unauthorized interception of communications. Those bills are aimed not at amending the Communications Act, but at the wiretap provisions of the Omnibus Crime Control and Safe Streets Act.

The sponsoring trade associations, including the Cellular Telecommunications Industry Association, the Electronic Mail Association, and others, were generally satisfied with the wording of the proposed legislation which would, it appeared, protect their constituencies from invasion of privacy.

Radio-hobby organizations, however, were aghast at the sometimes draconian—and other times just plain confusing—wording of the bills. For example, the ECPA initially would have made it illegal to listen to a signal emitted by a radio in a vehicle but gave the green light to listening to a hand-held radio. Fortunately, that portion was later removed. The status of amateur-radio “autopatch” or telephone interconnection was extremely vague; although the bills “exempted” amateur radio from their privacy protections, they did make it illegal to listen to telephone calls. That issue is still unclear in the current version of the bills, although most observers interpret the language to mean that you won’t be criminally liable for listening in on a ham’s autopatch call.



**UNDER SOME PROVISIONS** of the ECPA, if passed, the legal use of scanners and other communications gear would be curtailed.

The bills appeared to make listening to marine, aviation, or governmental stations illegal, too. After lengthy hearings that included testimony from the American Radio Relay League (ARRL) and the Association of North American Radio Clubs (ANARC), changes were introduced in the legislation to make it at least somewhat more palatable to radio hobbyists and amateurs.

The current version of the House bill, HR 3378, permits monitoring of most of the radio services you might hear on a scanner or shortwave receiver—as long as those services are not scrambled or encrypted. Unfortunately, the mere reception of a scrambled radio signal—even if

you do not unscramble or demodulate the signal—will carry criminal penalties, at least under the current version. Unauthorized reception of a cellular telephone conversation could result in a fine of up to \$500 and up to six months in jail. That provision was adopted even though cellular telephones can be received on 800-MHz scanners, service monitors, spectrum analyzers, and on many TV sets and videocassette recorders when they are tuned above Channel 80. If you recall, in the 1970's the FCC reappropriated the frequencies for the little-used UHF Channels 70 through 83 and reassigned them to mobile-communications services. Part of that allocation went to cellular telephone.

Monitoring of other common-carrier communications, such as microwave radio, paging, or international marine-radiotelephone services, would carry stiffer penalties. However, listening to cordless telephones would be exempt from any criminal sanctions.

How those proposed laws would affect satellite-TVRO owners is anything but clear at this point. Legislators involved in the ECPA have publicly conceded that they don't want the bills to have any effect one way or the other on satellite-TVRO owners, even though monitoring of satellites is specifically prohibited by the legislation unless the material received is intended for use by television broadcast-stations.

The final legislation, if adopted by Congress and signed by the President, could of course end up being more, or less, restrictive than HR 3378. Watch the What's News, Satellite News, and Video News columns in **Radio-Electronics** for any late-breaking information on the ECPA. Hopefully, you won't have to retire your communications receiver and take up butterfly collecting.

### Personal radio

The Citizens Band (CB) radio service operates at 27 MHz. However, the original "Citizens Radio Service" occupied the entire band between 460–470 MHz when it was created in the 1940's. The FCC eventually took most of the UHF band from Citizens Radio and reallocated the frequencies to business and industrial radio-services, turning the old 11-meter ham band over to CB as a sort of compensation for the loss.

A sliver of that 460-MHz band—eight channels—still exists for citizens radio (now called "personal" radio) at UHF, and it is in that band that the "CB of the future" may find a home.

To understand what may happen to the UHF band, and how its fate is tied to the 800-MHz proceedings, it's necessary to backtrack to 1975 when the CB boom was hitting its peak. Millions of Americans were installing CB's in homes and cars, and legitimate users were being crowded



**DURING THE CB BOOM** of the mid 1970's millions of Americans were installing CB gear, such as the unit shown here, in their cars and homes.

out by those "experimenting" with skip and using illegal amplifiers. The FCC was experiencing one of the biggest headaches in its history: A runaway radio service that was impossible to control and license effectively.

The commission at that time received several proposals to initiate a new CB-radio service at 220 MHz in order to take some of the pressure off of the 27-MHz band. The 220-MHz band was the domain of amateur-radio operators, and they strongly objected to that reallocation, predicting that the result would be even more on-the-air chaos.

Hams were successful in keeping 220 MHz. The FCC's eyes turned to establishing the new CB service at 800 MHz, and in 1979 the agency began a large-scale inquiry into how that could be accomplished. Consultants were hired. Thousands of questionnaires were distributed. Comments were received from industry and the public.

In 1983, the General Electric company filed a request with the FCC to expedite the process of authorizing a new service at 800 MHz. It reported the results of its program to develop what it called a *Personal Radio Communications Service* (PRCS), a highly advanced base- and mobile-radio system for the family or small business user. The projected cost for both the base and the mobile unit was under \$500. That FM system used selective addressing and microprocessor-controlled channel selection to assure users of a free channel and to reduce interference to the maximum extent possible.

PRCS was a flexible system that would have lent itself well to travelers-assistance and motorist-safety applications. PRCS had, however, one particular capability that represented both its most exciting feature and its downfall. PRCS could be used as a mobile telephone. The user could make telephone calls from a mobile or portable unit, through one's own base station at home, connected to the telephone line in a similar manner as an answering

machine. No special charges would apply, unless the user chose to operate through an optional local-repeater system for greater range. Repeater fees were expected to be about \$10 a month.

The competition PRCS could have given to the then-infant cellular-telephone industry was considerable. Unlike cellular, PRCS was capable of direct mobile-to-mobile communication and through-the-home mobile-telephone calling at no cost. Attorneys for General Electric's competitors are unwilling to sacrifice any of the precious 800-MHz spectrum to a consumer-oriented personal-radio service. So they filed mountains of documents with the FCC claiming that PRCS would be beset by massive interference and that there was little or no measurable demand for the service anyway, even though GE was attracting interest as a result of PRCS demonstrations.

Faced with competing demands for 800-MHz, and contending that the higher-priced cellular telephone could meet most of the needs projected for the PRCS, the FCC elected not to authorize PRCS and to let the experimental authorizations for the small number of existing PRCS stations expire. A petition for reconsideration of that action, filed by the Personal Radio Steering Group Inc. of Ann Arbor, MI, is still pending.

The FCC did not forget about the promise of personal radio and the possibility of creating some kind of improvement in CB. In January of this year, the Commission returned to those 8 460-MHz channels that belonged to the Citizens Radio of old, now called the *General Mobile Radio Service* (GMRS), and proposed to establish in those channels a *CB Consumer Radio Service* based on low-power hand-held radios.

That proposal was greeted with astonishment by a large user of the GMRS channels, REACT, the national association of volunteer emergency-communications teams, and by many non-affiliated personal-radio users and community-

watch groups. Those users have operated GMRS repeater systems for years and did not take kindly to the FCC's recommendation that the Consumer Radio Service be limited to short-range, unlicensed walkie-talkies. GMRS licensees are busy with a campaign to alert their congress-



THIS MIDLAND 70-526 mobile UHF transceiver is designed for GMRS use.

sional representatives to the take-away that the Consumer Radio Service seems to represent. The FCC maintains that it's keeping an open mind on the subject and won't do anything with the GMRS channels until all of the formal comments are received (the deadline for that was this

past June 30) and it has had a chance to analyze them.

**Flexible radio service**

So far, there is still one part of the 800-MHz band that remains unallocated. We've looked at some of the radio services proposed for this band, including one (PRCS) that appears to have been ruled out. The lucky radio service or services that receive an 800-MHz allocation will undoubtedly start a new industry or enhance an existing one, depending on how the allocations are made. Has the FCC given any indication as to what it will do?

Several Commissioners and staff members have indicated that they would like to try a totally different approach to spectrum allocation. Instead of weighing the arguments presented by petitioners and granting the requests they determine are most in the public interest, the FCC is examining the possibility of throwing the remaining portion of the 800-MHz band wide-open for any lawful use by selected licensees.

That would be accomplished by a lottery or auction process to award a limited number of nationwide licenses to parties who in turn would decide for themselves which service—mobile radio, cellular telephone, paging, satellite, video, etc.—would be most profitable. They could then implement their spectrum allocation.

That would relieve the commission of the difficult task of deciding which proposed communication services are most beneficial to the public, and would leave the future of the spectrum in the hands of the marketplace.

That proposal, known generally as the Flexible Allocation or Flexible Radio Service, has produced heated debate from within and outside the FCC. The approach could result in the necessity for two-way radio users to buy their channels instead of receiving them "free" with an FCC license.

Such a Flexible Radio Service could, theoretically at least, bring new communications technologies to market faster because detailed FCC approval at every step along the way would not be needed. Proponents of flexible allocation say it is our last chance to try something innovative with the radio spectrum. Opponents of the controversial proposal say it is wrong to conduct economic experiments with precious frequencies needed for public services.

Millions, if not billions of dollars hang in the balance of those critical decisions about how the radio spectrum should best be allocated. The UHF band—particularly 800 MHz—will be the cause of quite a few interesting battles over the future of communications. Who do *you* believe should win the "Spectrum Wars?" **R-E**

**FROM DC TO MICROWAVE**

*continued from page 48*

that property is what makes things like radar (which is an acronym for *R*ADIO *D*etection *A*nd *R*anging), used for tracking airplanes as well as speeding motorists, possible.

Microwave is used for communications in areas where it is impractical to lay or string cables. Microwave receivers and transmitters located atop high towers in rural areas, or on tall buildings in cities, relay communications over spans of dozens of miles at a time. Much transcontinental voice and data communications, once handled by cable, is now accomplished via microwave links.

The frequencies used by communications satellites are also located in the SHF part of the spectrum. Because, with their relatively short wavelengths, microwaves act like light, they can be treated like light. The familiar satellite dish (see Fig. 3) is actually the radio equivalent of a reflecting telescope. The purpose of the dish in a receiving installation is to collect the microwave signals coming from a satellite transponder and focus them on an antenna (called a probe) located at the dish's focal point (within a feedhorn). Similarly, in a transmitting set-up, the

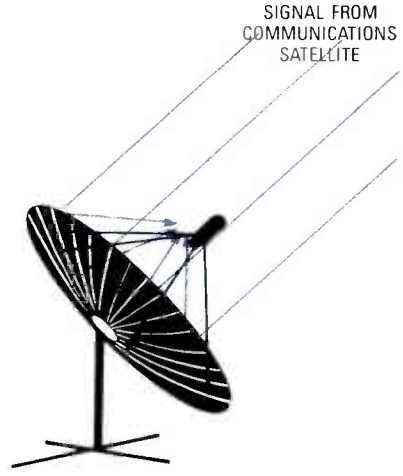

**FIG. 3—BECAUSE THEY HAVE PROPERTIES similar to those of light, microwave signals can be collected and focused on an antenna element by a metallic surfaced reflector. That property is the basis of the satellite dish. The satellite dish is the radio equivalent of the optical reflecting telescope.**

dish is used to concentrate microwave signals into a tight beam. Satellite-TV activity takes place between 3.4 and 4.2 gigahertz (the C-band) and between 11.7 and 12.7 gigahertz (the Ku-band—pronounced "cue-band").

There is some concern over the effects of microwave radiation on the human

body. Just as a microwave oven can induce heating in organic (and metallic) materials by stimulating molecular motion (the faster molecules or atoms move, the hotter they become), any microwave source can do the same. There have been reports that microwave technicians, particularly those working with high power levels, have suffered higher than normal rates of certain disorders such as cataracts. To most of us microwaves pose no health threat but nevertheless, like anything that is potentially dangerous, they should be treated with care and respect.

**And beyond**

Above the SHF band is the EHF (*E*xtrremely *H*igh *F*requency) region. Frequencies there are most conveniently specified in terahertz—thousands of billions of cycles per second. Wavelengths in the EHF region are only in the millimeter range (for reference, a dime is a little less than a millimeter thick). At the top end of the range, the frequencies border on those of infrared light. While little use is made of these frequencies at present, they are beginning to be exploited for communications in space. It is safe to expect that use of those frequencies will grow as our exploration of space continues, and as the frequencies below become occupied. **R-E**

## TV SIGNAL DESCRAMBLING

*More on PLL's and how they can be used in practical descrambling circuits.*

WILLIAM SHEETS and RUDOLF F. GRAF

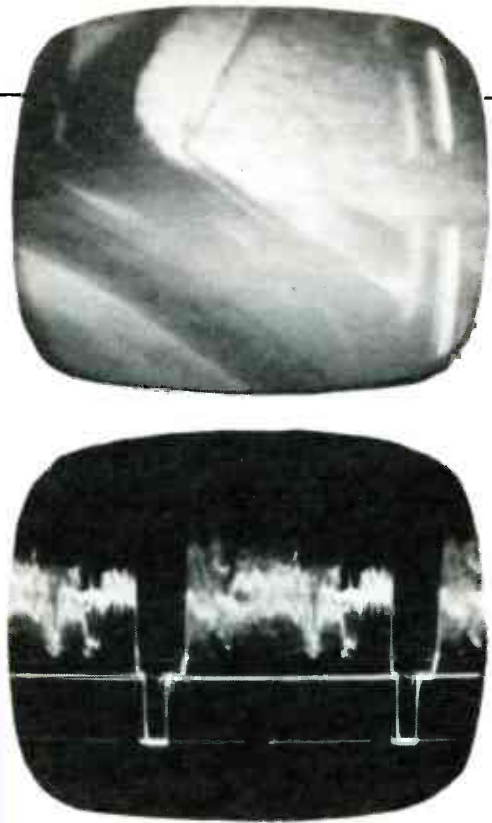

**Part 4** LAST TIME, WE looked at some practical descrambling circuits. At the heart of several of those circuits was the Phase-Locked Loop (PLL). This month, we'll begin by looking more closely at PLL's, and how they can be used to descramble various types of signals.

### Phase-locked loops

Thanks, in part, to the widespread popularity of FM stereo radio, a number of single-IC PLL FM-stereo demodulators have been developed. Generally those devices contain an input amplifier, a phase detector, a VCO (Voltage Controlled Oscillator), some form of lock detector for audio muting or stereo lamp switching, a decoder matrix, and a voltage regulator that allows the unit to operate from a wide variety of supply voltages. Some of those devices require little in the way of external components, including hard-to-find coils, to operate.

PLL's are ideal for regenerating the 15-, 31-, 40-, or 62-kHz subcarriers used in the gated-sync, sinewave, or SSAVI systems that we have discussed previously. Where appropriate, PLL's can also be used to demodulate hidden audio subcarriers, thus doing two jobs for the price of one. Further, because PLL's are mass produced, they are easily obtained and inexpensive.

Figure 1 is a block diagram of a typical PLL. Basically, a PLL operates by comparing the frequency of an input signal with that of a signal generated by an on-board VCO. The VCO is set up to shift frequency such that its output frequency and that of the PLL's input signal are identical. Both signals are applied to a phase detector, which is where the actual comparison takes place. (In some instances the VCO is set up to operate at a multiple of the input frequency range. In PLL's where that is done, a frequency divider is inserted in the loop between the VCO and

Over the next few months, **Radio-Electronics** will be presenting a series of articles describing the techniques used by pay-TV and cable companies to scramble their signals. While specific circuits for specific scrambling systems will be discussed, they are presented for *informational and experimental purposes only*. Therefore, parts lists, parts suppliers, and additional technical support will *not be available* for those circuits.

the phase detector.) If the frequencies of the input and the VCO signals differ, the phase detector produces an AC signal. Otherwise, a DC voltage that is proportional to the *phase* difference between the two signals is produced. Thus, once the PLL is "locked," that is, once the input and VCO frequencies match, only a phase error exists between the two signals. The frequencies of the input and output signals are equal. The output of the phase detector is fed to an amplifier/integrator. That stage produces the control voltage for the VCO.

recovering only one mono channel. Therefore, only one of the audio outputs is used. However, we do need to recover the pilot signal. In FM-stereo systems, the pilot is used only to indicate the presence of a stereo signal. But in some scrambling systems, such as gated pulse, that signal is needed for sync regeneration. For other scrambling systems, the pilot signal could be used to switch in the decoder automatically at the appropriate time.

The PLL used in the circuit of Fig. 2 is designed for 19/38-kHz operation. If needed, we feel that the LM1800 could be made to operate at frequencies up to 100 kHz because it's fabricated using transistors that inherently can operate to several megahertz. However, we have not

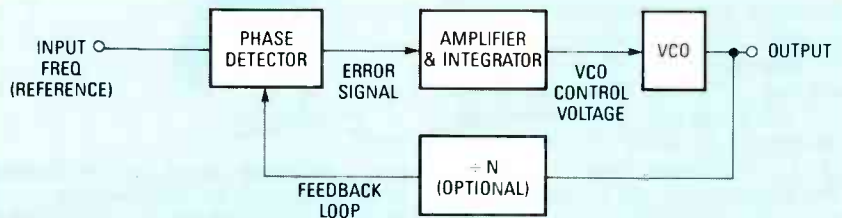

FIG. 1—A PLL IS AT THE HEART of many descrambling circuits. A block diagram of that device, commonly available in IC form, is shown here.

A circuit that can be used for subcarrier regeneration is shown in Fig. 2; the heart of the circuit is an LM1800 PLL stereo-demodulator IC. The circuit is very similar to the one that would be used for FM-stereo detection. With subcarrier-regeneration circuits, we do not have to worry about stereo separation, since we are

been able to confirm that.

In any event, the most commonly used subcarrier frequencies are within the range of the LM1800. In the gated-pulse system, where the audio is usually encrypted on a 15-kHz subcarrier, the circuit of Fig. 2 could be used both to recover the subcarrier and to decode the audio.



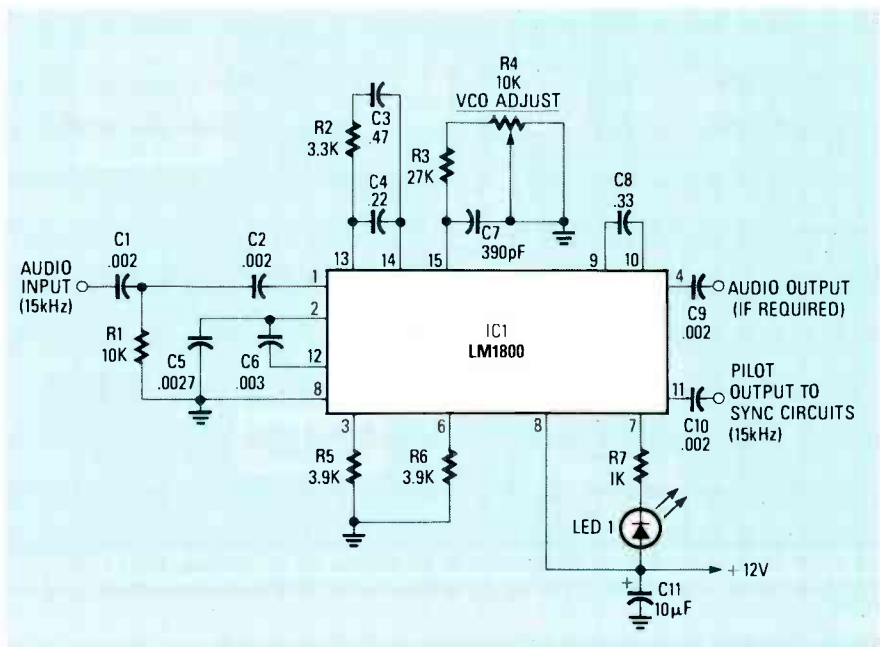

FIG. 2—THOUGH DESIGNED FOR FM-STEREO DEMODULATION, the LM1800 PLL can be used to good advantage in descrambling systems. Here that IC is used to regenerate a hidden subcarrier.

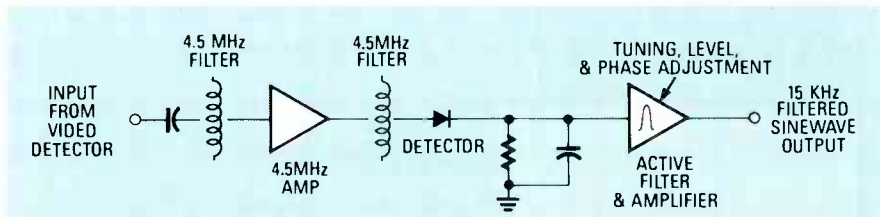

FIG. 3—THIS BLOCK DIAGRAM shows the system used to recover the descrambling sinewave required by a sinewave decoder.

In the sinewave system, the audio is placed on a 62.5-kHz subcarrier. For that scrambling system, the circuit of Fig. 2 would be used only for recovering the audio. Note that some modifications to the highpass filter at pin 1 and the VCO's frequency-control circuit at pin 15 would be necessary to accommodate the dif-

ferent frequency. The circuit as shown is designed for 15-kHz operation. In the highpass filter, C1 and C2 should both be changed to 470-pF units. In the VCO control circuit, C7 should be replaced with a 100-pF unit. Alternately, R3 and R4 could be replaced with 6.8K and 5K units, respectively. You may need to modify the

PLL loop filter and the threshold filter.

A worthwhile experiment would be to set up the circuit on a breadboard and to check out its operation using an audio or function generator to supply the needed input signal.

### Sinewave decoding

The procedure used to recover the sync in the sinewave scrambling system differs somewhat. In the sinewave system, the synchronized 15-kHz sinewave is encoded on the 4.5-MHz sound subcarrier. In a conventional TV-sound limiter, that AM component is stripped away. Therefore it does not appear at the output of the sound detector and we must obtain that signal at a different point in the signal processing trail.

Figure 3 shows a block diagram of a circuit that could be used to recover the decoding sinewave. The 4.5-MHz sound subcarrier is taken from the video detector. It could also be taken from the TV set's sound/sync detector, if the set has one (not all do), or, if possible, from the sound IF *before* limiting has taken place.

After the 4.5-MHz sound subcarrier has been obtained, it is amplified and then fed to an envelope-detector stage. The output of the detector contains the low-level 15-kHz signal (modulation percentages of 5 to 15 are typical), as well as unwanted components such as induced AM audio from the sound channel.

The unwanted components are removed by a high-Q active filter. In that stage the signal is also amplified and its phase adjusted so that it differs from the encoding signal by 180°. Finally, any distortion due to non-linearity, harmonics, etc. is removed; the recovered signal must match the encoding one exactly, except for the phase difference, or incomplete cancellation will take place. The result would be ripples, shading, etc. in the picture.

It is possible to distort the recovered signal deliberately to compensate for non-

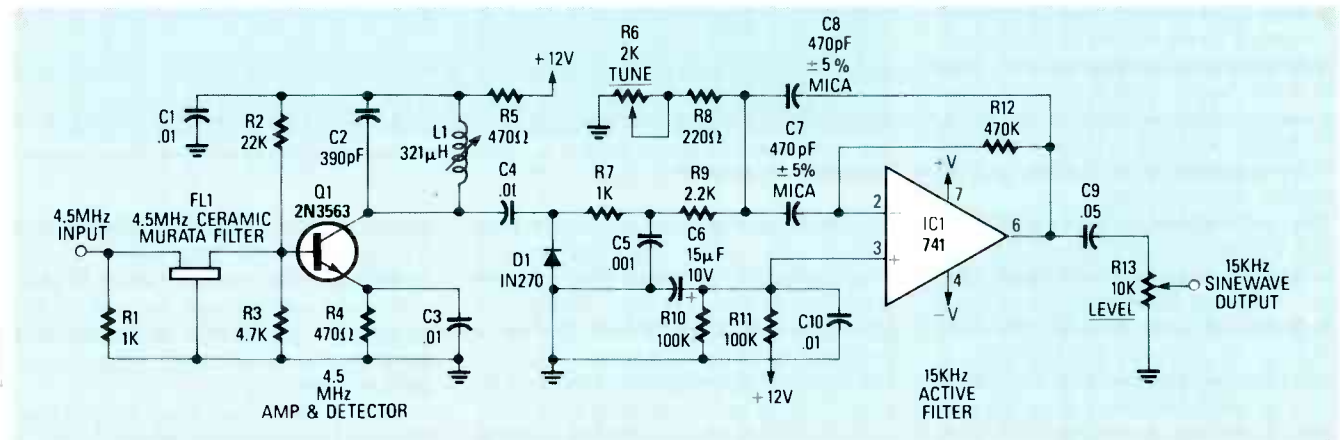

FIG. 4—HERE THE BLOCK DIAGRAM of Fig. 3 is translated into a practical circuit. Any op-amp designed for audio work may be used for IC1.

linearity elsewhere in the decoder, such as in the modulator. However the best decoders are the ones that are well designed (i.e. linear) in the first place. Generally, if the sinewave-recovery circuit requires tweaking or tailoring to match the balance of the decoder, it is an indication of a poorly designed system. A circuit that is well engineered should work the first time, and not require any critical adjustments or adjustment techniques. For the most part, the circuits that we are presenting in this series meet that criteria. If the circuit is unstable, or requires critical adjustment, it is an indication that something is wrong.

Now let's translate our block diagram into a practical circuit. One representative circuit is shown in Fig. 4. In that relatively simple circuit, the 4.5-MHz signal is taken from the TV sound system *before* limiting. It is passed through a 4.5-MHz ceramic filter to eliminate any "junk" (unwanted components), and then amplified by Q1, an NPN transistor that has a gain of 25 to 30 dB. A 4.5-MHz tuned circuit in the collector circuit of Q1 serves as a load, across which the 4.5-MHz output-signal is developed. The signal is then diode detected and fed to the active-filter stage. The filter has a nominal gain of 40 dB and is tuned to 15 kHz. In that stage the phase shift of the signal is adjusted as previously described. That adjustment is made by varying the setting of R6. The response of the active filter is much like that of a tuned LC circuit. While a 741 is specified for IC1, almost any op-amp designed for AF operation is suitable. Among the other possible choices are an RC4558, an LM1458, or a 747. The output of the circuit is taken from R13, the 10K LEVEL potentiometer.

During operation, the circuit should be checked with a scope for linearity. To be conservative, the 15-kHz signal seen at the output of the op amp should never exceed about one half the supply voltage. For example, in the circuit of Fig. 4, which is designed to use a 12-volt supply, that voltage should not exceed 6-volts p-p. The level of the 4.5-MHz input signal will be between about 30 and 100 millivolts, depending on the modulation level. Note that levels higher than that could cause limiting in either the amp or the active filter stages. That will result in a distorted 15-kHz sinewave at the output and incomplete descrambling.

The circuit shown in Fig. 4 can be combined with the circuit shown in Fig. 7 of Part 3 of this series (see the August, 1986 issue of **Radio-Electronics**) to form a functional sinewave decoder. However, installing the decoder would require at least some familiarity with how a TV set works, as several internal connections are required. Among other things, you must know where to tap off the required inputs, where to feed the descrambled output,

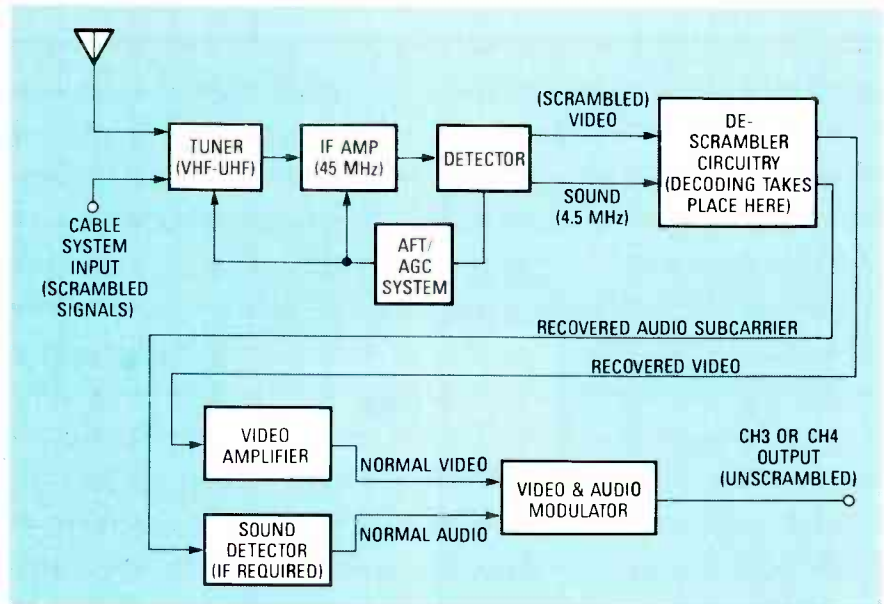

FIG. 5—TO AVOID COMPLICATED INSTALLATIONS, the decoder can be combined with a TV front-end to form a converter-descrambler. The output of that circuit can be fed directly to the antenna input on a TV set.

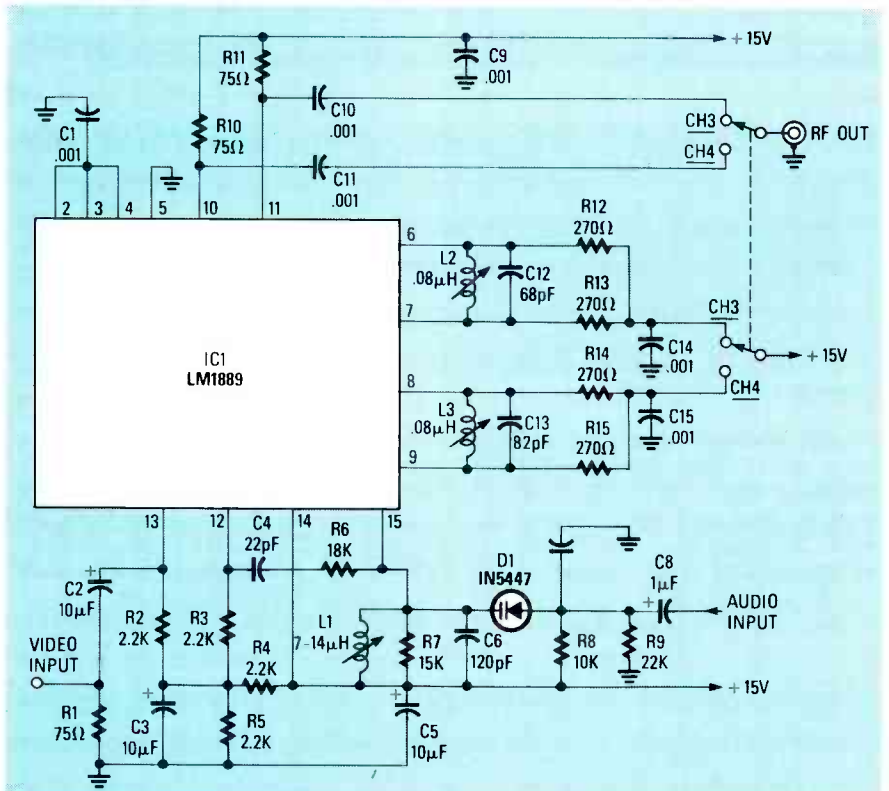

FIG. 6—A SIMPLE RF MODULATOR. If you wish, a modulator could also be obtained from a discarded videogame or computer.

and where to obtain the required supply voltages. For some, that would present little problem. But many others do not have the required expertise. Further, the growing use of IC's in TV sets presents a problem. In many IC-intensive TV sets, the required tap-off points may be contained within an IC, making them inaccessible. In that case, it would be virtually impossible to connect our decoder.

The solution to those problems is to

design a decoder that essentially contains a complete TV-set "front-end." The decoder would then contain a tuner, IF amp, video and audio detectors, and an RF modulator. The output of the decoder could then be fed to a user's TV set via the antenna input.

Such a unit would most properly be called a converter-descrambler. Its block diagram is shown in Fig. 5. In it, sig from an antenna or cable system are

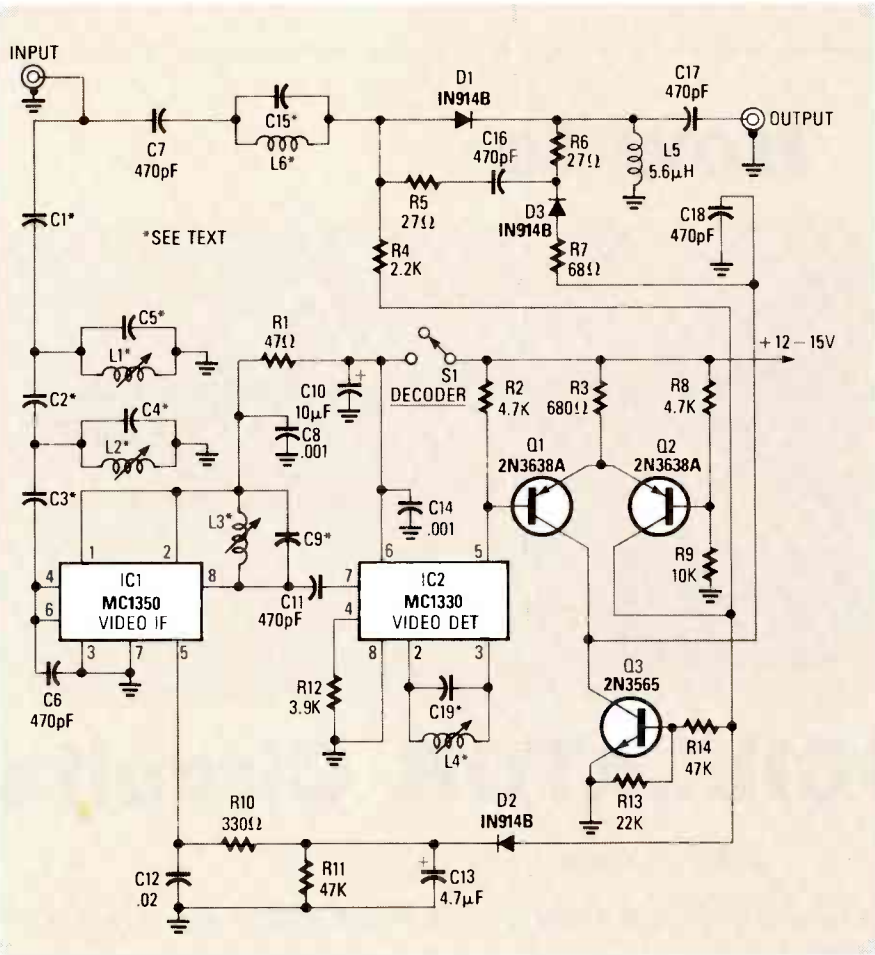

FIG. 7—IN THE OUTBAND SYSTEM, used only on cable-TV systems, the sync is hidden on an unused frequency, outside of the channel itself. Therefore, a decoder, like the one shown here, must have some way to "tune in" that out-of-channel sync signal.

a tuner and on to a 45-MHz IF amp; 45 MHz is a standard TV IF frequency. From the amp, the signal is fed to standard TV sound and video detectors. The outputs from the detectors are scrambled video and the 4.5-MHz audio subcarrier. Those are the signals that the descrambler needs to do its job. The outputs of the descrambler stage are a normal video signal and either a normal audio signal or a recovered audio subcarrier, depending on the scrambling system. In the latter case, the subcarrier is fed to a second sound detector to recover a normal audio signal. The audio and video could be fed directly to a set with audio/video inputs, but a more "universal" approach would be to feed those signals to an RF modulator set up to output on either Channel 3 or 4. A standard RF modulator circuit is shown in Fig. 6. Alternately, RF modulators are available commercially or can be salvaged from a discarded videogame or computer.

### The SSAVI system

As previously discussed, SSAVI (Suppressed Sync And Video Inversion) is one of the more sophisticated of the scrambling techniques. In that system, four modes of operation are possible. Those

are: suppressed sync and inverted video, suppressed sync and normal video, normal sync and inverted video, and normal sync and normal video (unscrambled). The system has the capability to switch between any of the four modes on a frame-to-frame basis. Therefore the scrambling method can change as often as 60 times-per-second, if desired. The sound is stripped from the audio subcarrier and placed on another subcarrier located at 39.335 kHz (2.5 times the horizontal frequency).

Further complicating the task of descrambling is the fact that no reference signal is sent with the scrambled picture. The decoder must provide its own reference. Also, the decoder must be able to detect whether or not the video is inverted. Note that the sync signal is never inverted, so the decoder circuitry must only invert the video portion of the signal, when required. The sync signal may, however, be suppressed.

How does a decoder regenerate the sync and detect when the video is inverted? In the SSAVI system, the first 26 lines of the picture are sent with normal sync pulses. A PLL can lock onto that information and supply the missing information for the rest of the frame. The re-

generated sync is used to restore normal sync, which in turn is used as a reference. The leading edge of the vertical sync pulse is used as a reference from which all operations are timed. During the 20th line, which is picked out by the decoder by using a counter circuit, information is sent as to whether the video in the frame is inverted or normal.

As you can see, the SSAVI decoder is called on to perform a number of tasks. Because of that, the circuitry is rather extensive. Fortunately, it is also rather straightforward. We will look at the details in the next installment in this series.

Note that the typical SSAVI descrambler contains much circuitry that is not involved in the descrambling process. That includes anti-theft circuitry, as well as circuitry that allows for two or more tiers of premium programming. As such circuits play no part in the descrambling process, they will not be discussed.

### Outband descramblers

Before we wrap up for this month, let's look at a system that is used in many cable systems. Called the outband system, in it the sync signal is placed on a subcarrier, but the subcarrier frequency is not within the channel. Instead, it is within an unused cable channel. The frequencies most often used are somewhere around 50 MHz (below broadcast Channel 2) or between 90 and 120 MHz (those frequencies fall in the FM-broadcast and aviation bands).

As described in a previous installment, to recover the sync the decoder requires a circuit that can "tune in" the out-of-channel carrier. A typical outband decoder is shown in Fig. 7. In that circuit, the composite cable signal is split two ways. The sync frequency is passed by an appropriately tuned input filter and fed to a video IF-amp stage. A trap, set up to be resonant at the sync-carrier frequency, prevents the sync signal from appearing at the output. From the IF amp, the sync signal is fed to a video detector. The output of the video detector (pin 5, IC2), which consists solely of sync pulses, drives a differential amplifier. The differential amp drives a voltage-controlled attenuator. When a sync pulse is not present, the output of the video detector goes negative and the current from the differential amp reverse biases D1 and forward biases D2. That "inserts" the attenuator in the circuit. When a sync pulse is present, the output of the detector goes positive. Then, D1 is forward biased while D2 is reverse biased. That removes the attenuator from the circuit.

Note that values for the components in the traps and filters have not been specified. That's because those values can vary widely, depending on the frequency of the sync channel. In a future installment we will present a more detailed version of the circuit.

R-E

## How to

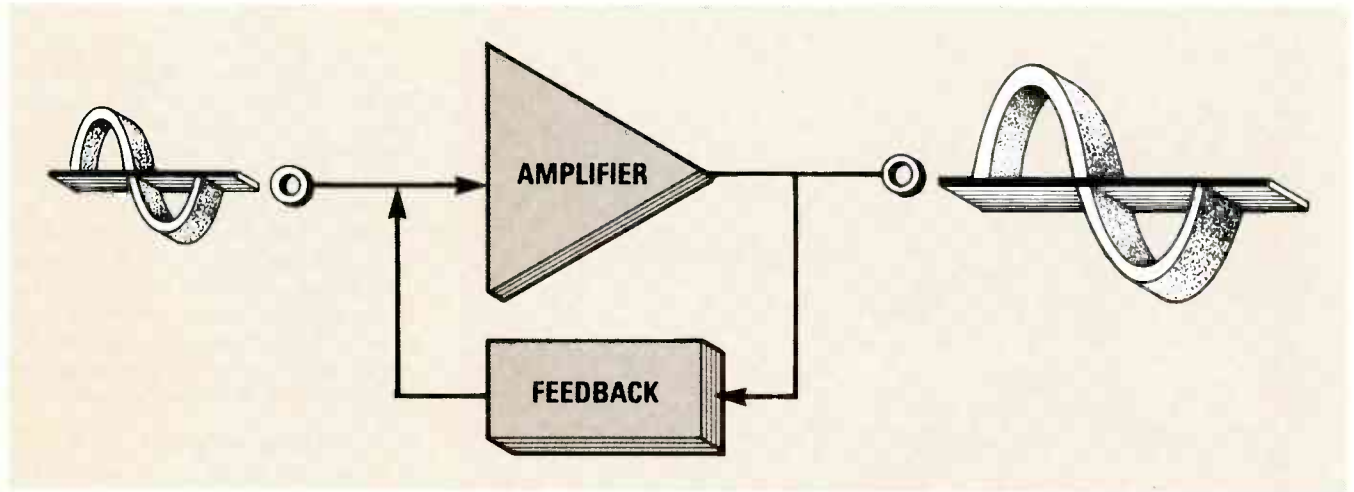

# Design OSCILLATOR Circuits

JOSEPH J. CARR

*Our series continues with a discussion of RC oscillators, ways of generating sinewaves from other waveforms, and other topics.*

**Part 3** IN THE PAST TWO INSTALLMENTS of this series we discussed relaxation oscillators and feedback oscillators built from LC tank circuits. This time we'll look at RC oscillators. Some of our example circuits are built from FET's and bipolar transistors; others are built from operational amplifiers. But whatever components they're built from, all our circuits have one thing in common: The frequency at which a given circuit oscillates is determined by one or more RC time constants in the circuit.

### The phase-shift oscillator

As we learned in a previous installment, a feedback oscillator works by feeding a portion of a circuit's output signal back to its input. The signal that is fed back must be applied in phase with the input signal. Since we usually use an inverting amplifier (which provides 180 degrees of phase shift) as the active element of a feedback oscillator, we must obtain an additional 180 degrees of phase shift from other circuit elements. In the three-leg RC phase-shift oscillator shown in Fig. 1, each leg provides 60 degrees of phase shift, for a total of 180 degrees. An op-amp version of the phase-shift oscillator is shown in Fig. 2. Both circuits produce a sinewave output signal.

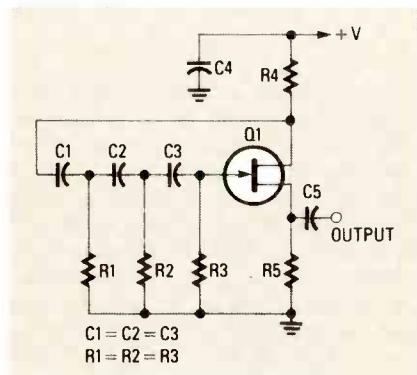

FIG. 1—EACH RC PAIR PROVIDES 60° of phase shift for a total of 180°; that phase shift combines with the 180° provided by the FET for a total of 360°.

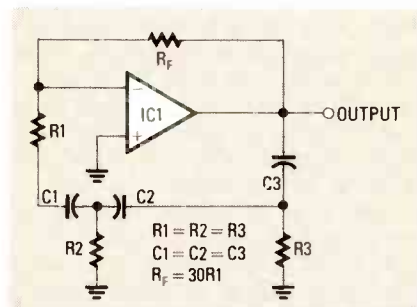

FIG. 2—A PHASE-SHIFT OSCILLATOR can also be built from an op-amp. R<sub>f</sub> must be at least 30 times the value of R<sub>1</sub> for the circuit to oscillate.

The frequency at which either circuit will oscillate is determined by the values of R<sub>1</sub>–R<sub>3</sub> and C<sub>1</sub>–C<sub>3</sub>; to keep the mathematics simple, we usually give each resistor the same value; likewise with the capacitors. In Fig. 1, the other resistors (R<sub>4</sub> and R<sub>5</sub>) serve to bias the FET, and capacitor C<sub>5</sub> provides DC isolation. We'll discuss the function of the op-amp circuit's R<sub>f</sub> below; first let's see how to calculate oscillating frequency.

Assuming that R<sub>1</sub> = R<sub>2</sub> = R<sub>3</sub> and that C<sub>1</sub> = C<sub>2</sub> = C<sub>3</sub>, then

$$f = \frac{1}{2\pi \sqrt{6} RC}$$

In that equation, R = R<sub>1</sub> and C = C<sub>1</sub>. If resistance is specified in ohms and capacitance in farads, then frequency will be given in hertz.

When the constant terms in that equation are combined, we can rewrite the equation as follows:

$$f = 1/(15.4 RC)$$

or as

$$f = 0.408 / (2\pi RC)$$

When designing an oscillator we usually need to find a resistor/capacitor combination that will produce a desired frequency, so another form of the equation can also be useful. Since there are fewer standard

capacitor values, we tend to select one and then plug it and the desired operating frequency into the equation to find the closest resistor value which will produce that frequency. So we rearrange the equation as follows:

$$R = 0.408 / (2\pi fC)$$

Let's take an example: Find the resistance required to produce a 1000-Hz oscillator with a 0.01- $\mu$ F capacitor.

$$R = \frac{0.408}{2 \times 3.14 \times 1000 \times .01 \times 10^{-6}}$$

$$R = 0.408 / (6.28 \times 10^{-5})$$

$$R = 6497 \text{ ohms}$$

In any feedback oscillator we must ensure that the closed-loop gain is unity or more. The closed-loop gain of the circuit in Fig. 2 is the ratio  $R_F/R$ . Analysis reveals that the loss in the feedback circuit is  $1/29$ , so circuit gain must be greater than 29 in order to ensure oscillation. So  $R_F$  should be at least 30 times the value of  $R$ . For the 1000-Hz oscillator discussed previously,  $R_F$  should be  $30 \times 6497 = 194,910$  ohms. You could use a 200K resistor, which is the closest standard value.

### BASIC program

To ease the tedium of calculating the values of the frequency-determining components in a phase-shift oscillator, we wrote the simple BASIC program shown in Listing 1. The program was written in the dialect of BASIC that runs on the IBM-PC, but it will run on many machines unmodified, and it should be easy to translate into another dialect.

The program calculates component values for either three-leg phase-shift oscillator presented above; in addition, it will calculate minimum and maximum resistor values for a variable-frequency oscillator. To build a variable-frequency oscillator, you would have to use a triple-gang potentiometer or a triple-pole switch to select appropriate resistors.

When you run the program, it asks whether you want to calculate values for a fixed- or a variable-frequency oscillator. You must then type in the frequency (or the frequency range) you need. Then the program will request the value of the timing capacitor. Last, it calculates and displays the resistance (or range of resistance) that will be required.

It is possible to vary the frequency of a variable-frequency phase-shift oscillator over a range greater than 10:1 using just resistors, but it is impractical to do so. Circuit considerations aside, it becomes difficult to adjust the frequency accurately. Hence the program prints a warning if you enter high and low frequencies that are in a ratio greater than 10:1. If you

### LISTING 1

```

10 GOSUB 920
20 PRINT "This program calculates
30 PRINT "the component values
40 PRINT "for an RC phase-shift
50 PRINT "oscillator.
60 PRINT
70 PRINT
80 GOSUB 960
90 GOSUB 920
100 PRINT "CHOOSE one:
110 PRINT
120 PRINT "1. Fixed oscillator
130 PRINT "2. Variable oscillator
140 PRINT
150 INPUT "SELECTION?";A
160 IF A > 2, THEN GOTO 100
170 ON A GOTO 180, 480
180 GOSUB 880
190 PRINT "Fixed Frequency
200 PRINT "option selected
210 PRINT
220 INPUT "Frequency in Hz?";F
230 PRINT
240 PRINT
250 INPUT "Capacitance in uF";C
260 C = C/(10^6)
270 R = 1/(15.391*C*F)
280 R = INT(R)
290 R4 = 30*R
300 C = C*10^6
310 GOSUB 880
320 R4 = INT(R4)
330 PRINT "Component Values for
340 PRINT "fixed frequency version
350 PRINT
360 PRINT "Operating Frequency:";
370 PRINT F;" Hz
380 PRINT "Capacitors C1=C2=C3=";
390 PRINT C;" uF
400 PRINT "Resistors R1=R2=R3=";
410 PRINT R;" Ohms
420 PRINT "Feedback Resistor R4=";
430 PRINT R4;" Ohms
440 PRINT
450 PRINT
460 GOSUB 960
470 GOTO 1150
480 GOSUB 920
490 PRINT "Variable Frequency
500 PRINT "Option Selected
510 PRINT
520 PRINT "Set upper and lower
530 PRINT "frequency limits
540 PRINT
550 INPUT "Lower Limit in Hz?";FL
560 PRINT
570 INPUT "Upper Limit in Hz?";FH
580 PRINT
590 IF FH > 11*FL THEN GOSUB 990
600 GOSUB 880
610 PRINT "Value of capacitor:
620 PRINT
630 INPUT "Capacitance in uF?";C
640 C = C/10^6
650 RL = 1/(15.391*C*FL)
660 RL = INT(RL)
670 RH = 1/(15.391*C*FH)
680 RH = INT(RH)
690 R4 = 30*RH
700 R4 = INT(R4)
710 C = C*10^6
720 GOSUB 880
730 PRINT "Component Values for
740 PRINT "Variable Frequency
750 PRINT "Oscillator
760 PRINT
770 PRINT "Frequency Range:";
780 PRINT FL;" to ";FH;" Hz
790 PRINT "Capacitors C1=C2=C3=";
800 PRINT C;" uF
810 PRINT "Resistor Range";
820 PRINT RH;" to ";RL;" Ohms
830 PRINT "Feedback Resistor R4:"
840 PRINT R4;" Ohms
850 GOSUB 880
860 GOSUB 960
870 GOTO 1150
880 FOR I = 1 TO 5
890 PRINT
900 NEXT I
910 RETURN
920 FOR I = 1 TO 30
930 PRINT
940 NEXT I
950 RETURN
960 PRINT "Press any key . . .";
970 AS=INKEY$: IF AS="" THEN 970
980 RETURN
990 GOSUB 880
1000 PRINT "Frequency range is
1010 PRINT "greater than 10:1.
1020 PRINT "It would be better
1030 PRINT "to break the range
1040 PRINT "into two bands.
1050 PRINT " You can:
1060 PRINT
1070 PRINT "1. Continue anyway
1080 PRINT " or
1090 PRINT "2. Do something else
1100 PRINT
1110 INPUT "SELECTION?";W
1120 IF W > 2, THEN GOTO 990
1130 ON W GOTO 1140,90
1140 RETURN
1150 PRINT
1160 PRINT "what's Your Pleasure?
1170 PRINT
1180 PRINT "1. Repeat
1190 PRINT "2. Start over
1200 PRINT "3. All done
1210 PRINT
1220 INPUT L
1230 IF L > 3, THEN GOTO 1150
1240 ON L GOTO 170,100,1250
1250 GOSUB 920
1260 PRINT "PROGRAM ENDED
1270 END

```

really need a wide-range variable-frequency oscillator, be patient; we'll discuss a technique for designing one below.

### Wien-bridge oscillator

Another common RC oscillator is called a Wien bridge; it is a bridge circuit that resembles a Wheatstone bridge. As you can see in Fig. 3, two arms of the Wien bridge are purely resistive, and the other two are RC networks. One of the RC networks is a series circuit, and the other is a parallel circuit. The feedback loop is

degenerative (hence stable) at all frequencies other than the oscillating frequency, which is given by:

$$f = \frac{1}{2\pi \sqrt{R3 \times R4 \times C1 \times C2}}$$

If  $R3 = R4$  and  $C1 = C2$ , then that equation can be simplified as follows:

$$f = 1/(2\pi R3 \times C1)$$

Like the phase-shift oscillator, the Wien-bridge oscillator produces a sinewave output, but its amplitude tends to be some-

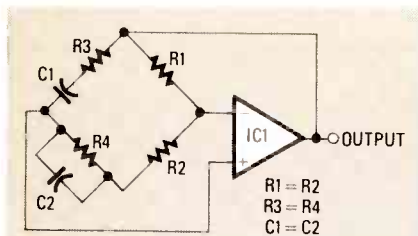

FIG. 3—A WIEN-BRIDGE OSCILLATOR resembles a Wheatstone bridge. Amplitude stability can be improved by substituting a low-current lamp for R2.

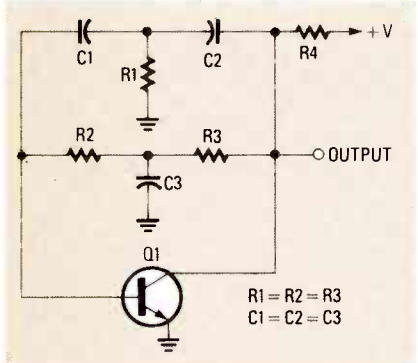

FIG. 4—TWIN-TEE OSCILLATOR is composed of two "T" shaped networks. One has series capacitors and a shunt resistor; the other has series resistors and a shunt capacitor.

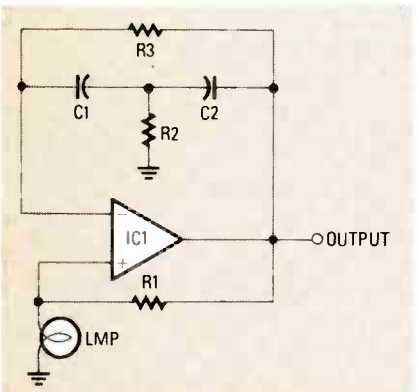

FIG. 5—THIS BRIDGED-TEE OSCILLATOR uses an incandescent lamp to increase amplitude stability of the output signal.

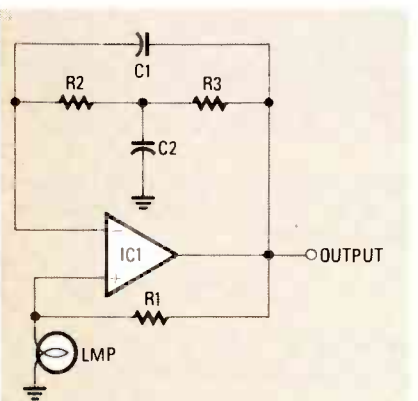

FIG. 6—ANOTHER BRIDGED-TEE OSCILLATOR; in both this circuit and the one shown in Fig. 5, the bridging component is the "opposite" of the T's series element.



FIG. 7—LOWPASS OR BANDPASS FILTERS can clean up a squarewave source and provide a pure sine wave output.

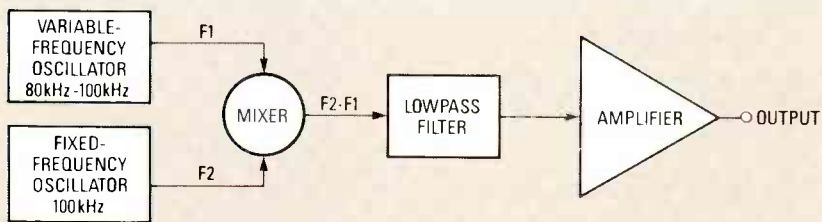

FIG. 8—A WIDE-RANGING OSCILLATOR can be built from a fixed- and a variable-frequency oscillator. Their outputs are mixed, the difference is taken, and that signal is then filtered and amplified for output.

what unstable, especially in a variable-frequency oscillator. It is possible to reduce that instability by replacing R2 with a low-current (40-mA) incandescent lamp. That type of lamp has a non-linear voltage-current characteristic that helps stabilize the output amplitude and prevent the amplifier from saturating. The lamp should be operated below incandescence.

#### Twin- and bridged-tee oscillators

There are several other types of sine-wave oscillators based on RC networks. The circuit in Fig. 4 is called a twin-tee oscillator because its feedback network consists of two T-shaped networks. Note that those networks are, in a sense, opposites. One uses series resistors and a shunt capacitor, and the other uses series capacitors and a shunt resistor. If  $R1 = R2 = R3$  and  $C1 = C2 = C3$ , the circuit's oscillating frequency is about:

$$f = 1/(2\pi RC)$$

A more useful form of that equation is:

$$R = 1/(2\pi fC)$$

For example, when each capacitor has a value of  $0.01 \mu\text{F}$ , the resistance required for a 500-Hz twin-tee oscillator is:

$$R = 1/(2 \times 3.14 \times 500 \times 0.01 \times 10^{-6})$$

$$R = 1/(3.14 \times 10^{-5})$$

$$R = 31,831 \text{ ohms}$$

Another type of "tee" oscillator is called the bridged-tee oscillator. In that type of circuit, an RC tee-network is bridged by either a resistor or a capacitor. If the series elements of the tee-network are capacitors, then the bridging element will be a resistor (Fig. 5). If the series elements are resistors, then the bridging element will be a capacitor (Fig. 6).

#### Generating sine waves

As we have seen, the output amplitude of many sine wave oscillators tends to be unstable. On the other hand, the output

amplitude of a square wave oscillator is inherently stable because it operates in a saturating mode wherein the output swings between two well-defined voltages. Therefore some designers prefer to use a square wave or a triangle wave generator as the basic oscillator, and then shape its output into a sine wave.

Extracting a sine wave from a wave of some other shape is possible because all non-sinusoidal waveforms are composed of a number of sine waves summed together. The square wave and the triangle wave, for example, contain a sine wave at the fundamental frequency and a number of harmonics (multiples) of the fundamental frequency. For example, a square wave with a fundamental frequency of 200 Hz would be composed of a 200-Hz sine wave, plus 400-Hz, 600-Hz, 800-Hz, ... sine waves.

If we filter out all of the harmonics, we'll be left with a sine wave at the fundamental frequency. The purity of the sine wave can be quite good, especially if a high order of filtering is used. As shown in Fig. 7, we can use a lowpass or bandpass filter.

#### Wide-range oscillators

Another way to bypass the limited frequency range of an RC oscillator is to use a dual-oscillator circuit; that type of circuit was popular in the 1950's. As shown in Fig. 8, the frequency of one oscillator is fixed (at 100 kHz); the other oscillates at a variable frequency (80–100 kHz) that is determined by the user. Both oscillators are LC types.

Their signals are fed to a non-linear mixer, the output of which is a new signal whose frequency is equal to the difference between the frequencies of the two input signals. That signal is sent through a lowpass filter to remove residual traces of  $f_1$  and  $f_2$ , and then to an amplifier and the outside world.

For example, when  $f_1$  is 100 kHz, the difference between  $f_1$  and  $f_2$  is 0 Hz, so there is no output. However, when  $f_1$  is 80 kHz, the output frequency is  $100 - 80 = 20$  kHz. So the output frequency may vary from 0 to 20 kHz.

In our next installment we'll discuss RC triangle wave and square wave oscillators; in addition we'll introduce the monostable multivibrator circuit. R-E

# CIRCUITS

IF YOU HAVE EVER DESIGNED AN ELECTRONICS project, you probably know that the job goes faster with an organized method for documenting the device as you build it. Despite that, diagrams and notes are usually produced as an afterthought, especially by less experienced designers. But rather than being a chore, or something that slows down the process of getting a project up and running, effective documentation can greatly reduce the time it takes to design an effective circuit. That's because poor documentation, or none at all, can cause design errors and construction mistakes, and constant re-checking; that can make building of a project drag on for weeks when it really should take only days.

To focus on methods for applying pa-

## From Brainstorm

perwork to electronics construction projects, this article splits the record-keeping task into manageable pieces. We'll look at a drawing plan that can be used to completely describe any type of electronics equipment, and we'll show you how to make that plan a part of the creative process as you design your own project. We'll also show you a way to keep track of circuit wiring during the construction phase of your project. It can be applied to point-to-point, wire-wrap, or PC-board construction and automatically shows what has been connected to what, and simplifies keeping track of progress.

### Starting the paper trail

The process of getting an idea, diddling with it, deciding to do it, then establishing a formal set of drawings to control the project is shown in block-diagram form in Fig. 1. If you follow the procedure shown, when you finish you'll have a document that fully describes the device, the hardware housing it, and the history of your experience with it. The documentation process does not take long. Instead, it

## to Bread Board

*There are a lot of twists in the road between a good idea and a properly working circuit. In this article we'll show you how good paperwork, like a good map, can keep you from getting lost!*

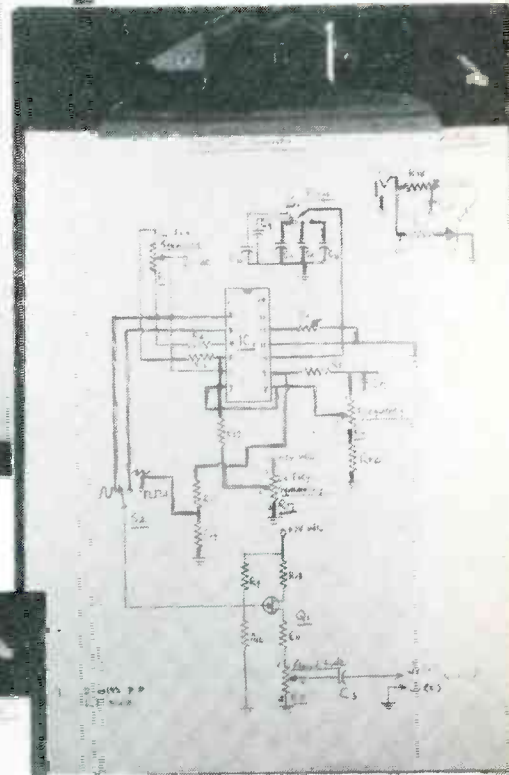
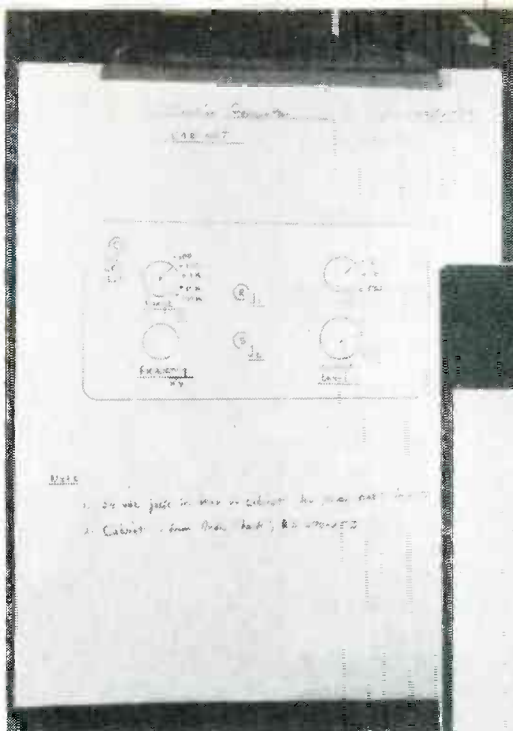

DAVID J. SWEENEY

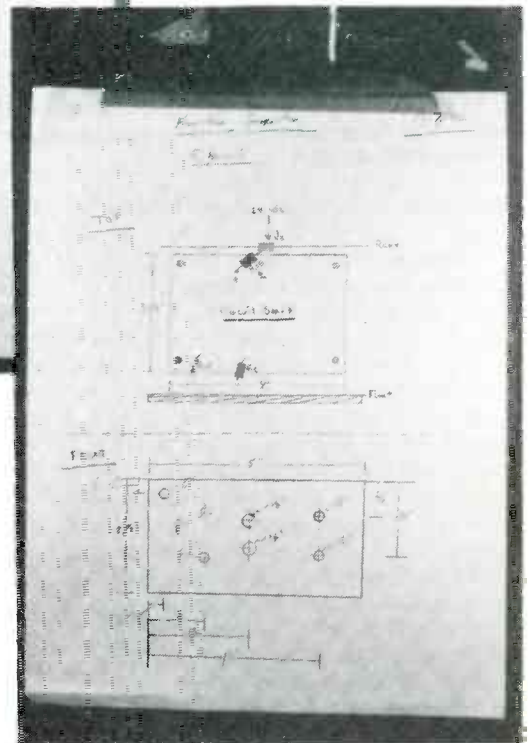
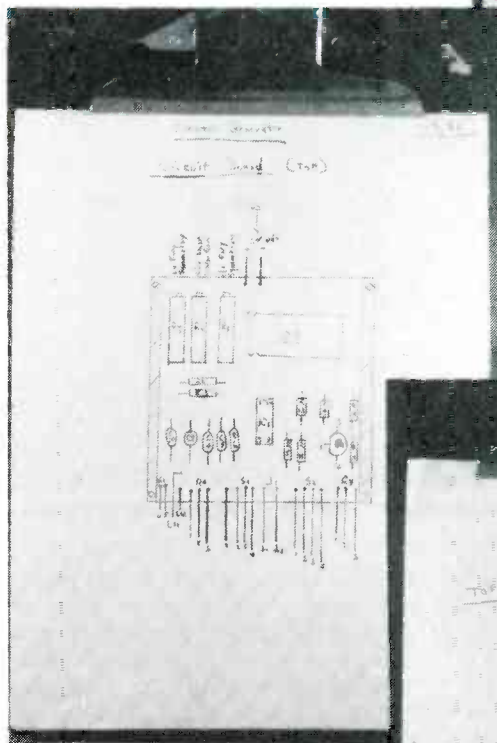

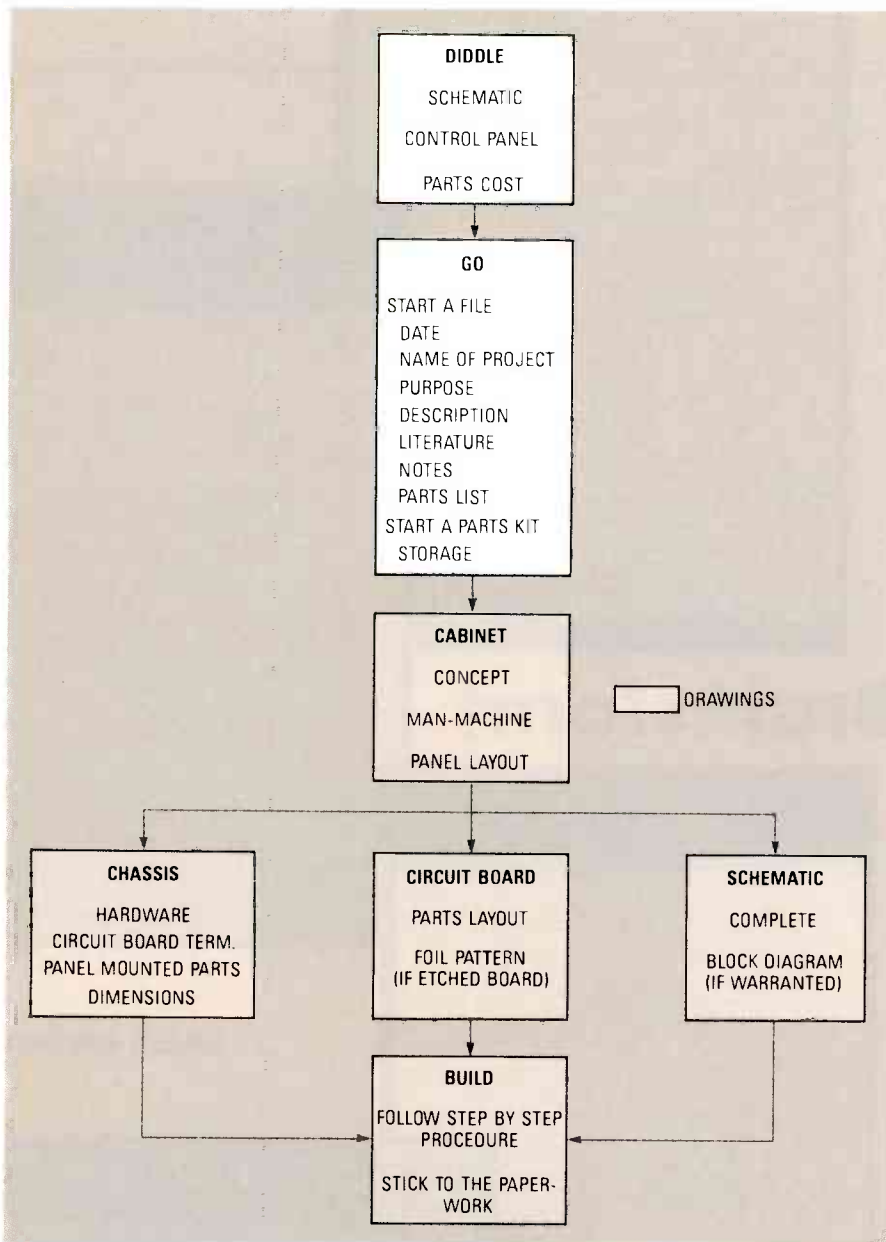

FIG. 1—THIS FLOW CHART shows the proper sequence of steps for turning your brainstorm into a properly working project.

saves time. You begin in the “diddle” stage.

During the diddle stage, the idea germinates. You sketch a schematic, make some changes, theorize about how the circuit works, and decide whether you have the time and money to build the device. The device requires controls, so you diddle with the front-panel layout, add more controls, and imagine how nice the device will look. You might also consider the possibility of using parts from your junk-box. Perhaps you can use the audio section from a portable stereo you stopped using long ago or the control board from a mothballed printer. In addition, you might search a library for books or magazines with useful information.

After diddling with the various aspects of the project, you enter the “go” stage. In the go stage, you gather the informa-

tion that forms the basis for the project. First, open a document file. Enter the name of the project, the purpose of the device, any preliminary sketches, and a list of the parts you will need. Also, establish a project kit—simply a box for keeping the construction materials as you acquire them. If the idea requires a lot of complex circuitry, generate a block diagram and place it in the file. If a magazine article sparked the project, it, too, should go in the file. Finally, any other information regarding use or purpose should be included.

You’re entering all of that information for a good reason: If you get sidetracked for a while, when you get back to the project you could find that you have forgotten some of the details. A lot of very good ideas get lost that way.

After you’ve completed the steps out-

lined in the go stage, it’s time to make the drawings that will become the formal documentation for the project. Four separate drawings should be made. Those are cabinet layout, chassis layout, schematic, and circuit layout. All of the drawings must coordinate with each other. If done properly, those drawings will contain all the information required to completely describe any device under construction.

## Cabinet

In many ways, the cabinet design is the one from which all of the other designs evolve. That’s because the cabinet’s design can directly affect any of the subsequent drawings. Even a simple change can affect the layout of the chassis or the circuit board. Those changes can, in turn, cause changes in the appearance of the schematic.

When designing the cabinet, thought should be given to both function and aesthetics; after all, the cabinet is the “interface” between the user and the device. More is involved here than mere appearance. Careful design should consider the mechanical factors in the operation and mounting of the various potentiometers, trimmers, switches, jacks, meters, displays, or what have you. Some considerations are obvious—spacing between controls must be sufficient to allow for comfortable operation. Others, however, may not become apparent until after you’ve cut the mounting holes. What may be a relatively small knob on the exterior can be attached to a relatively large rotary switch on the interior. If spacing is too tight, there might be insufficient clearance to mount all of the controls. To avoid such problems, consider all of the physical requirements for the cabinet as you design the unit’s appearance.

## Chassis

That drawing indicates the relative location of circuit boards, includes hardware dimensions and mounting holes, and locates any other parts that are mounted inside the cabinet. The identification of the electrical components should match the identification in the schematic. For example, if the panel-mounted potentiometer that controls the frequency of a function generator is called R4 in the schematic, it should be labeled R4 in the chassis diagram. In the cabinet drawing that control might have been labeled FREQUENCY; such labeling is acceptable for that drawing only.

In the chassis drawing, the circuit board or boards, regardless of their actual component count, are treated as units. Components that are located off the circuit boards should be shown in their relative positions so that they are easy to spot, but interconnecting wiring should not be shown. Showing such wiring would add

*continued on page 94*



## THE VERSATILE 4007

Need a versatile CMOS building block for a one-of-a-kind application? Then the 4007 is for you. Find out how to use it here.

RAY MARSTON

THE 4007 IS THE SIMPLEST IC IN THE CMOS line. It contains just two pairs of complementary MOSFET's and a CMOS inverter. However, each element is independently accessible, so the elements can be combined in a great variety of ways. In fact, the 4007 is sometimes known as the "design-it-yourself" CMOS IC, as it can function as a digital inverter, a NAND or a NOR gate, or an analog switch. It can also function as a linear device.

Therefore, not only is the 4007 the simplest CMOS IC, but it is also the most versatile. And that makes it an ideal device for demonstrating the principles by which CMOS devices operate to students, technicians, and engineers. In this article we'll examine the 4007 from both theoretical and practical points of view, and we'll include many circuits that you can use as-is in your next design.

### Basic digital operation

The guts of the 4007 are shown in Fig. 1. All MOSFET's in the 4007 are enhancement-mode devices; Q1, Q3, and Q5 are p-channel, and Q2, Q4, and Q6 are n-channel types. The drains and sources of MOSFET's Q1-Q4 are independent; the drain of Q6 is connected to the drain of Q5, so those two MOSFET's compose the inverter mentioned above. Each pair of transistors is protected by a network like the one shown in Fig. 2.

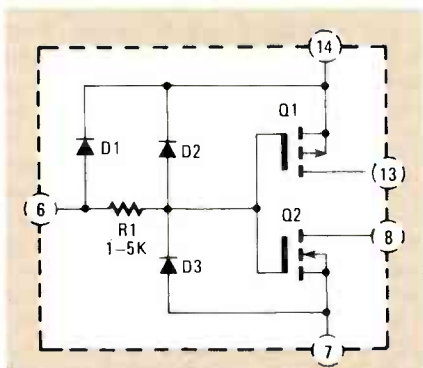

FIG. 2—INPUT PROTECTION CIRCUITRY (R1, D1-D3) of each pair of MOSFET's is shown here.

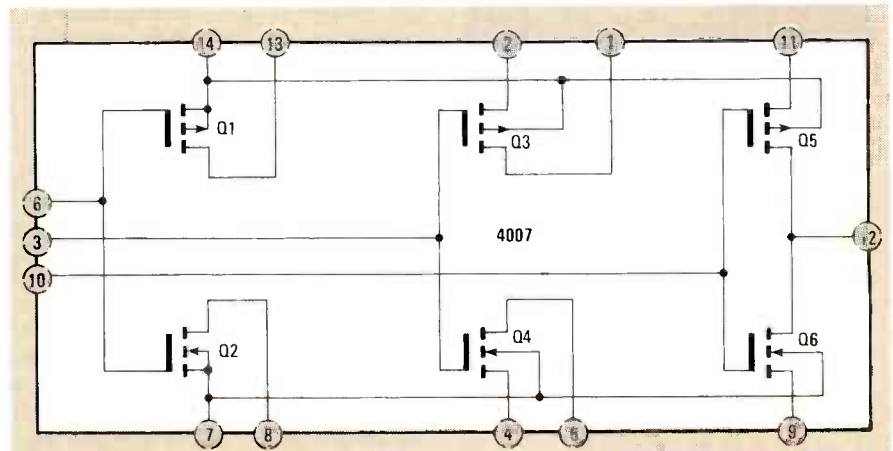

FIG. 1—THE 4007 IS COMPOSED OF three pairs of complementary enhancement-mode MOSFET's.

As you recall, the term *CMOS* is an acronym for *Complementary Metal Oxide Semiconductor*; it is fair to say that most CMOS IC's are designed around CMOS devices like those that compose the 4007. Therefore it is worthwhile to get a good understanding of how those elements work. Let's look first at their digital characteristics; later we'll examine them in light of their analog capabilities.

The two fundamental characteristics of a MOSFET are as follows. First, the gate, or input terminal, of a MOSFET has a near-infinite impedance. Second, the magnitude of the voltage applied to the gate controls the magnitude of drain-to-source current flow.

In an enhancement-mode *n*-channel MOSFET the drain-to-source circuit is a high impedance when the gate is at the same potential as the source. However, that impedance decreases as the potential applied to the gate becomes positive with respect to the source. So an *n*-channel MOSFET can be used as a digital inverter by wiring it as shown in Fig. 3-a. With a low applied to its input the MOSFET is cut off, so the output goes high. With a high applied to its input the MOSFET saturates, so the output goes low.

In a *p*-channel enhancement-mode MOSFET the drain-to-source circuit is also a high impedance when the gate is at the same potential as the source. But, unlike the *n*-channel device, that imped-

ance decreases as the potential applied to the gate becomes *negative* with respect to the source. So a *p*-channel MOSFET can be used as a digital inverter by wiring it as shown in Fig. 3-b.

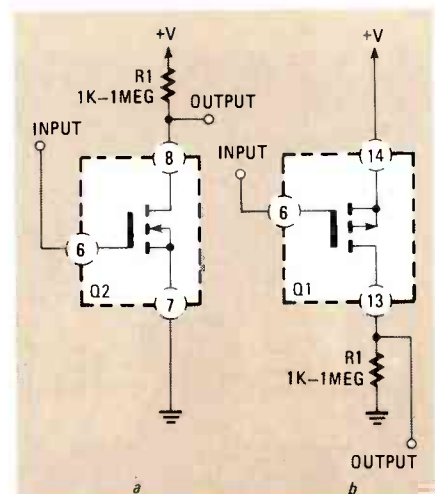

FIG. 3—A DIGITAL INVERTER can be built from either an *n*-(a) or a *p*-channel MOSFET (b).

In both *n*- and *p*-channel inverters, the amount of current that flows through the device is limited by the value of R1. And both circuits draw a finite quiescent current in the on state. However, quiescent current drain can be reduced to almost zero by connecting a pair of complementary MOSFET's as shown in Fig. 4.

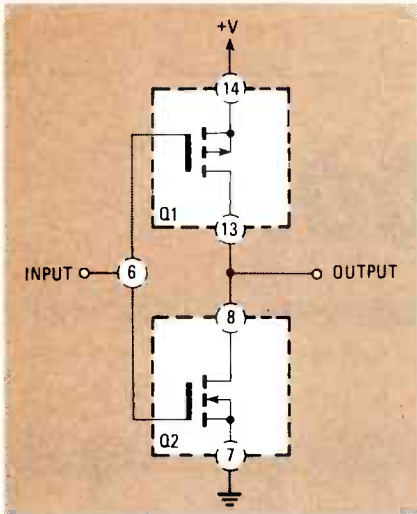

FIG. 4—THE STANDARD CMOS INVERTER is built from two stacked MOSFET's.

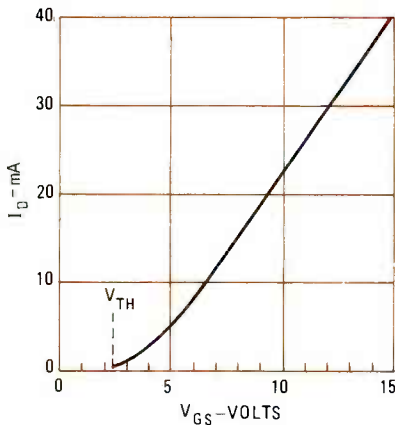

FIG. 5—THE N-CHANNEL MOSFET conducts almost no current until  $V_{GS}$  exceeds about 2 volts.

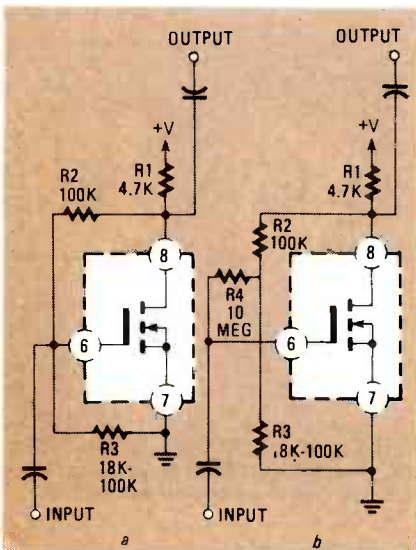

FIG. 6—LINEAR OPERATION OF A 4007 MOSFET requires simple biasing (a); very high input impedance is achieved by the addition of R4 (b).

In that configuration, which is standard for many CMOS inverters and buffers,

with a low applied to the input. Q1 is on, so the output is high. However, Q2 is off, so no quiescent current can flow. With a high applied to the input. Q2 is on, so the output is low. In that case Q1 is off, so quiescent current flow is still nil. Of course, there is no requirement that the MOSFET's be operated solely in the digital mode; let's find out how they can be used otherwise.

### Basic linear operation

To understand the operation of CMOS circuitry, it is essential to understand the linear characteristics of the basic MOSFET. Figure 5 shows the typical gate-voltage ( $V_{GS}$ ) to drain-current ( $I_D$ ) curve of an n-channel enhancement-mode MOSFET. Note that negligible drain current flows until the gate voltage rises to a threshold value,  $V_{TH}$ , of about 1.5 to 2.5 volts. After that point, however, drain current increases almost linearly with further increases in gate voltage.

Figure 6-a shows how to connect an n-channel MOSFET as a linear inverting amplifier. Resistor R1 is the drain load, and R2 and R3 bias the gate so that the device operates in the linear range. The value of R3 must be selected to give the desired quiescent drain current; it normally ranges from 18–100K. To provide the linear amplifier with a very high input impedance, wire a 10-megohm resistor (R4) as shown in Fig. 6-b.

Figure 7 shows typical VI characteristics of an n-channel MOSFET at various fixed values of  $V_{GS}$ . To understand that graph, imagine that, for each curve,  $V_{GS}$  is fixed at  $V_{DD}$ , but that  $V_{DS}$  can be varied by altering the value of the drain-load resistor. The graph can then be divided into two characteristic regions, as indicated by the dotted line: the ohmic region and the pinch-off region.

For each curve shown in Fig. 7, the beginning of the pinch-off region—the point where the dashed line crosses the solid line—is called the pinch-off voltage, or  $V_{p}$ , which is the value of  $V_{DS}$  above which  $I_D$  increases little, if at all, for further increases in  $V_{DS}$ .

When the MOSFET is in the pinch-off region and  $V_{DS}$  is more than 50% of  $V_{GS}$ , the drain functions as a constant-current source. The amount of current that flows is controlled by  $V_{GS}$ . A low value of  $V_{GS}$  gives a low current flow, and a high value of  $V_{GS}$  gives a high current flow. Those saturated constant-current characteristics protect CMOS devices from short-circuit failure and also determine operating speed at various supply voltages. Both current-drive and operating speed increase in proportion to the supply voltage.

When the MOSFET is in the ohmic region and  $V_{DS}$  is less than 50% of  $V_{GS}$ , the drain functions as a voltage-controlled resistance. That resistance increases approximately as the square of  $V_{GS}$ .

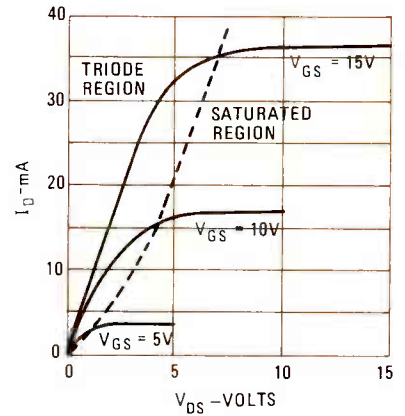

FIG. 7—AN N-CHANNEL MOSFET operates linearly in the ohmic region above the dashed line and digitally in the pinch-off region below the dashed line.

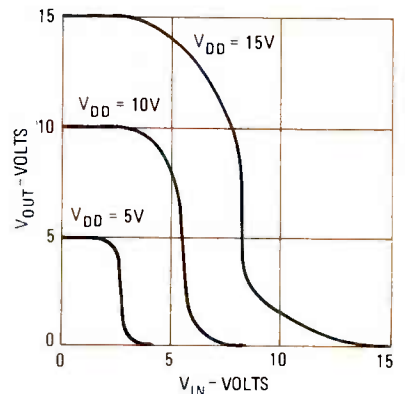

FIG. 8—VOLTAGE-TRANSFER characteristic of the CMOS inverter (Fig. 4) reveals that, for inputs near ground and  $V_{DD}$ , output changes very little.

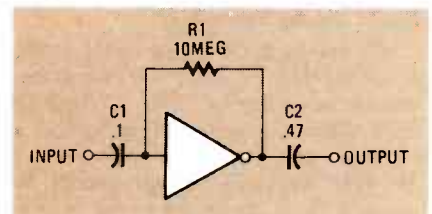

FIG. 9—LINEAR OPERATION of the inverter (Fig. 4) is possible, as shown here.

Figure 8 shows typical voltage-transfer characteristics of the standard CMOS inverter at different supply voltages. Note that when  $V_{DD}$  is 15 volts, the output voltage changes a very small amount when the input voltage is near either zero or  $V_{DD}$ . However, when the input voltage is biased at roughly  $V_{DD}/2$ , a small change in input voltage produces a large change in output voltage. Typically, the inverter has a voltage gain of about 30 db when used with a 15-volt supply, and 40 db at 5 volts. Figure 9 shows how to connect the CMOS inverter for use as a linear amplifier; the circuit has a bandwidth of 710 kHz at 5 volts, and 2.5 Mhz at 15 volts.

We can wire three simple CMOS inverters (like the one shown in Fig. 4) in series

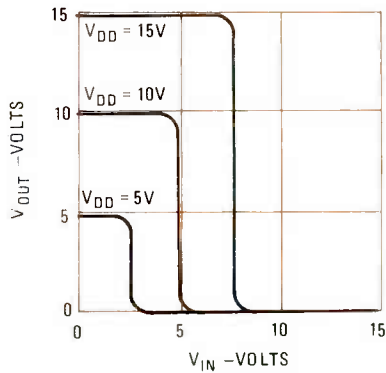

FIG. 10—VOLTAGE-TRANSFER characteristic of a B-series CMOS inverter is similar to that of the simple inverter.

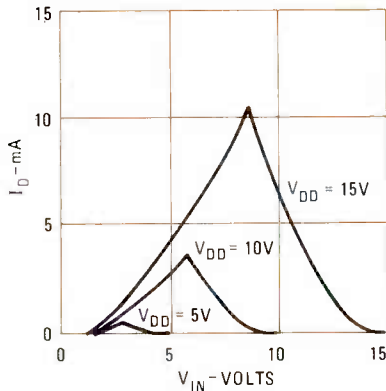

FIG. 11—DRAIN CURRENT of the simple inverter peaks at an input voltage just over  $V_{DD}/2$ .

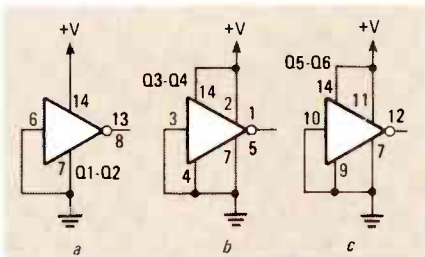

FIG. 12—DISABLE AN UNUSED INVERTER pair as shown here: Q1 and Q2 are disabled as in a; Q3 and Q4 as in b; Q5 and Q6 as in c.

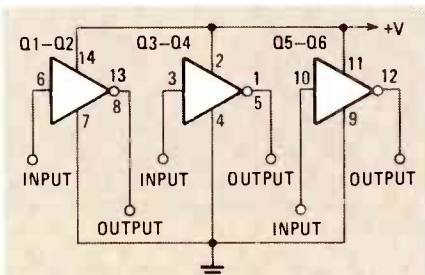

FIG. 13—EACH PAIR OF TRANSISTORS may be used independently as an inverter.

to obtain the direct equivalent of a modern "buffered" B-series inverter, which has the overall voltage transfer curve shown in Fig. 10. A B-series inverter typically gives

about 70 db of linear voltage gain, but it tends to be quite unstable when used in the linear mode.

To finish up our discussion of basic operation, take a look at Fig. 11. Shown there is the drain-current transfer characteristics of the simple (non-buffered) CMOS inverter. Note that drain current is zero when input voltage is zero or  $V_{DD}$ . However, in the middle range, current rises to a maximum value when the input is at approximately  $V_{DD}/2$ , at which point both MOSFET's are on. That on current can be reduced by wiring resistors in series with the source of each MOSFET. We'll use that technique in the "micro-power" circuits discussed below.

### Basic rules

There are a few basic rules to follow in order to use the 4007 successfully. First, you must ensure that all unused elements of the devices are disabled. A pair of MOSFET's can be disabled by connecting their inputs. As shown in Fig. 12-a, to disable the Q1-Q2 pair, just ground pin 6. To disable the other pairs, in addition to grounding the inputs, the sources and drains must be connected to ground and +V as shown in Fig. 12-b and Fig. 12-c.

In use, the input terminals must not be allowed to rise above  $V_{DD}$  (the supply voltage) or below ground. To use an n-channel MOSFET, the source must be tied to ground, either directly or through a current-limiting resistor. To use a p-channel MOSFET, the source must be tied to  $V_{DD}$ , either directly or through a current-limiting resistor.

### Digital circuits

A single 4007 can be configured as three independent inverters, as shown in Fig. 13. In that figure, and in others that follow, we won't necessarily show all details of how to wire the circuit under discussion. Also, multiple pin connections that terminate in a single function will be shown as in Fig. 13. For example, the output of the Q1-Q2 inverter in that figure is obtained by connecting pins 13 and 8 together.

Figure 14 shows how to connect the 4007 as one inverting and one non-inverting buffer. In the non-inverting circuit, the Q1-Q2 and Q3-Q4 inverters are simply wired in series to provide two stages of inversion—which provides a non-inverting buffer.

The maximum source (load-driving) and sink (load-absorbing) currents of a simple CMOS inverter are about 10–20 mA when either output MOSFET is fully on. To increase that sink current, several n-channel MOSFET's can be connected in parallel in the output stage. Figure 15 shows how to configure the 4007 as a high sink-current inverter. Similarly, Fig. 16 shows how to configure the IC as a high

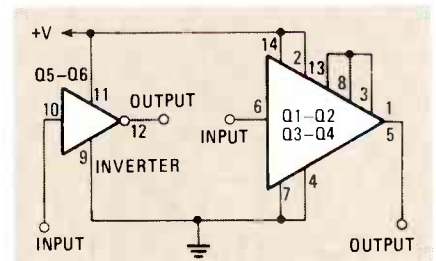

FIG. 14—A NON-INVERTING BUFFER is composed of two inverters connected in series (Q1-Q4). The other inverter (Q5 and Q6) can be used independently.

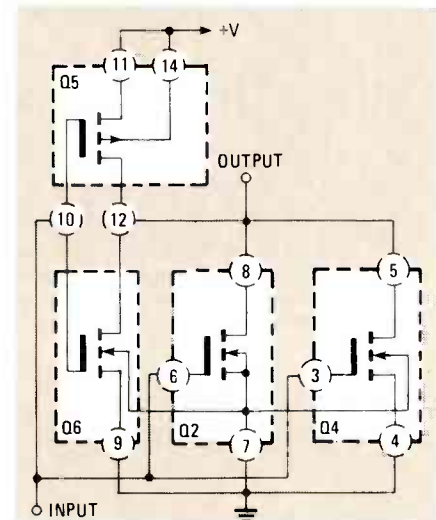

FIG. 15—SINK CURRENT may be increased by connecting the n-channel MOSFET's in parallel.

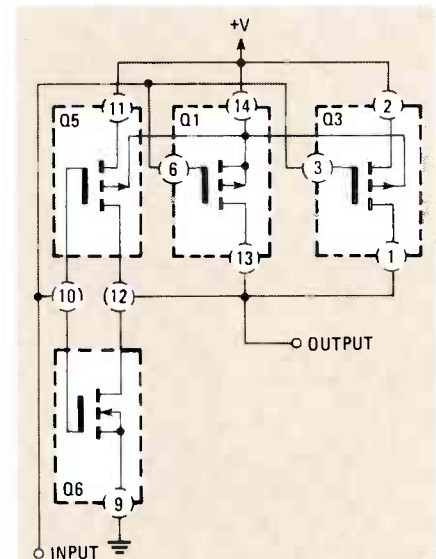

FIG. 16—SOURCE CURRENT MAY BE INCREASED by connecting the p-channel MOSFET's in parallel.

source-current inverter. Last, Fig. 17 shows how to connect all the elements of a 4007 in parallel to produce a single inverter that will both sink and source three times the current of a standard inverter.

### Logic circuits

The 4007 is well-suited for demonstrating the basic principles of CMOS logic

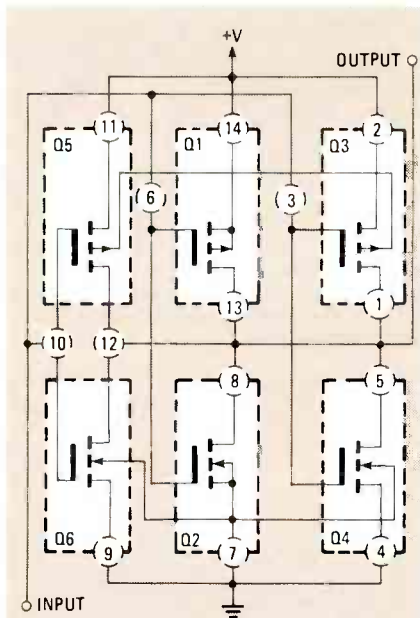

FIG. 17—BOTH SINK AND SOURCE CURRENT may be increased by connecting all transistors of each type in parallel.

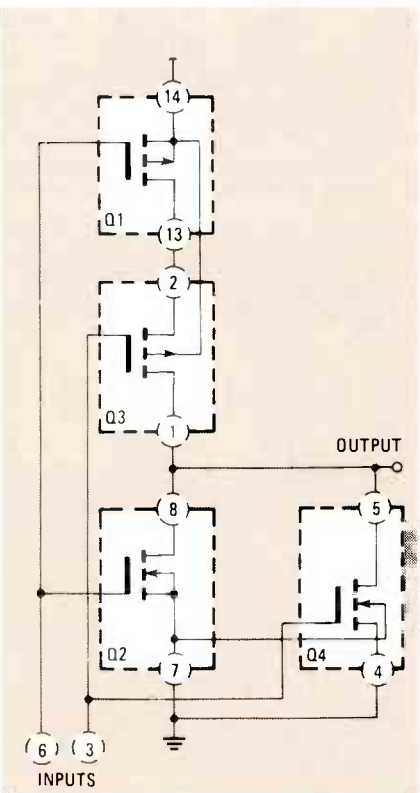

FIG. 18—A TWO-INPUT NOR GATE can be built from a 4007.

gates. Figure 18 shows how to configure the 4007 as a 2-input NOR gate. In that circuit two n-channel MOSFET's are wired in parallel so that either can pull the output to ground with a high input. Also, two p-channel MOSFET's are wired in series so that, with low inputs, both must turn on to pull the output high. Figure 19 shows how to wire up a 3-input NOR gate;

it is composed of three series- and three parallel-connected MOSFET's, and its principle of operation is the same as the 2-input circuit. Figure 20 shows how to con-

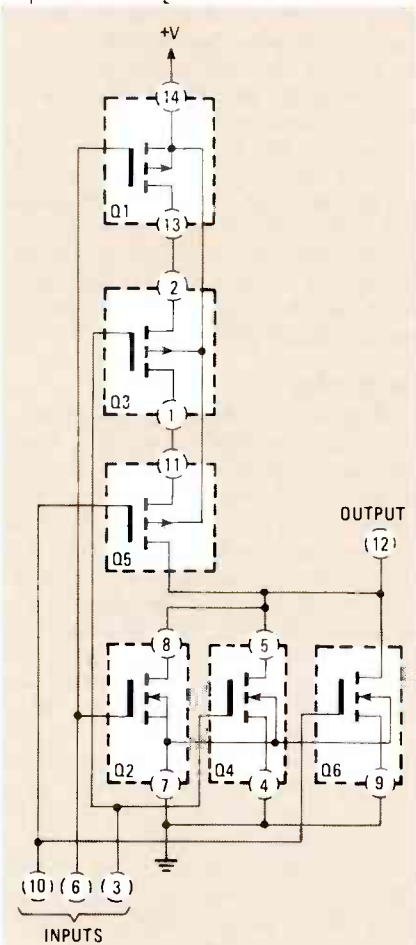

FIG. 19—A THREE-INPUT NOR GATE can be built from a 4007.

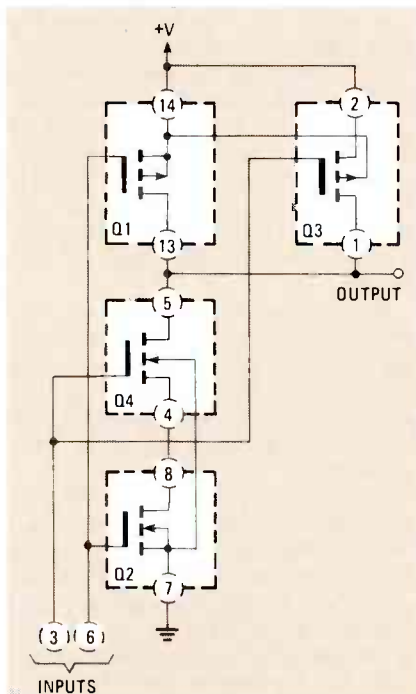

FIG. 20—A TWO-INPUT NAND GATE can be built from a 4007.

figure the 4007 as a 2-input NAND gate. When both inputs are high, Q2 and Q4 both turn on, so the output goes low. Otherwise Q1 or Q3 pull the output high.

An important element of many digital circuits is called an analog switch. It is an electronically-controlled SPST, SPDT, or other switch. The principle of the SPST type is shown in Fig. 21-a. When the control input is high, signals can flow between points x and y unimpeded. When that input is low, no signal can flow.

The 4007 analog switch has a near-infinite off resistance and an on resistance of about 600 ohms. It can handle signals between zero volts and the positive supply voltage. And since the gate is bilateral, terminals x and y can function as either input or output.

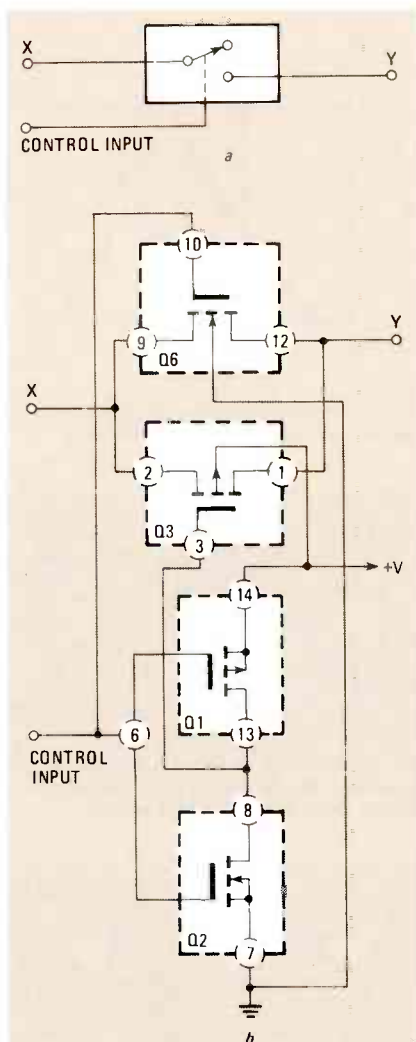

FIG. 21—AN SPST ANALOG SWITCH can be built from a 4007.

Circuitry to implement the SPST switch is shown in Fig. 21-b. An n-channel and a p-channel MOSFET are wired in parallel (source-to-source and drain-to-drain), but their gate signals are applied out of phase by means of the Q1-Q2 inverter. To turn the Q3-Q6 pair of transistors on, Q6's gate must be high, and Q3's gate

low; to turn the switch off, the opposite conditions must be present.

An SPDT analog switch is shown in Fig. 22-a; circuitry which accomplishes that function is shown in Fig. 22-b. Here two transmission elements are connected in parallel, but their control voltages are applied out of phase, so that one switch opens when the other closes, and vice versa.

We saw earlier that the 4007 can also be used in a linear mode; now let's look at how to do that, and at the sort of performance we can expect from a linearly-operated 4007.

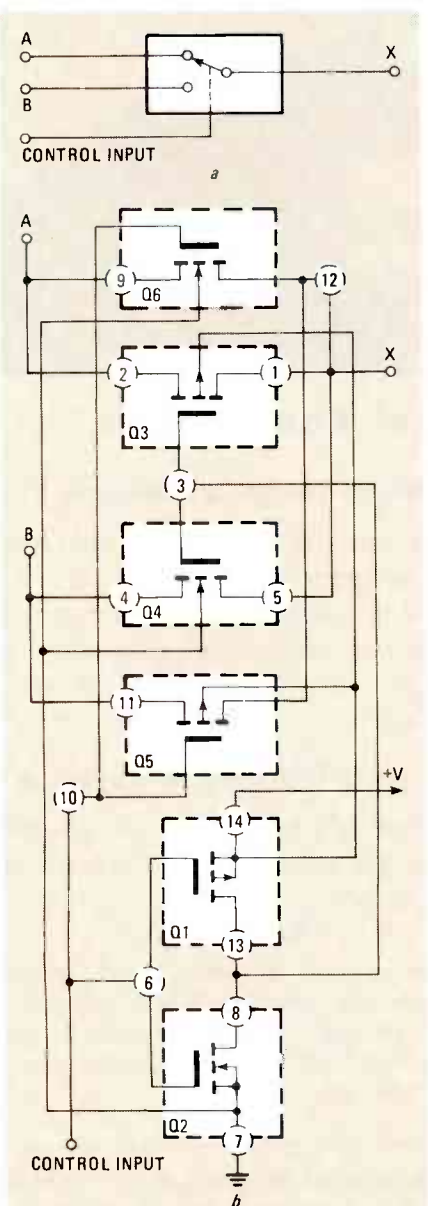

FIG. 22—AN SPDT ANALOG SWITCH can be built from a 4007.

### Linear circuits

Figure 23 shows how voltage gain and frequency response vary according to supply voltage. The curves shown in that figure assume that the 4007 is driving a high-impedance (10 megohm), low-capacitance

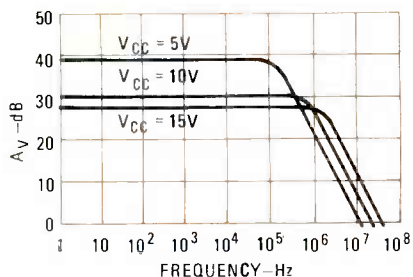

FIG. 23—FREQUENCY RESPONSE and voltage gain of a linear-mode CMOS amplifier is dependent partially on supply voltage.

probe (15 pF) scope probe. The output impedance of the open-loop amplifier typically varies from 3K (at 15 volts) to 5K (at 10 volts) to 22K (at 5 volts). The product of the output impedance and the output load capacitance determines the circuit's bandwidth. Increasing either load capacitance or output impedance decreases bandwidth.

As you can see in the voltage transfer curve back in Fig. 8, the distortion characteristics of the CMOS linear amplifier are

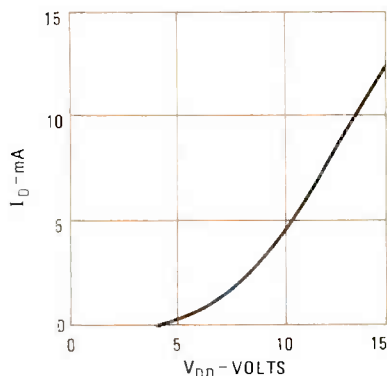

FIG. 24—VERY LITTLE CURRENT FLOWS until  $V_{DD}$  exceeds 5 volts.

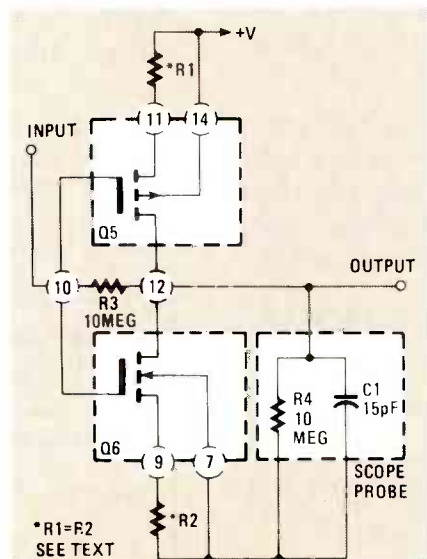

FIG. 25—SOURCE RESISTORS R1 AND R2 decrease current consumption drastically.

TABLE 1—LINEAR-MODE PERFORMANCE

R1/R2	$I_D$	$A_v$	Bandwidth
0	12.5mA	20	2.7 MHz
100Ω	8.2mA	20	1.5 MHz
560Ω	3.9mA	25	300 kHz
1K	2.5mA	30	150 kHz
5.6K	600μA	40	25 kHz
10K	370μA	40	15 kHz
100K	40μA	30	2 kHz
1MEG	4μA	10	1 kHz

not particularly impressive. Linearity is good for small-amplitude signals, but distortion increases progressively as the output swing approaches the upper and lower limits of the power supply.

Figure 24 shows the typical drain-current versus supply-voltage characteristic of the basic CMOS linear amplifier. Note that supply current typically varies from 0.5 mA at 5 volts to 12.5 mA at 15 volts.

As we mentioned above, in many applications, the quiescent supply current of a 4007 CMOS amplifier often can be reduced (at the expense of reduced bandwidth) by wiring external resistors in series with the source terminals of the two MOSFET's. In Fig. 25 we show how a micropower circuit would be configured.

It is important to understand that the source resistors increase the output impedance of the amplifier; output impedance is roughly equal to the product of R1 and  $A_v$ . That impedance, and the resistance and the capacitance of the load affect the circuit's gain and bandwidth.

Table 1 shows how supply current, voltage gain, and bandwidth vary with the value of those source resistors. As you can see, with 10K source resistors, bandwidth is about 15 kHz. However, by increasing load capacitance to 50 pF, bandwidth decreases to about 4 kHz; by reducing capacitance to 5 pF, bandwidth increases to 45 kHz. Similarly, reducing the resistive load from 10 megohms to 10 kilohms causes voltage gain to fall to unity. The conclusion is that, to obtain significant gain, load resistance must be large relative to the amplifier's output impedance.

An unbiased 4007 inverter has an input capacitance of about 5 pF and an input resistance near infinity. So, if the output of the circuit in Fig. 25 is tied directly to the input of another 4007 stage, the overall voltage gain will be about 30 dB, and the bandwidth will be about 3 kHz. Those values will be obtained when R1 has a value of 1 megohm. For extremely low current drain ( $.4 \mu A$ ), R1 could be increased to 10 megohms.

Now you can see why we said that the 4007 is the most versatile CMOS IC. With the ideas we've presented here, you should have no trouble thinking of many more applications for the 4007. **R-E**

# Where's Your **ELECTRONICS** Career Headed?

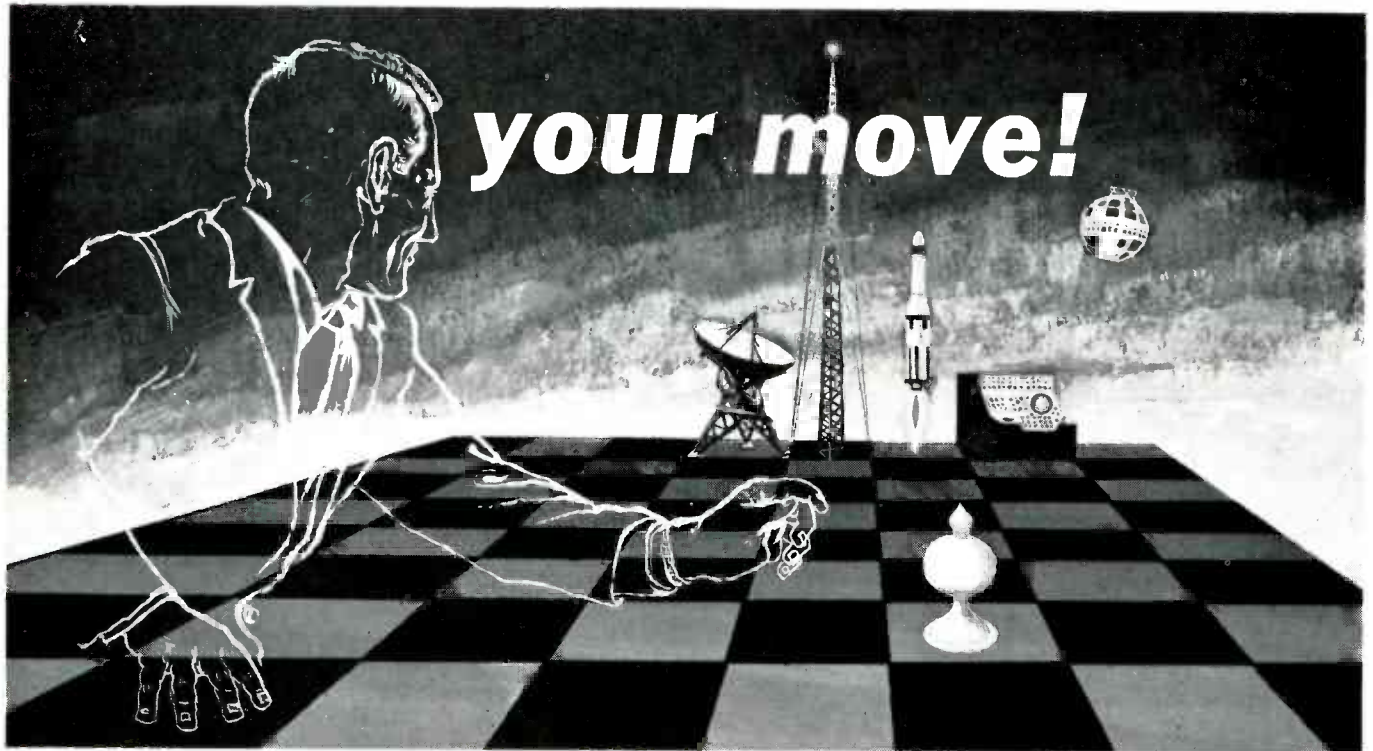

## The Move You Make Today Can Shape Your Future

Yes it's your move. Whether on a chess board or in your career, you should plan each move carefully. In **electronics**, you can *move ahead* faster and further with a

## **B. S. DEGREE**

Put professional knowledge and a COLLEGE DEGREE in your electronics career. Earn your degree through independent study at home, with Grantham College of Engineering. No commuting to class. Study at your own pace, while continuing your present job.

The accredited Grantham non-traditional degree program is intended for mature, fully employed workers who want to upgrade their careers . . . and who can successfully study electronics and supporting subjects through

### **INDEPENDENT STUDY, AT HOME**

Free Details Available from:

**Grantham College of Engineering**  
10570 Humbolt Street  
Los Alamitos, California 90720

### **Independent Home Study Can Prepare You**

Study materials, carefully written by the Grantham staff for independent study at home, are supplied by the College, and your technical questions related to those materials and the lesson tests are promptly answered by the Grantham teaching staff.

### **Recognition and Quality Assurance**

Grantham College of Engineering is accredited by the Accrediting Commission of the National Home Study Council.

All lessons and other study materials, as well as communications between the college and students, are in the English language. However, we have students in many foreign countries; about 80% of our students live in the United States of America.

**Grantham College of Engineering** R-09-86  
10570 Humbolt Street, Los Alamitos, CA 90720

Please mail me your free catalog which explains your B.S. Degree independent-study program.

Name \_\_\_\_\_ Age \_\_\_\_\_

Address \_\_\_\_\_

City \_\_\_\_\_ State \_\_\_\_\_ Zip \_\_\_\_\_

# PC SERVICE

One of the most difficult tasks in building any construction project featured in **Radio-Electronics** is making the PC board using just the foil pattern provided with the article. Well, we're doing something about it.

We've moved all the foil patterns to this new section where they're printed by themselves, full sized, with nothing on the back side of the page. What that means for you is that the printed page can be used directly to produce PC boards!

**Note:** The patterns provided can be used directly only for *direct positive photoresist methods*.

In order to produce a board directly from the magazine page, remove the page and carefully inspect it under a strong light and/or on a light table. Look for breaks in the traces, bridges between traces, and in general, all the kinds of things you look for in the final etched board. You can clean up the published artwork the same way you clean up your own artwork. Drafting tape and graphic aids can fix incomplete traces and doughnuts, and you can use a hobby knife to get rid of bridges and dirt.

An optional step, once you're satisfied that the artwork is clean, is to take a little bit of mineral oil and carefully wipe it across the back of the artwork. That helps make the paper translucent. Don't get any on the front side of the paper (the side with the pattern) because you'll contaminate the sensitized surface of the copper blank. After the oil has "dried" a bit—patting with a paper towel will help speed up the process—place the pattern front side down on the sensitized copper blank, and make the exposure. You'll probably have to use a longer exposure time than you are probably used to.

We can't tell you exactly how long an exposure time you will need but, as a starting point, figure that there's a 50 percent increase in exposure time over lithographic film. But you'll have to experiment to find the best method for you. And once you find it, stick with it. Don't forget the "three C's" of making PC boards—care, cleanliness, and consistency.

Finally, we would like to hear how you make out using our method. Write and tell us of your successes, and failures, and what techniques work best for you. Address your letters to:

**Radio-Electronics**  
Department PCB  
500-B Bi-County Blvd.  
Farmingdale, NY 11735

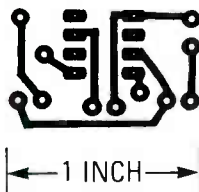

OUR ELECTRONIC SCARECROW can help chase away a less than determined burglar. If you chose to build that circuit on a PC board, here's a pattern that's appropriate.

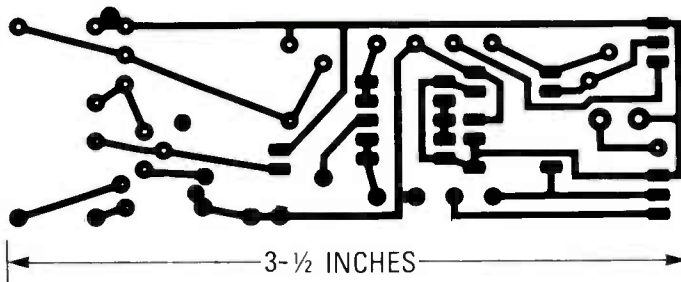

BECAUSE OF THE DANGEROUS VOLTAGES that the stun gun develops, be extra careful when laying out and etching this PC pattern for that circuit.

---

---

# PC SERVICE



# ELENCO PRODUCTS AT DISCOUNT PRICES!

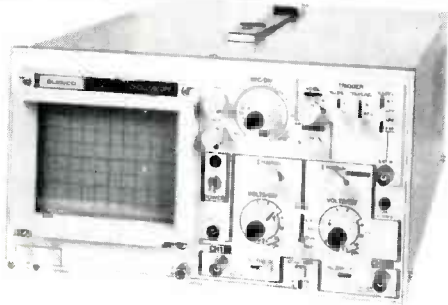

**20 MHz DUAL TRACE OSCILLOSCOPE**  
**\$339** MO-1251

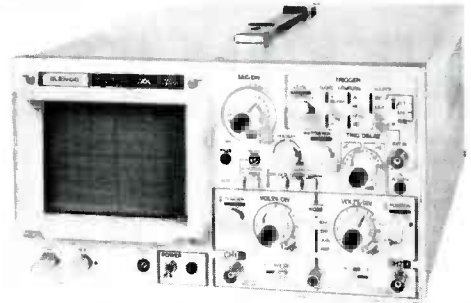

**35 MHz DUAL TRACE OSCILLOSCOPE**  
**\$545** MO-1252

Top quality scopes at a very reasonable price. Contains all the desirable features. Elenco's 2 year guarantee assures you of continuous service. Two 1x, 10x probes, diagrams and manual included. Write for specifications.



**MULTI METER with CAPACITANCE and transistor tester**  
**\$65** Model CM-1500

Reads Volts, Ohms, Current, Capacitors Transistors & Diodes



**TRUE RMS 4 1/2 DIGIT MULTIMETER**  
**\$135** Model M-7000

.05% DC Accuracy  
 .1 % Resistance with Freq. Counter & Deluxe Case

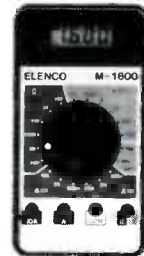

**3 1/2 DIGIT MULTIMETER**  
**\$25** Model M-1600

1% DC Accuracy  
 1% Resistance Reads 10A DC

**GF-8016 Function Generator with Freq. Counter**  
**\$219**

- Sine, Square, Triangle, Pulse, Ramp, .2 to 2 MHz
- Frequency .1 thru 10 MHz

GF 8015 without Freq. Meter \$169

**Quad Power Supply**  
 Including 2-20V Variable Supply



Model XP-575

Fully Regulated, Short Protect Specifications **3 @ \$49.95**

Volts	AMP	Reg	Max Ripple
2-20V	2A	.10V	.005V
12V	1A	.05V	.003V
5V	3A	.10V	.005V
-5V	.4A	.05V	.005V

**Triple Power Supply XP-660**  
**\$149.50**

0-20V @ 1A  
 0-20V @ 1A  
 5V @ 5A

Fully Regulated, Short Circuit Protected with 2 Limit Cont. 3 Separate Supplies.

**3 Amp Power Supply XP-650**  
**\$119.50**

0-40V @ 1.5A  
 0-20V @ 3A

Fully regulated, short circuit protected current limit control



**DIGITAL LCR METER**  
 Model LC-1800  
 Measures: Inductors Capacitors, Resistors  
**\$148**

Inductors .1μH to 200 H  
 Capacitor .1Pf to 200μf  
 Resistor .01Ω to 20M Ω  
 Ranges 6 Ind, 7 cap, 7 res

C&S SALES, 8744 W. North Ter. Niles, IL 60648  
 800-292-7711 (312) 459-9040



**15 DAY MONEY BACK GUARANTEE** ASK FOR CATALOG

2 Year Limited Guarantee! Add 5% for Postage (\$10 max.), IL Res., 7% Tax

CIRCLE 109 ON FREE INFORMATION CARD

# SATELLITE TV



BOB COOPER, JR.,  
SATELLITE-TV EDITOR

## Microwave test equipment

WHEN THE FIRST HOME SATELLITE DISH systems appeared in the marketplace late in 1979, they were priced at just under \$4,000 (wholesale). Most people were astounded that so complex a system could be assembled for so small an amount of money. Competition and technological evolution have improved things to the point that today a system with similar (or improved) performance characteristics sells for as little as \$350 (wholesale). However, it is not just the dish systems themselves that have benefited from the on-going evolution in electronics.

In fact, the growth of TVRO has fueled a number of innovations in the microwave area, but none is more dramatic than the innovations in microwave test equipment. And that new equipment surely must frighten old-line builders of microwave test instruments such as Hewlett Packard. The spectrum analyzer is a case in point. High-performance spectrum analyzers have always cost an arm and a leg. The most important factors to consider include: maximum operating frequency, resolution, sensitivity, and stability.

The unit shown in Fig. 1 is a good example of a low-cost, high-performance spectrum analyzer. We'll discuss it in detail below, but for now let's consider some of the problems involved in setting up a TVRO system, and how a spectrum analyzer can help.

### Installation

Installing a small-dish satellite-receiving system (whether for video, audio, or data communication) has changed little since 1979. First

the components of the system must be brought together. Then the dish must be erected on its mount and outfitted with the necessary electronics. Last, the dish must be aimed at the desired satellite, which is located some 24,000 miles away.

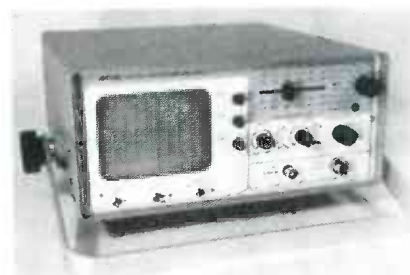

FIG. 1

The aiming process is complicated by the number of satellites now in operation, by those soon to be, and by the rapidly expanding use of the same frequency band (3,700 to 4,200 MHz) for point-to-point terrestrial communications. In short, there are many possibly interfering signal sources, and only one is right for a particular installation.

Of all of the instruments designed to measure the strength and quality of a microwave signal, none approaches the spectrum analyzer for either accuracy or spectral integrity. Unfortunately, however, until very recently the cost of a good microwave spectrum analyzer made those less-accurate instruments more attractive than they, on their own merits, deserved.

### A breakthrough

The good news is that the same technology that made it possible

### TVRO dealer "Starter Kit" available

Bob Cooper's *CSD Magazine* has arranged with a number of TVRO equipment suppliers to provide a single-package of material that will help introduce you to the world of TVRO dealership. A short booklet written by Bob Cooper describes the start-up pitfalls to be avoided by any would-be TVRO dealer, in addition, product data and pricing sheets from prominent suppliers in the field are included. That package of material is free of charge and is supplied to firms or individuals in the electronics service business as an introduction to the 1984/85 world of selling TVRO systems retail.

You may obtain your *TVRO Dealer Starter Kit* free of charge by writing on company letterhead, or by enclosing a business card with your request. Address your inquiries to: *TVRO STARTER KIT, P.O. Box 100858, Fort Lauderdale, FL 33310*. That kit *not* available to individuals not involved in some form of electronics sales and service.

for the price of a TVRO receiver to drop by a factor of 10 (or even 20) has now been applied to the spectrum analyzer. In fact, an entirely new generation of microwave test instruments is now available; many are priced at 10% or less of the cost of the older HP-style units. And they have been designed from the ground up to be portable, self-powered, field-usable instruments.

One portable spectrum analyzer is made by AVCOM of Virginia Inc., (500 South Lake Blvd., Richmond, VA 23235), a veteran of the satellite-TV field. The *PSA-35*, shown in Fig. 1, offers six bands of coverage as follows:

- Below 10 MHz to 770 MHz
- 270 MHz to 770 MHz

# COMPUTER DIGEST

VOL. 3 NO. 9 September 1986

A NEW KIND OF MAGAZINE FOR ELECTRONICS PROFESSIONALS

## SOUP UP YOUR PC

How to turbocharge your computer

A  
**GENSBACK**  
PUBLICATION

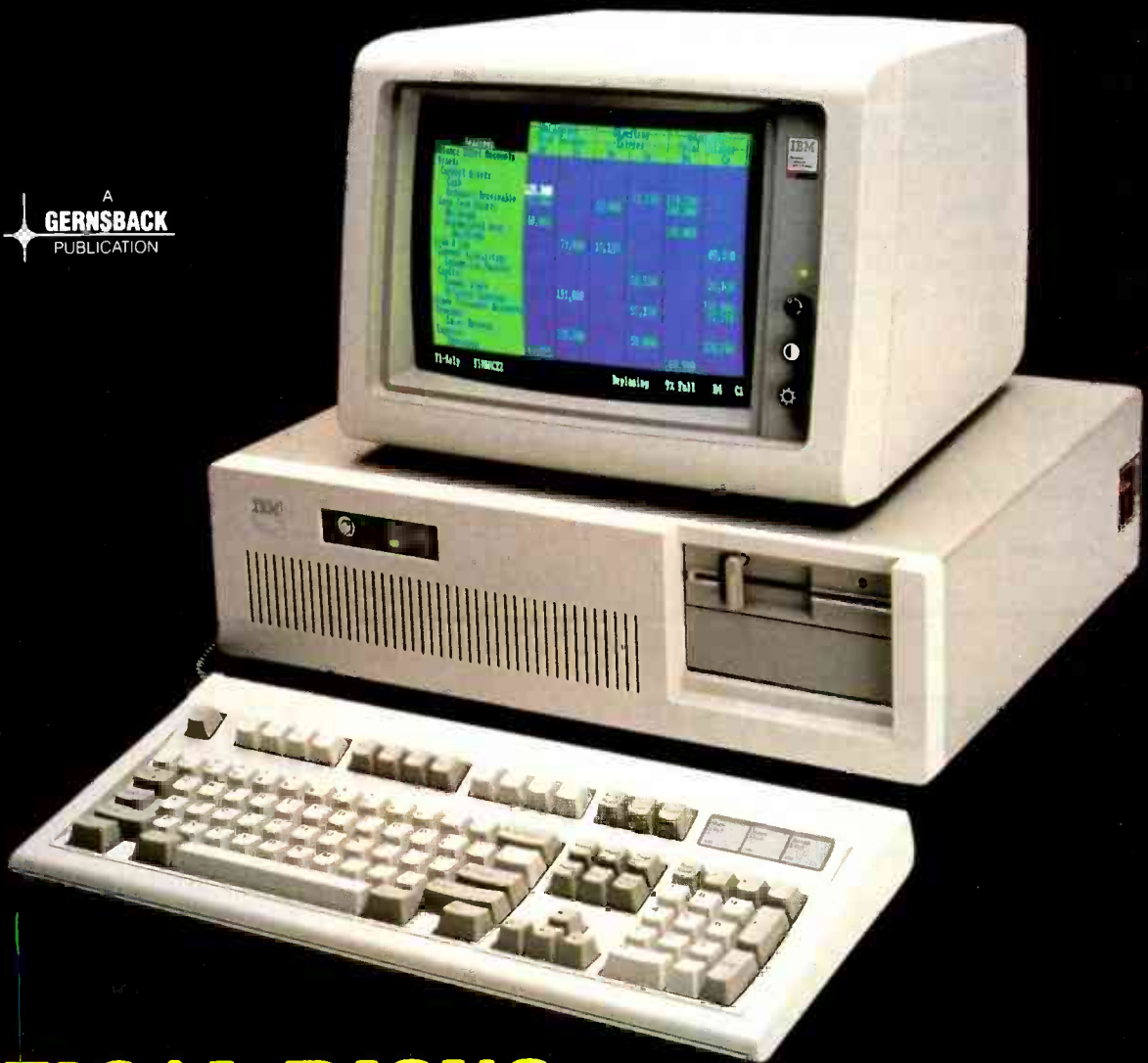

## OPTICAL DISKS

Tomorrow's memory technology

## OKIDATA UPGRADE

Enhancing the Okidata Printer

# CONTENTS

Vol. 3 No. 9

September 1986

## 7 CB Scanner

Take that CB off the shelf, good buddy! Here's how to use your computer to scan the channels you select, and without having to flip the switch! **Frank P. Maloney**

## 11 Soup Up Your PC

Here's how to change chips and get yourself some turbocharged performance with as much as a 30% improvement. **TJ Byers**

## 14 Optical Disks

In the near future, those compact discs now used in classy stereo equipment may be finding their way into your computer system where they'll be doing yeoman service as storage devices. **Marc Stern**

## 3 Editorial

## 4 Letters

## 4 Computer Products

## 5 Software Review

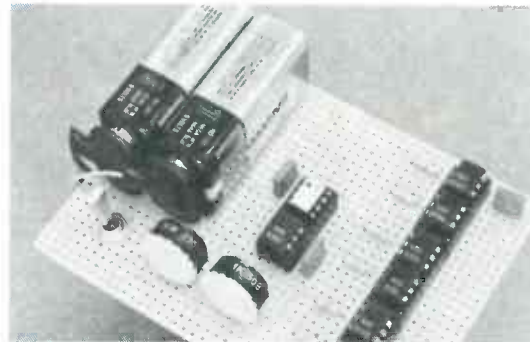

See Page 7

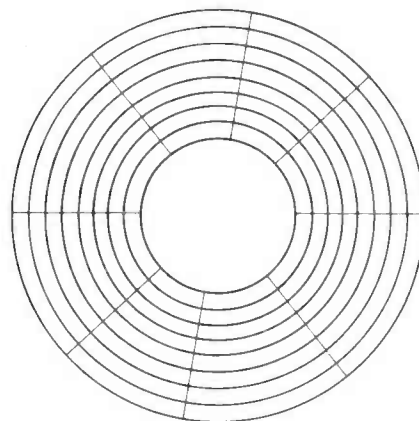

See Page 14

## ON THE COVER

You can make your PC perform like the beautiful IBM PC/AT shown on this month's cover. For full details, see the article that starts on page 11 or buy one of the new ones from IBM!

## COMING NEXT MONTH

Man, have we got a fantastic line-up for you! We're kicking off this issue with a Graphic Biofeedback monitor that does everything but feed you tranquilizers. Then there's a TVRO antenna pointer that gives you all the numbers via computer. Finally, you'll find a story on how to upgrade your Okidata printer. Don't miss it.

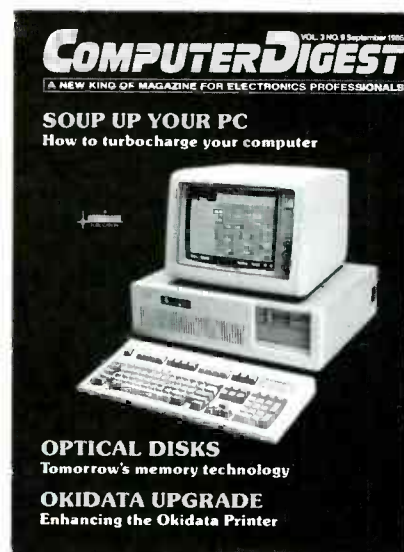

# EDITORIAL

## Told ya so!

■The shaking-out period is just about over. For awhile back there, "computer" was a magic word that opened the bank. If you had a computer-oriented product, you automatically made lots of money. Opportunists the world over jumped on the bandwagon just as they did when "stereo" was the magic word, or "CB."

And of course, magazines sprung up like weeds. Some long-established publications in the electronics industry changed their direction to cater to the new interest. At least one went so far as to change its name. So-called "vertical" publications appeared to cater to the purchasers of a particular brand of computer. Newsletters appeared all over the place to cater to particular interests. And people who had never before been in the publishing business now saw reason to give it a try.

Gernsback Publications, a long-established force in the communications industry, took a different tack. **ComputerDigest** Magazine was brought out as a 16-page insert in the well-established **Radio-Electronics** Magazine. Readers who had long-subscribed to this publication, began to worry and wonder. Mail poured in from concerned readers who did not want the tail to wag the dog. Was their favorite magazine going to follow the others and become another Computer Magazine? Were more and more pages to be given over to computers until a full transition had been made?

We assured the readers that this would never be the case, and told them not to be concerned.

**ComputerDigest** is now in its third year. It still occupies only 16 pages, at no cost to the space allocated for **Radio-Electronics**.

As we said at the start of this editorial, the shaking-out period is about over. The many new businesses and new magazines that offered little more than another place to spend your money have dropped by the wayside. Those who are still in business will, no doubt, remain in business.

We're glad we're still here.

We told you!



Byron G. Wels  
Editor

**ComputerDigest** is published monthly as an insert in **Radio-Electronics** magazine by Gernsback Publications, Inc., 500-B Bi-County Blvd., Farmingdale, N.Y. 11735. Second-Class Postage Paid at New York, N.Y. and additional mailing offices. Copyright © 1986 Gernsback Publications, Inc. All rights reserved. Printed in U.S.A.

A stamped self-addressed envelope must accompany all submitted manuscripts and/or artwork or photographs if their return is desired should they be rejected. We disclaim any responsibility for the loss or damage of manuscripts and/or artwork or photographs while in our possession or otherwise.

# COMPUTER DIGEST

M. Harvey Gernsback,  
editor-in-chief, emeritus

**Larry Steckler,**  
EHF, CET: publisher & editor in chief

**Art Kleiman,**  
editorial director  
**Byron G. Wels,**  
editor  
**Brian C. Fenton,**  
managing editor  
**Carl Laron,**  
associate editor  
**Robert A. Young,**  
assistant editor  
**Ruby M. Yee,**  
production director  
**Karen Tucker,**  
production advertising  
**Robert A. W. Lowndes,**  
production associate  
**Geoffrey S. Weil,**  
production assistant  
**Andre Duzant,**  
technical illustrator  
**Jacqueline P. Cheeseboro**  
circulation director  
**Arline R. Fishman,**  
advertising director

Computer Digest  
Gernsback Publications, Inc.  
Executive offices  
500-B Bi-County Blvd.,  
Farmingdale, NY 11735  
516-293-3000  
President: Larry Steckler  
Vice President: Cathy Steckler

**ADVERTISING SALES 516-293-3000**  
Larry Steckler  
Publisher

**NATIONAL SALES**  
Joe Shere  
1507 Bonnie Doone Terrace  
Corona Del Mar, CA 92625  
714-760-8967

# LETTERS

writing, we've got an author work on an article covering that subject. Keep an eye on **ComputerDigest**.

## Hookup

How can I adapt my Sinclair so I can plug it directly into a composite video monitor instead of using a TV set? How do you bypass the RF modulator?—J.D., Methuen, MA.

*At the very moment of this*

## Users' Group

A new international word processing users' group has been formed. It offers a bi-monthly newsletter, called SCROLL and we're planning our own national bulletin board system. A complete

telecommunications package will be offered to all members. And a library of public domain and tutorial disks in over 100 different computer formats will be available to members. Cost is just \$15.00 per year annual membership. Write to W/PUG, Box 144, Malverne, NY 11565 or call me at (516) 746-0056.

Could you give us a "plug" in **ComputerDigest** Magazine?—A.G., Malverne, NY.

*No AI, sorry. We don't do that.*

## Help!

I don't know a thing about computers, but my new secretary told me our old typewriter is passe. I was ready to buy a new one, but she suggested either a computer or at least an electronic typewriter. I don't want to invest heavily and then find that massive training programs are required. What's your recommendation?—L.M., Great Neck, NY.

*Go for the computer! (What else would I say?) Make sure you get a letter-quality printer with it and a good word processing program. Give her the instruction manual over a weekend, and when she comes in on Monday morning, stand back! The efficiency and throughput will floor you.*

## Danger?

My father tells me that there's a hazard of radiation exposure if I spend time in front of the VDT (Video Display Terminal). I say he's getting as much exposure from the TV set he's watching.—FS., Detroit, MI.

*Try an experiment: Get some X-Ray film from your dentist, wrap one piece in lead foil as a control. Tape another piece to the CRT screen of your terminal, another to the TV screen. Rig another piece a foot away from each screen, still another two feet away. Keep 'em in place for a week, then have them all developed. making sure they're numbered so you know which was where. With a densitometer or photographic light meter, you'll get relative indications of the exposure and the rate of decay of each through free space. Let us know how you make out!*



- **Dual Inputs** — measure two temperature sources, switch-selectable
- **Differential and Normal Temperature Modes** — automatically read the difference between two temperatures or each separately. Provides for accurate relative temperature determinations. Ideal for heating and air conditioning service and environmental monitoring
- **DC Millivolt Range** — quick check of thermocouples, flame rods and other sensors
- **Chart Recorder Output** — provides 1 mV DC per degree F or C output with low source resistance for recording/controlling applications
- **Four Ranges:** -30°F to +200°F and +200°F to +1200°F  
-34°C to +93°C and +93°C to +650°C
- **High Accuracy** — 0.2% of reading + 1°C (1.8°F), from 0°F to +1000°F
- **Switch-Selectable Centigrade or Fahrenheit Readout**
- **Large, High-Contrast, 0.5" Liquid Crystal Display**
- **Single 9 Volt Alkaline Battery**
- **Humidity Kit, Disposable Thermocouples and Other Accessories Available**

**Model 383**, complete with test lead set, 4' J-type temperature sensor probe, 9 V alkaline battery and operator's manual, Cat. No. 12415 **\$195.00**

AVAILABLE FROM LEADING ELECTRONICS/ELECTRICAL DISTRIBUTORS



**SIMPSON ELECTRIC COMPANY**

853 Dundee Avenue, Elgin, Illinois 60120-3090  
(312) 697-2260 • Telex 72-2416 • Cable SIMELCO

CIRCLE 206 ON FREE INFORMATION CARD

# COMPUTER PRODUCTS

For more details use the free information card inside the back cover

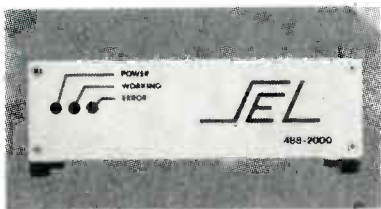

CIRCLE 18 ON FREE INFORMATION CARD

**UNIVERSAL INTERFACE**, the model 488-2000, is a GPIB-488 interface for all IBM PC, IBM XT, IBM AT, IBM CLONES, Apple Macintosh, Tandy 3000, 2000, 1200HD, and 1000. It can be used with any computer having RS232, and with any language having access to RS232 port (BASIC, Pascal, C). It can also be used with assembler or machine code.

The baud rate is 300, 600, 1200, 2400, 4800, and 9600; size is 7.5" x 2.25" x 5", and the power requirements are 105-125 volts AC, 60 Hz.

The model 488-200 is priced at \$675.00.—**Scientific Engineering Laboratories, Inc.**, 104 Charles Street, Suite 143, Boston, MA 02114.

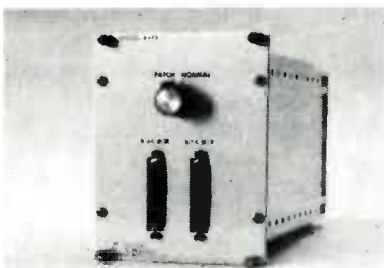

CIRCLE 19 ON FREE INFORMATION CARD

**PATCH & MONITOR MODULE**, the model 9179 allows the user to monitor signals at the high-speed data interface and reconfigure the interconnection between modems and terminals when equipment malfunction occurs or data-path re-routing is required.

The model 9179 V.35 module is connected in series between each V.35 modem and its associated data-terminal equipment. When switched to normal, the modem and terminal are connected together, and their interface signals are accessible at a front-panel connector for monitoring by a data-link analyzer. If equipment malfunction is detected, the module may be switched to its patch mode. When switched to patch, the modem and terminal connection is broken and all signals are routed to the front-panel con-

nectors, thereby allowing a patch connection to back-up equipment while repairs are being made. Up to four modules slide into a standard 19" module rack. Delivery is from stock.

The model 9179 is priced at \$229.00.—**Electro Standards Laboratory, Inc.**, PO Box 9144, Providence, RI 02940.

**XT-COMPATIBLE COMPUTER**, has all the features of an IBM PC/XT, such as: 256K RAM memory, 8 full expansion slots, 135-watt power supply, floppy-disk controller board—up to 4 drives, full-function keyboard, 360KB 48TPI floppy-disk drive, high-resolution monochrome monitor, monochrome



CIRCLE 20 ON FREE INFORMATION CARD

graphics card w/printer port, and BIOS compatible with IBM PC/XT. The complete system is FCC-approved.

Many add-on options are available, such as 640KB mother board; 10, 20, and 40 MB disks; RGB monitors; tape back-up systems; color graphics board; hard-disk controller board, and color monitors. The price of the complete system (not including add-ons) is \$999.00.—**Sintec Company**, 28 Eighth St., Box 410, Frenchtown, NJ 08825.

**FINANCIAL PLANNER**, is the Commodore 128 computer version of "Sylvia Porter's Personal Financial Planner." The user is taken step-by-step through a series of questions that will help him or her develop comprehensive plans to determine the best financial moves for his or her career, marital status, savings, life insurance,



CIRCLE 21 ON FREE INFORMATION CARD

investments, life style, retirement, and estate. The user can also plan ahead for protection against major medical expenses, prolonged disability, and other possible adversities.

The program also includes electronic checkbook and checkwriting, budget preparation, tax aids, financial-statement preparation, and financial-inventory tracking.

The suggested retail price for the *Financial Planner* is \$129.95 for the IBM; \$99.95 for Apple; \$69.95 for the Commodore 128, and \$59.95 for the Commodore 64.—**Timeworks**, 444 Lake Cook Road, Deerfield, IL 60015.

**LIGHT PEN**, the *Feather*, is cordless, fully self-contained, and lightweight. Typical uses include rapid data-entry and retrieval in medical settings, CAD



CIRCLE 22 ON FREE INFORMATION CARD

design of a new mechanical part, and high-speed manipulation of business spread-sheets. It uses an infra-red communications link, powered by commonly available batteries.

The *Feather* is priced at \$195.00.—**Hei, Inc.**, Victoria, MN 55386.

# SOFTWARE REVIEW

## *MINI-JINI—A record keeper for the Commodore 64.*

■ There are probably more 64's in use than any other personal computer. It's difficult to say how many, but depend on it, the numbers are really up there. Mostly, it's used for games because the software required for business applications is beyond the convenience or capability of the 64's slow cassette and disk storage systems. If used with software that allows and compensates for this slowness, the 64 can be a sparkling performer. Such a program is MINI JINI, an in-memory record keeping system attractive to hobbyists, technicians and small service shops because it's easy to use, easy to set up and provides a convenient way to computerize a modest-size customer file or inventory, mailing list or just substitute for a 3 × 5 file card index. It's extremely versatile.

MINI JINI is a data filing system that organizes data into customized reports. The program stores related data in individual records, each consisting of a list of up to ten related items called "fields" such as name, date, telephone, etc. A field can have any kind of format or content, as long as several characters required by the program itself aren't used, such as the comma, colon or quotation mark. One of the fields can even store data created from other fields through an internal function called MATHPACK, which performs calculations on the whole file, letting the user add, subtract, multiply or divide two fields or a field and a constant. MathPack functions include: Add a constant, add two fields, subtract a constant, subtract two fields, multiply a constant, multiply two fields, divide a constant, divide two fields, sum and average.

While each record can be 800 characters, an individual field length is limited to two complete lines (80 characters), and unused characters in one field cannot be used in another field. 80 characters is the absolute maximum for any field. Since all data is within the RAM the total number of records per file depends on the individual record size(s). If a data file gets too large for the 64's RAM it must be split and stored on cassette or disk as two separate files.

As each record is entered into RAM, MINI JINI assigns a sequential number which is not used unless changing or deleting a record. If a record is deleted, the program closes the gap, renumbers the records, and frees the RAM for other records.

The entire file can be scanned to view data. Specific data can be found through GLOBAL SEARCH through the entire database, or FIELD SEARCH which looks through a specified field. The actual search is rapid because the entire database exists in memory and nothing is faster than reading RAM. To view or print data in a specified sequence, records can be alphabetized in ASCII for any given field. For example, a file might be ordered by customer's last name, by Zip, or by the date on which you last serviced.

Unlimited updating is possible simply by overtyping the screen display. When this is entered as a "changed record," it substitutes for the RAM record. It is likewise possible to selectively delete data for a particular field or the entire record.

The PRINT FILE mode provides hardcopy for a record or up to four lines from any user-selected fields on standard 1<sup>5</sup>/<sub>16</sub> inch mailing labels. And fields can be printed in any desired order.

A WRITE-A-FILE mode writes data to tape, disk or a printer, even a modem with the correct modem hard and software. A READ mode, similarly, reads data from tape or disk.

MINI JINI is supplied as a ROM cartridge that resembles and works like a standard game cartridge. Just plug it in and the program comes up running with a logo that changes to a menu. All functions and operating modes including an initial selection of screen colors are menu driven and all modes provide a means for returning to main menu should something go wrong or if you change your mind. No entries become permanent until entered by the user.

MINI JINI is not in the same class as a sophisticated data-management system with unlimited storage capacity and reporting formats. It does provide a way to store and access moderate amounts of information. Keep in mind that loading data from tape or disk still takes time. It required almost six minutes to load a file of 85 ten-field records. The program runs fast only when the data is in RAM, not when loading or unloading.

MINI JINI is sold by JINI Micro Systems, Inc., Box 274, Riverdale, NY 10463. ◀▶

CIRCLE 17 ON FREE INFORMATION CARD



# COMPUTER CB SCANNER

*How to use your computer  
to scan the CB channels*

**Dr. Frank P. Maloney**

■ Although the CB craze seems to be over, there continues to be a great deal of activity on the channels. In fact, now that the first rush has passed, activity seems to have become more serious. Fire up your transceiver, and you'll find social groups using the inexpensive conference-call, REACT on channel 9, your neighborhood townwatch, security at civic and sports events, hobbyists, local paging, and of course, the channel 19 circus. While your interest may be piqued, I suspect that you will soon rediscover why you abandoned CB in the first place. We grow weary of constantly flipping that 40-channel switch looking.

## **Use the computer**

How much more convenient it would be if, using a home computer, we could directly access any channel from the computer's keyboard, or step through the channels one-at-a-time, or rapidly display the activity on all 40 channels (like an oscilloscope) or even scan a pre-set group of channels, stopping on one of them when there is activity (like a scanner)? If you have a recently-manufactured CB that uses a phase-locked

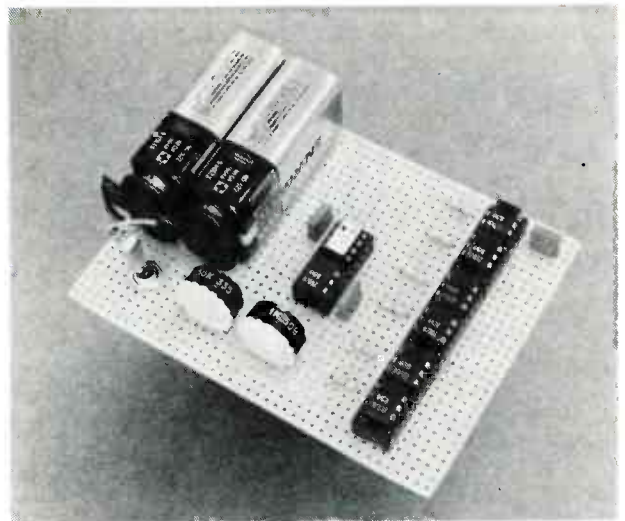

**THE COMPLETE CIRCUIT, ready for installation and use. Wire wrap techniques were used by author, on perf board.**

loop integrated circuit (PLL IC) synthesizer instead of individual crystals, and a home computer, the above features are simple to implement. And if yours is a Commodore C64, SX64 or C128 computer, the programs are already written for you.

Locate the schematic diagram of your CB transceiver, or open the unit up and take a look around. Make sure you disconnect it from the power source first. Near the 40-channel selector switch, will be the PLL IC. Chances will be good that it is a type LC7131, used in many Cobra and Radio Shack units. Should it *not* be a 7131, don't worry. Although I will be describing the 7131, the basic principles are the same for all PLL IC's.

Note that there are six lines going from the selector switch to pins 1 through 6 of the 7131 chip. These lines contain the binary-coded decimal (BCD) value of the channel number, and hold the unit's digit, lines 5 and 6 hold the tens digit. As an example, channel 23 is coded:

PIN 65:4321 : DATA 10:0011 : CHANNEL 2: 3

Channel 40 is an exception, it is coded all zeroes. A data 1 means about 9 volts on that pin, a data zero is

about 0 volts. So there is the plan, set the selector switch to channel 40, and have a home computer's peripheral port control these lines to select the desired channel. Then have the computer "read" the S-meter with the game paddle port. Any home computer will do, as long as it has a peripheral port and a game port that you can control.

### Other chips?

If you found other chips than the 7131, such as the uPD2824 or the LC7132 used in some Radio Shack units, you're still in business. The 2824 is almost identical to the 7131. The 7132 uses 8 lines instead of 6 to control the channel, so the coding will be different from what I have previously described. Spend a few minutes with a voltmeter, and by changing the selector switch while you test pin voltages, you can figure out the coding for most any PLL IC.

Look at interface circuit, Fig. 1., showing the optocoupling to pins 1 through 6 on the 7131 PLL IC. A data zero on the cathode of optocoupler OC1 allows

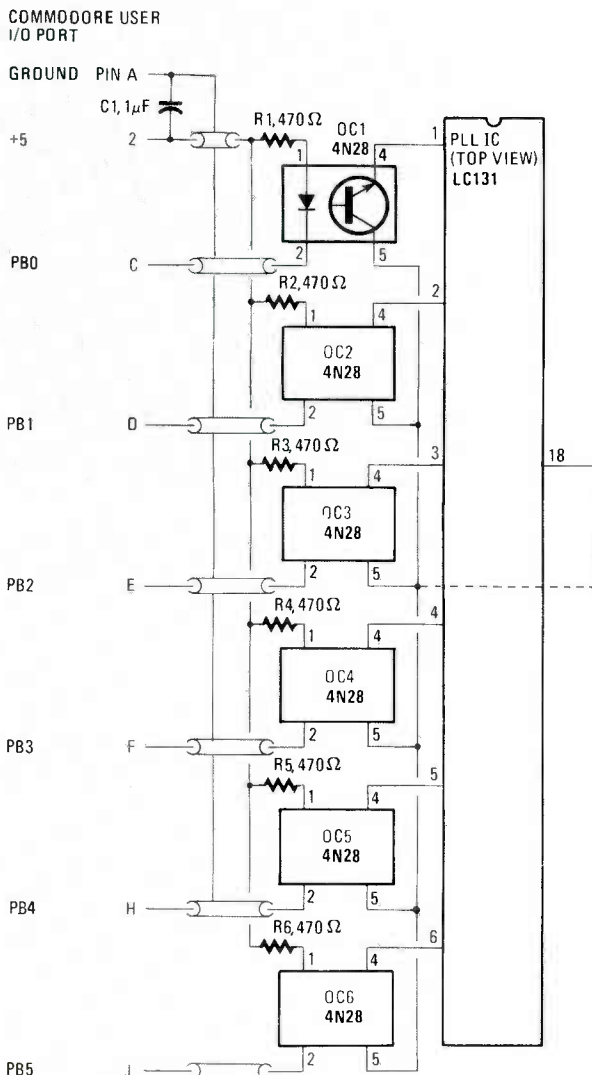

FIG. 1—SCHEMATIC DIAGRAM of the interface circuit, linking computer's peripheral port to the PLL IC in a CB transceiver.

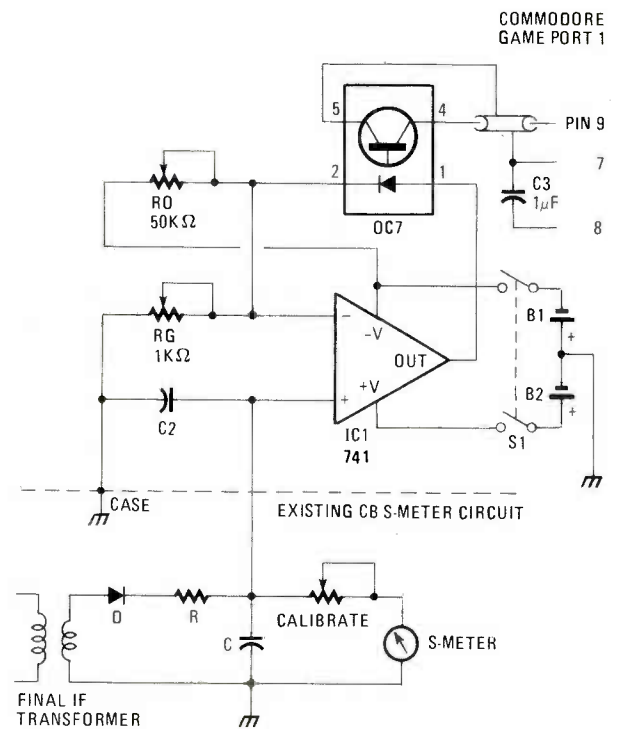
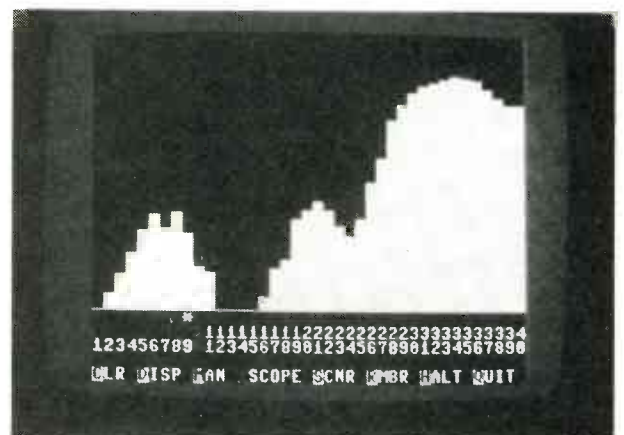

FIG. 2—S-METER buffer amplifier interface circuit is shown here schematically.

current to flow from the +5 volt supply from the computer into the peripheral port (PBO on the Commodore). That turns the transistor on, allowing current to flow from pin 18 to pin 1 of the PLL IC, placing a data 1 there. The 6 optocouplers are required to isolate the computer's from the transistor's differing voltages, as well as to prevent the RF hash from the computer from interfering with CB reception. Even so, be sure to use shielded cable from the peripheral port to the optocouplers, as shown in the schematic.

The S-meter level is communicated to the computer's game paddle input by a simple 741 op-amp and another optocoupler. The circuit is shown in Fig. 2. A typical S-meter circuit consists of a diode detector on the final IF transformer, and a smoothing



THE COMPUTER MONITOR, showing display of activity plotted vertically on the 40 channels. Observe the bleed-over on channel 8 to adjacent channels caused by overmodulation.

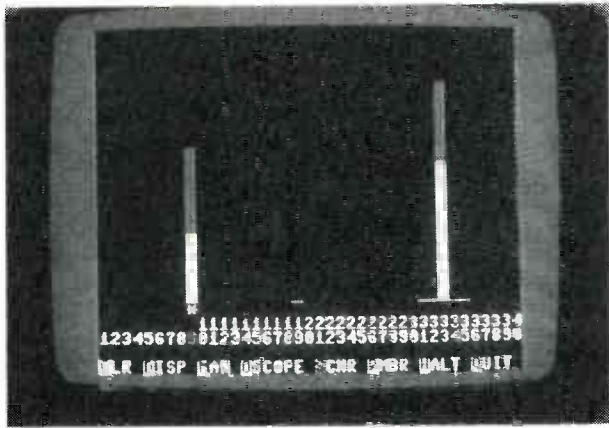

**VERTICAL PLOT OF ACTIVITY ON CHANNEL 15** plotted as a function of time (horizontal). A transmitter has just keyed up. Notice the overshoot of the receiver's automatic gain control (AGC).

filter, R and C. The attack time constant is  $T = RC$  seconds (without  $C_2$ ). We sample the voltage V on C with the op-amp, which forces a current  $i = V/R_g$  through the optocoupler diode. Thus, trimpot  $R_g$  sets the gain of the circuit. Offset current is provided by trimpot  $R_o$ . These gain and offset levels will be set later so the range S1 through S9 + 30 dB on your S-meter results in the correct display range on your computer. Also,  $C_2$  must be chosen so that T is about twice as long as the digitization speed of the computer's paddle port. For the Commodore, a reading is completed every 512 phase-two cycles, about 0.0005 second. So choose  $C_2$  so that  $T = RC + C_2 = 0.001$  second. If you cannot determine R and C for your CB, a good value to try is 1 microfarad. The resulting current through the optocoupler diode varies the resistance between the collector and the emitter of the transistor, functioning like a variable resistance paddle. That resistance is digitized by the computer.

The cost of these materials is less than \$15., depending on how fancy an enclosure you buy. You can use simple point-to-point wiring on perf board. Wire wrap is particularly easy with the IC socket pins, and these can be tack-soldered to the foil side of your CB. You can tap the S-meter voltage between C and

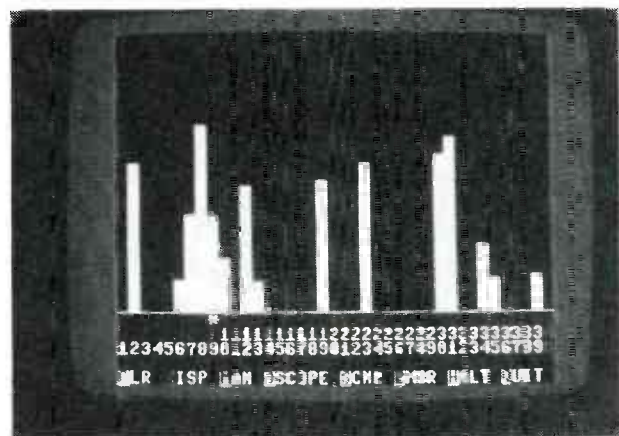

**ACTIVITY PLOTTED VERTICALLY on channel 10** against time (horizontal). A distant transmitter is seen facing in and out, indicating poor skip conditions.

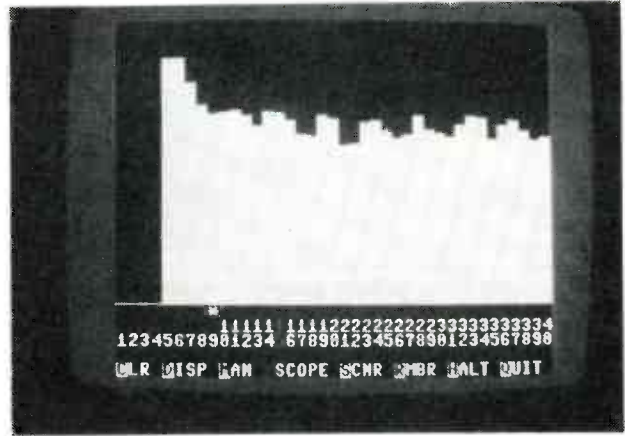

**SCANNER OPERATION.** Channels 9, 19, and 31-35 have been programmed. Channel 33 was last active, but has timed out. Channel 9 is presently being monitored.

transceiver ground, from the C-side of R or the calibrate trimpot.

#### PARTS LIST

##### Semiconductors

OC1 - OC7—4N28 Optocouplers  
IC1—741 Op-Amp

##### Resistors

(All resistors 1/8 watt, 10% unless otherwise specified)  
R1 - R6—470 ohms  
 $R_g$ —1000 ohm gain trimpot  
 $R_o$ —50,000 ohm offset trimpot

##### Capacitors

C1, C3—1 $\mu$ F ceramic, 50V  
C2—See text

##### Miscellaneous

B1, B2—9-volt batteries  
S1—DPST or DPDT switch  
24-pin female edge connector for Commodore I/O port, 9-pin DB9 female connector for Commodore game I/O port, enclosure, shielded microphone cable, IC sockets.

#### The software

Once you have the circuit working properly, you will need to work on the software. Initially, you can use simple POKE's and PEEK's from BASIC to see if the coding for the PLL IC is correct. A complete program should enable you to:

- directly access any channel by using the keyboard digits
- step up or down a channel at a time
- display the activity on any all 40 channels
- display, in oscilloscope fashion, the activity on a channel
- scan a programmable set of channels, stopping to monitor whenever the activity exceeds a threshold.

If you have a Commodore computer and wish to avoid re-inventing the wheel, I can send you a machine language routine which implements the above functions. Just send a *new, formatted* but otherwise *blank* diskette with your name and address *on the disk* and a sturdy, stamped, self-addressed envelope to: Dr. F. P. Maloney, Department of Astronomy and Astrophysics, Villanova University, Villanova, PA 19085. The disk and full operating instructions will be returned to you. ◀▶

# Electronics Paperback Books

EVERY BOOK IN THIS AD \$5 OR LESS!

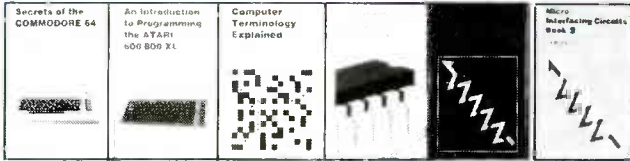

- BP125—25 SIMPLE AMATEUR BAND ANTENNAS.....\$5.00.** All are inexpensive to build, yet perform well. Diodes, beams, triangle and even a mini rhombic.
- BP 128-20 PROGRAMS FOR THE ZX SPECTRUM & 16K ZX81.....\$5.00.** Programs to run. Programs to have fun with. Even programs that will help you learn to write programs.
- 160—COIL DESIGN & CONSTRUCTION MANUAL.....\$5.00.** How the hobbyist can build RF, IF, audio and power coils, chokes and transformers. Covers AM, FM and TV applications.
- 208—PRACTICAL STEREO & QUADROPHONY HANDBOOK.....\$3.00.** A reference book for all interested in stereo and multichannel sound reproduction.
- 214—AUDIO ENTHUSIAST'S HANDBOOK.....\$3.50.** Explains record/playback curves, stylus compliance, how we evaluate loudness, how compatible is compatible, and more.
- 219—SOLID-STATE NOVELTY PROJECTS.....\$3.50.** Fun projects include the Optimin, a musical instrument that is played by reflecting a light beam with your hand, and many more.
- 222—SOLID STATE SHORT WAVE RECEIVERS FOR BEGINNERS.....\$4.50.** Modern solid-state circuits that will deliver a fairly high level of performance.
- BP126—BASIC & PASCAL IN PARALLEL.....\$4.25.** Takes these two programming languages and develops programs in both languages simultaneously.
- 224—50 CMOS IC PROJECTS.....\$4.50.** Includes sections on multivibrators, amplifiers and oscillators, trigger devices, and special devices.
- 225—A PRACTICAL INTRODUCTION TO DIGITAL IC'S.....\$4.25.** Mainly concerned with TTL devices. Includes several simple projects plus a logic circuit test set and a digital counter timer.
- 226—HOW TO BUILD ADVANCED SHORT WAVE RECEIVERS.....\$5.00.** Full practical construction details of a number of receivers are presented.
- 227—BEGINNERS GUIDE TO BUILDING ELECTRONIC PROJECTS.....\$5.00.** How to tackle the practical side of electronics so you can successfully build electronic projects.
- BP6—ENGINEERS AND MACHINISTS REFERENCE TABLES.....\$2.00.** Screw thread data, drill sizes, circle division, angles, tapers and more.
- 123—FIRST BOOK OF PRACTICAL ELECTRONIC PROJECTS.....\$3.75.** Projects include audio distortion meter, super FET receiver, guitar amplifier, metronome and more.
- BP24—52 PROJECTS USING IC 741.....\$4.00.** Lots of projects built around this one available IC.
- BP32—HOW TO BUILD YOUR OWN METAL & TREASURE LOCATORS.....\$5.00.** Electronic and practical details on the simple and inexpensive construction of hetrodyne metal locators.
- BP33—ELECTRONIC CALCULATOR USERS HANDBOOK.....\$5.00.** Invaluable book for all calculator owners. Tells how to get the most out of your calculator.
- BP36—50 CIRCUITS USING GERMANIUM, SILICON & ZENER DIODES.....\$3.75.** A collection of useful circuits you'll want in your library.
- BP37—50 PROJECTS USING RELAYS, SCR'S & TRIACS.....\$5.00.** Build priority indicators, light modulators, warning devices, light dimmers and more.
- BP39—50 FET TRANSISTOR PROJECTS.....\$4.50.** RF amplifiers, test equipment, tuners, receivers, tone controls, etc.
- BP42—SIMPLE LED CIRCUITS.....\$4.25.** A large selection of simple applications for this simple electronic component.
- BP43—HOW TO MAKE WALKIE TALKIES.....\$5.00.** Equipment for low-power hand-held or portable operation.
- BP45—PROJECTS IN OPTOELECTRONICS.....\$5.00.** Includes infra-red detectors, transmitters, modulated light transmission and photographic applications.
- BP48—ELECTRONIC PROJECTS FOR BEGINNERS.....\$5.00.** A wide range of easily completed projects for the beginner. Includes some no-soldering projects.
- BP49—POPULAR ELECTRONIC PROJECTS.....\$4.75.** Radio, audio, household and test equipment projects are all included.
- BP51—ELECTRONIC MUSIC AND CREATIVE TAPE RECORDING.....\$5.00.** Shows how you can make electronic music at home with the simplest and most inexpensive equipment.
- BP56—ELECTRONIC SECURITY DEVICES.....\$5.00.** Includes both simple and more sophisticated burglar alarm circuits using light, infra-red, and ultrasonics.
- BP59—SECOND BOOK OF CMOS IC PROJECTS.....\$4.25.** More circuits showing CMOS applications. Most are of a fairly simple design.
- BP72—A MICROPROCESSOR PRIMER.....\$4.50.** We start by designing a small computer and show how we can overcome its shortcomings.
- BP78—PRACTICAL COMPUTER EXPERIMENTS.....\$4.50.** Construct typical computer circuits using discrete logic to form a basic understanding of how computers function.
- BP91—AN INTRODUCTION TO RADIO DXING.....\$5.00.** How you can tune in on those amateur and commercial broadcasts from around the world in the comfort of your home.
- BP94—ELECTRONIC PROJECTS FOR CARS AND BOATS.....\$5.00.** Fifteen simple projects that you can use with your car or boat. All are designed to operate from 12-volt DC supplies.

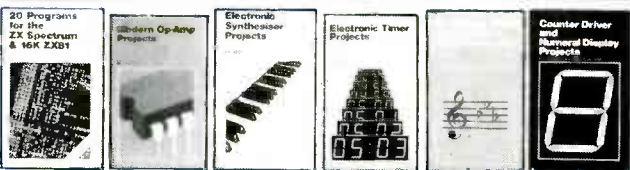

**ELECTRONIC TECHNOLOGY TODAY INC.**  
P.O. Box 240, Massapequa Park, NY 11762-0240

SHIPPING CHARGES IN USA & CANADA

\$0.01 to \$5.00	..... \$1.00
\$5.01 to \$10.00	..... \$1.75
\$10.01 to \$20.00	..... \$2.75
\$20.01 to \$30.00	..... \$3.75
\$30.01 to \$40.00	..... \$4.75
\$40.01 to \$50.00	..... \$5.75
\$50.01 and above	..... \$7.00

**OUTSIDE USA & CANADA**

Multiply Shipping by 2 for sea mail  
Multiply Shipping by 4 for air mail

Number of books ordered

Name \_\_\_\_\_  
Address \_\_\_\_\_  
City \_\_\_\_\_ State \_\_\_\_\_ Zip \_\_\_\_\_

Total price of merchandise ..... \$ \_\_\_\_\_  
Sales Tax (New York State Residents only) ..... \$ \_\_\_\_\_  
Shipping (see chart) ..... \$ \_\_\_\_\_

**All payments must be in U.S. funds**

Total Enclosed . \$ \_\_\_\_\_

RE9-86

# SOUP-UP YOUR PC

Add punch to your IBM PC.

T J Byers

■While it is rumored that the new super-microprocessor chips, such as Intel's 80386, are going to revolutionize the personal computer, some think there is more than enough power in the architecture of the popular 8086 microprocessor to keep the computer industry satisfied for some time to come.

In the wake of claims for chips with mainframe power, NEC Electronics has taken the venerable 8086 and given it more punch. The new design, the V30, promises to improve system performance by 25 to 30 percent. And, this achieved inside the chip so no changes to the computer system are required.

## Microprocessor architecture

The secret to this turbocharged performance lies in the architecture of the new chip. Unlike the 8086, which uses a single 16-bit internal bus, the NEC microprocessor uses an advanced interface controller that feeds two internal buses. Fewer ticks of the clock process the data as operations can be divided into two groups and run simultaneously.

To understand how, we must learn how microprocessors work. The microprocessor is divided into five sections, as illustrated in Fig. 1. Each division performs a function that affects the operation of another part of the internal microprocessor system.

First is the I/O interface bus, which stands between the internal structure of the chip and the outside world. It translates incoming and outgoing signals into voltages that are compatible with both sides of the system.

Steering the I/O interface is a bus interface controller. This is the traffic cop. It tells the data which way to go and when. The bus interface controller contains five on-board memory cells called registers. Each register holds 16 bits of user-inputted binary data used to coordinate the operations of the controller.

Beyond the bus interface controller is the microprocessor itself. It is composed of three parts: a microcode ROM (Read-Only Memory), an arithmetic logic unit (ALU), and the data registers.

Processing data through the microprocessor consists of entering the data into one or more of the data registers and performing an operation on it. The ALU is the engine which manipulates the data. Coordinating the effort is the microcode ROM.

If we have two numbers that we wish to add, we begin by telling the microprocessor that the next

operation will be addition. The ROM looks up a table that contains all the instructions necessary to derive the sum of two numbers. These are the microcodes. For addition, three microcode instructions are needed. The process goes something like this.

First, fetch the number from register A, pass it through the internal bus, and place it in the ALU. Second, fetch the number from register B, pass it through the internal bus, and place it in the ALU. Third, add the two together and place the sum in register A using the internal bus. Each instruction requires one tick of the clock. If a clock pulse occurs every microsecond, it will take three microseconds to tally the two numbers. Multiplication and division are much more complicated because more steps are involved. To multiply a number by 10, for example, the base number must be added to the sum ten times. It is not uncommon to see functions requiring hundreds of microcoded instructions. Remember, each instruction uses one clock cycle, and the longer the microcode, the longer it takes to execute the command.

## Take the "A" bus

Each instruction of our example used the internal bus for part of its operation. This is not unusual. In fact, most microcode instructions make use of the internal

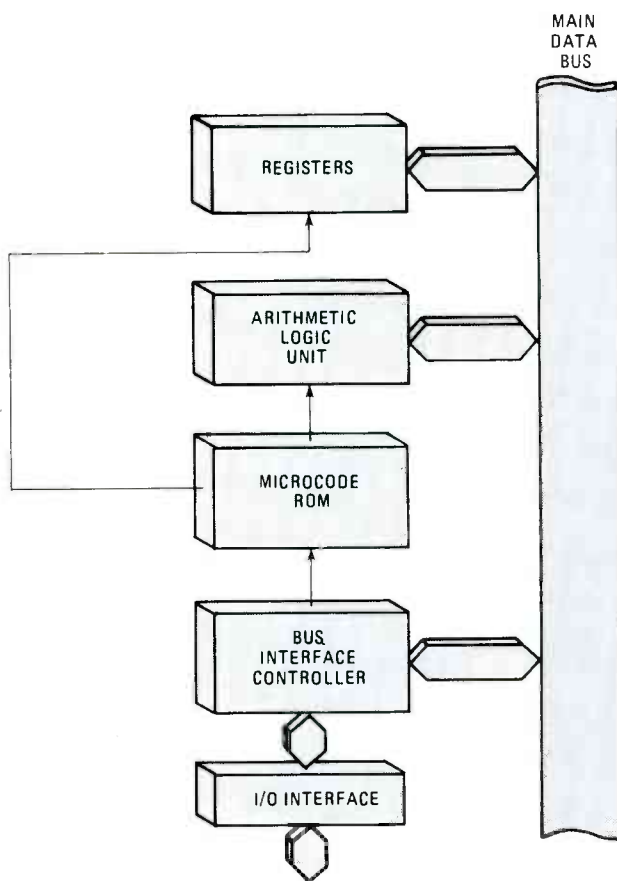

Fig. 1—THE 8086/8088 MICROPROCESSOR is divided into five sections. Each division performs a function that controls or affects the operation of another part of the internal microprocessor system. Data within the chip is passed from function to function through a single 16-bit wide main data bus.

bus in one way or another.

The internal bus is the data link between the elements of the processor. Before bus technology, all data was treated serially, with each bit passing through each element one bit at a time. The bus allows data to be routed in parallel, which improves throughput.

Unfortunately, the bus can pass only so much data at a time, depending on its width. If the bus is 8-bits wide, then it can transfer a byte at a time. A 16-bit bus can pass two bytes, etc. Designers realized that to get more done, the bus would have to be made wider, and current trends are towards a 32-bit bus, such as the one Intel is developing for its 80386 super-computer chip.

Present day personal computers, however, use either an 8-bit or 16-bit bus, so a major redesign is necessary before the new 32-bit microprocessors can be used.

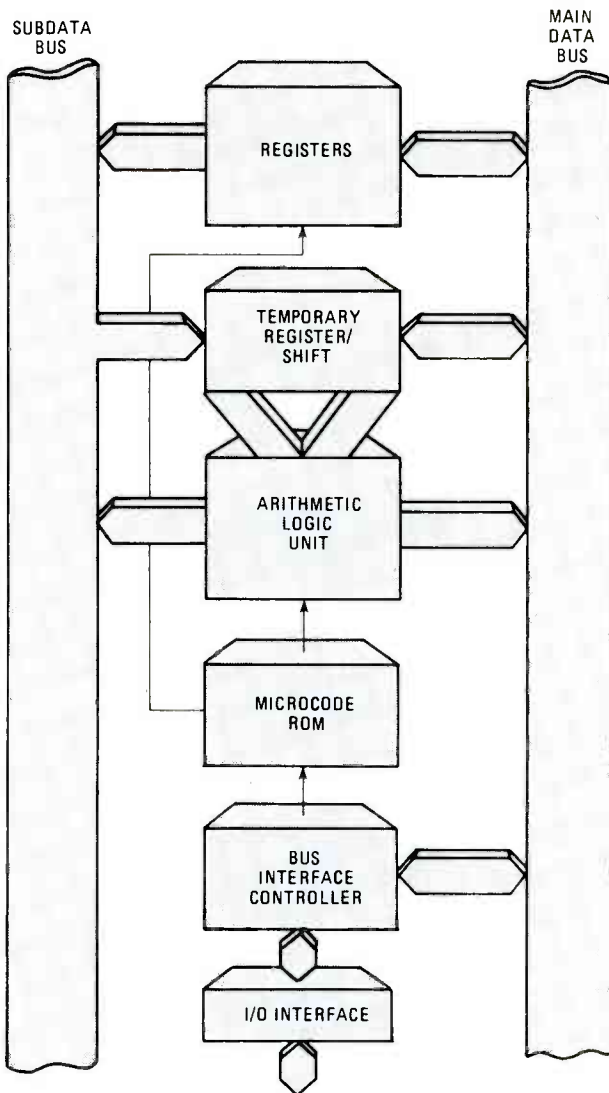

**Fig. 2—IN THE DUAL BUS METHOD, such as supported by NEC's V20 and V30, there is a main data bus and a subdata bus. Data is passed through the main bus for all main input and output operations. Concurrently, internally-routed data may be passed through the subdata bus, thus improving data throughput.**

### Add the "B" bus

There is another way to do more. We can leave the bus as is and add a second internal bus to the structure. This is what NEC has done in the V30.

In the dual-bus method, there is a main data bus and a subdata bus, as outlined in Fig. 2. Data is passed through the main bus according to the needs of the microprocessor. In addition, data may be concurrently passed through the subdata bus in a similar fashion. The result is a greater throughput of data.

Let's refer to our previous example. Like the single bus method, the microcode ROM contains the instructions for the operation—addition. This time, only two instructions are necessary to derive the sum of two numbers. It goes as follows.

First, the number contained in register A is passed to the ALU through the main data bus. At the same time, the number contained in register B is passed through the subdata bus and loaded into the ALU. This operation requires one microcode instruction, and one tick of the clock. Second, the numbers are summed and the result is passed through the main data bus to register A. The entire process takes two clock cycles.

We have increased the speed of the microprocessor by 33 percent, without modification to the clock or the external I/O interface. The new chip is compatible with the old chip. All modifications to the system are internal and not apparent to the user or the computer system.

### A new chip in an old package

If this was all NEC did to enhance the 8086, it would still be a significant improvement. But since the internal architecture was being redesigned anyway, it wasn't that difficult for NEC to enhance it further.

To further improve performance, NEC added two temporary shift registers to the internal structure. Each register is 16-bits wide. These registers are attached directly to the ALU and actually become an extension of the ALU. Whencascaded, these registers serve as immediate data storage that provides speedier multiplication and division operations because the data doesn't have to travel through the data bus but twice: Once to load the registers and once to unload them.

The second register, when split from the first, can be used to hasten shift and rotate functions. The register is actually a part of the ALU, and fewer microcode commands are required per function. And, NEC added a loop counter to the ALU that keeps track of repeat instructions for rotate and shift so they don't have to be constantly inputted from the microcode ROM.

NEC also added an Effective Address Generator (EAG) to the V30. This performs high-speed processing of memory locations for memory accessing. Calculating by the microcode method normally requires 5 to 12 clock cycles. The EAG generates effective addresses using hardware and needs only two clock cycles. A program counter and a prefetch pointer offer more efficient use of the branch, call, return, and break operations by keeping track of current and future program addresses.

The entire procedure requires nearly twice as many

transistors as the original microprocessor. This approach is necessary, however, if the new architecture is to be externally compatible with existing designs.

### Improved instruction set

Complete compatibility between the 8086 and V30 is, of course, essential to the V30's success. And the same qualifications apply to the software. NEC duplicates the entire 8086 instruction set. To take full advantage of the hardware improvements, they found it necessary to enhance 16 of the original instructions and add 14 brand new ones.

Enhancements are made to the SHIFT (SH) and ROTATE (RO) instructions, as well as the MULTIPLY (MUL) command, to take advantage of the new temporary shift registers attached to the ALU. PUSH and POP are enhanced to deal with 8 general registers at once and there are changes in the way the chip deals with block memory and block I/O instructions. A list of enhancements is shown in Fig. 3.

In addition to the 8086 instructions and the enhanced instructions, the V30 also contains the following unique instructions.

Two instructions are used for variable length bit field operations. These are effective for dealing with packed arrays found in screen graphics and higher-level languages, like PASCAL. Another group of instructions manages packed BCD (binary coded decimal) data as strings or byte-formatted operands. The third group deals with the manipulation of specific data bits within data registers or memory locations. A breakdown of the new instruction set is outlined in Fig. 4.

### Starting a family

NEC is offering two enhanced versions of the 8086 microprocessor. The first, an 8-bit external bus microprocessor that NEC affectionately calls the V20, is the electrical and logical equivalent of the 8088. The

ENHANCED INSTRUCTIONS	
Instruction	Function
PUSH imm	Pushes immediate data onto stack
PUSH R	Pushes 8 general registers onto stack
POP R	Pops 8 general registers from stack
MUL imm	Executes 16-bit multiply of register or memory contents by immediate data
SHL imm8	Shifts/rotates register or memory by SHR imm8 immediate value
SHRA imm8	
ROL imm8	
ROR imm8	
ROLC imm8	
RORC imm8	
CHKIND	Checks array index against set boundaries
INM	Moves a string from an I/O port to memory
OUTM	Moves a string from memory to an I/O port
PREPARE	Allocates an area for a stack frame and copies previous frame pointers
DISPOSE	Frees the current stack frame on a procedure exit

Fig. 3—THE ABOVE INSTRUCTIONS have been enhanced from the 8086/8088 instruction set as indicated.

### NEW INSTRUCTIONS

Instruction	Function
INS	Insert bit field
EXT	Extract bit field
ADD4S	Adds packed decimal strings
SUB4S	Subtract packed decimal string
CMP4S	Compares two packed decimal strings
ROL4	Rotates one BCD digit left through AL
ROR4	Rotates one BCD digit right through AL
TEST1	Tests a specific bit and sets Z flag
NOT1	Inverts a specific bit
CLR1	Clears a specific bit
SET1	Sets a specific bit
REPC	Repeats next instruction until CY is clear
REPNC	Repeats next instruction until CY is set
FPO2	Additional floating point processor call

Fig. 4—THE INSTRUCTIONS ABOVE are new to the 8086/8088 instruction set. Altogether, there are 14 new instructions divided into three categories: variable length bit field operations, packed BCD operations, and bit manipulation instructions.

second, the V30, duplicates the 8086 with its 16-bit external bus structure. Both use 16-bit internal buses and both are hardware and software replacements for their counterparts.

Things are moving fast, and the computer of the future will be something to behold. It is reassuring to know, though, that companies like NEC are doing their best to keep existing technology current.

If you ever wanted to feel the acceleration of a turbocharged machine, now is your chance. The NEC V20 offers the perfect opportunity for IBM PC and PC compatible owners to upgrade for a fraction the cost of a turbo board. To begin, remove your old 8088 microprocessor chip and replace it with a V20 to gain both speed and expanded programming capabilities. The chips are pin-for-pin compatible and no software or hardware adjustments are required.

To install the new chip you remove the five 1/4-inch screws securing the cover to the back panel and sliding the cover forward. Locate the 8088 microprocessor chip. It is at the rear, ahead of the cassette connector.

Make sure you are free of static electricity before proceeding. A good precaution is to touch your hands to the metal chassis before working. Gently remove the 8088 from its socket using a chip puller.

Insert the new chip by aligning its legs with the socket pins (locating notch facing the rear apron) and firmly push into place. Replace the cover.

This \$30 chip won't transform your PC into an AT. But it will improve overall performance by 10 to 20 percent. This is just the tip of the iceberg. The real impact of the upgrade will be realized when software houses start incorporating the new instruction set in their products. Meanwhile, enjoy the benefits of tomorrow's technology.

*NOTE: If you are having trouble locating a V20 processor, contact Westpro Data Sources at 21704 Golden Triangle Road, Saugus, CA 91350. They will ship you a V20 for \$30 ppd. Other V-series chips are also available; contact Westpro for price and availability.* ◀▶

# OPTICAL DISKS

Soon you may be "playing" Compact Disks on your computer!

Marc Stern

■ Do you remember when laser disk players were the rage? It was a short time ago they were supposed to sweep the video field. It never happened and they faded from that picture temporarily. Well, they're back, but their name and use has changed radically.

Instead of creating TV images, they are creating sounds heard in compact disk audio players and are beginning to appear as read-only storage devices in microcomputers. And instead of being called laser video disks, they're now called compact audio disks, or, in the computer world, optical storage disks, compact disks or compact-disk-read-only memory (CD-ROM).

When you think about it, using a laser-created optical disk for storage makes sense.

Unlike magnetic media where data are recorded via frequency modulation, optical disks are created as a laser-through burn in tiny sections of substrate within the disk. The burn or lack of a burn determines if a digital 1 or 0 has been recorded. Optical disks are instantly digital.

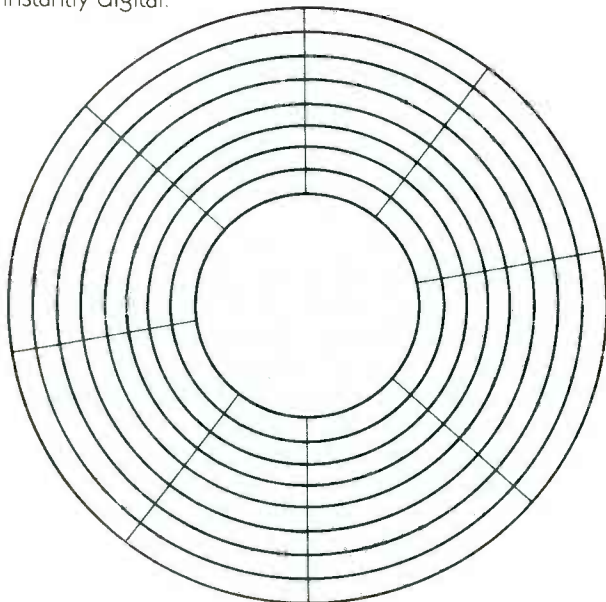

**FIG 1—ORGANIZED IN CONCENTRIC RINGS**, the outer sectors of a standard disk are recorded using constant angular velocity where the outer sectors are physically larger than the inner sectors of a disk. Each track is made up of a specific number of sectors and the size differential is due to the fact that the speed of the outer rim of the disk seems greater than that of the inner areas. To keep things equal, the size of the outer sectors increases because of the increased apparent speed.

## Advantages

The most obvious advantage of an optical disk is its permanence. Like a compact audio disk, data are recorded and encased within a compact disk's plastic shell and can't be changed or erased. On a floppy or hard disk, coated with magnetic media, stray magnetic fields, heat, cold, dust or smoke may cause data to be corrupted. Floppy or hard disks can at best be thought of as temporary long-term storage, while optical disks can be thought of as long-term, permanent storage.

---

***The most-obvious advantage of an optical disk is its permanence. Optical disks are impervious to damage. Since the optical disk's recording surface is in a plastic layer or shell, it can be manhandled.***

---

Optical disks are impervious to damage. If you've worked with microcomputers you know the caveats of disk handling, watching out for fingerprints; dust; cigarette smoke, and the like. Since the optical disk's recording surface is in a plastic layer or shell, it can be manhandled. Fingerprints won't harm the data surface and neither will dust, cigarette smoke or magnetic fields.

From a storage standpoint, the key to an optical disk is data density. Rather than just storing 10 megabytes or 20 megabytes, as is now commonly done on personal computer hard disks, optical disks are capable of storing from 200 megabytes to 1 gigabyte of data. As an analogy, think of storing the entire "Encyclopaedia Britannica" in your microcomputer. It will take several hard disks or many boxes of floppies. In contrast, you can easily store it on one optical disk and still have some room left over.

An optical disk's biggest storage disadvantage is its one-write nature. After it has been filled once, nothing can be added. Research has been conducted for the last several years in an effort to make optical disks read-and-write devices, but it still hasn't paid off to any cost-effective degree.



In a way, optical disk technology is perhaps the ultimate solution to computer compatibility. In the floppy and hard disk world, PC/MS-DOS has offered a measure of compatibility among differing systems. However, since there is only one major standard for optical disks, developed by Phillips and Sony, optical disks for one microcomputer system should work on another.

The impetus to this standard, by the way, was the digital audio standard developed for compact disk players by the two electronics giants.

## Differences

Up to now, we've explored the chief differences between traditional magnetic disk technology and optical disk technology. Now let's look at the more technical issues that explain other differences.

Foremost among the technical differences is the format of the surface of the disk. Like a traditional disk, the optical disk has tracks and sectors, but, unlike the traditional disk, it uses a different physical format.

Traditional disk technology defines its format using constant angular velocity. To explain, take a close look at Fig. 1 and you'll see that the data sectors toward the center of the disk are smaller than those at the rim where the circumference is greater and the disk's relative linear speed also seems greater, with respect to the center. Because of the seeming speed difference the physical size of the data sectors must be larger to keep sectors equal. Thus, angular velocity across the section of the disk is kept equal by the changing size factor of each sector.

An optical disk differs because the read head and the disk surface retain the same relative speed at all times. To do this, the disk's speed is changed as the read head moves across. This results in a spiral arrangement of data sectors, all having the same linear length because they're recorded at the same apparent speed. If you look closely at Fig. 2, you'll see that since data tracks spiral toward the rim, there are fewer data

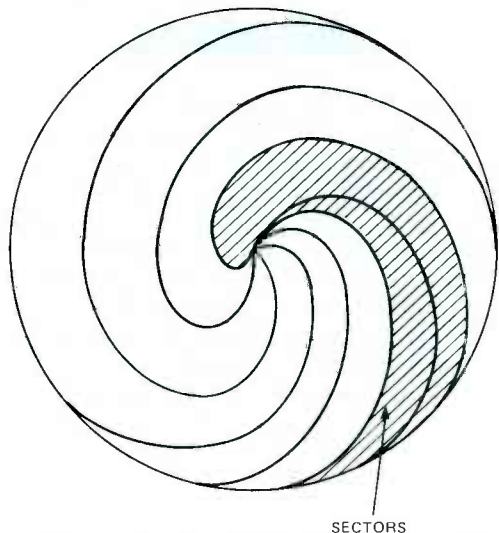

**FIG 2—WITH CONSTANT LINEAR VELOCITY, the read head and disk speed remain the same across the disk. The result is a series of tracks whose sectors are physically the same length but which appear spiral in shape.**

sectors on the center than at the edge. The ratio can vary by more than 2 to 1, or 9 sectors at the center and 20 at the rim, per track.

This complicates things on an optical disk because there are no fixed reference points. With constant angular velocity recording each track contains a fixed number of sectors. It is easy to find the location of a track and sector, if your system knows the starting track and sector address of a file. The read-write head moves ahead N locations to find it, once it knows the original address.

Things are more complicated on an optical disk. With a surface of spiral tracks, try to find a specific location easily. Because there is no fixed relationship between the an optical disk's track and the number of sectors on the track, the microcomputer has to go through a more complicated routine finding a location.

Further complicating this is speeding up or slowing the disk's rotation so the speed of the head and disk remain constant. When these two factors are taken into consideration, accessing information is slower than other types of storage media.

It's not uncommon for an average seek to take 500 ms, while the worst case time approaches 1 second. This contrasts with average seek times in the 100 ms range for an average 10 megabyte hard disk and worst case times in the 200 ms range. Performance differences can also be seen in the fact that an optical disk's average latency is 100 ms, while it is only 8.3 ms for the fixed disk.

---

***Rather than storing 10 to 20 megabytes as is done on PC hard disks, optical disks can store 200 megabytes to one gigabyte. More than enough to hold the entire Encyclopedia Britannica!***

---

Optical disks have good transfer rates, about 150Kbytes per second, while most hard disks are in the 96Kbyte range. Data transfer can be speedy on an optical disk, once the location is found. Average track-to-track seek times run in the 1 ms range for the optical disk, while they average 3 ms for the standard 10-megabyte hard disk. The reason the optical disk is quicker is the mirrored head has a sequential access range of 40 nearby tracks without a move, while the fixed disk's head must move from track to track. Further, data on an optical disk remain sequential, while they become random on a hard disk that has been accessed a great deal.

In favor of optical disks is storage. The average optical disk can store between 200 and 500 megabytes of data, while high-performance disks approach 1 gigabyte. This contrasts markedly with the average hard disk that stores only 10 megabytes of data.

# R-E Computer Admart

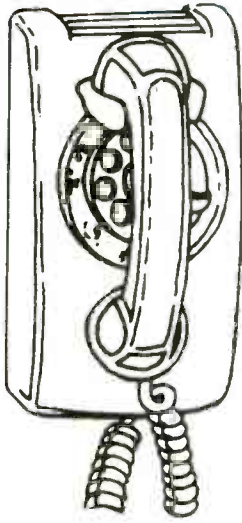

## CALL NOW AND RESERVE YOUR SPACE

- 6 x rate \$800.00 per each insertion.
- Reaches 229,044 readers.
- Fast reader service cycle
- Short lead time for the placement of ads.

Call 516-293-3000 to reserve space. Ask for Arline Fishman. Limited number of pages available. Mail materials to: Computer Admart, RADIO-ELECTRONICS, 500-B Bi-County Blvd., Farmingdale, NY 11735.

Rates: Ads are 2 1/4" x 2 7/8" One insertion \$825. Six insertions \$800 each. Twelve insertions \$775. each. Closing date same as regular rate card. Send order with remittance to Computer Admart, Radio Electronics Magazine, 500-B Bi-County Blvd., Farmingdale, NY 11735. Direct telephone inquiries to Arline Fishman, area code 516-293-3000. Only 100% Computer ads are accepted for this Admart.

### ICs PROMPT DELIVERY!!!

SAME DAY SHIPPING (USUALLY)

QUANTITIES AND PRICES SHOWN FOR JUNE 30, 1986

OUTSIDE OKLAHOMA: NO SALES TAX

DYNAMIC RAM			
1M	1000Kx1	100 ns	\$70.00
256K	64Kx4	150 ns	4.00
256K	256Kx1	100 ns	5.50
256K	256Kx1	120 ns	3.40
256K	256Kx1	150 ns	2.85
128K	128Kx1	150 ns	4.25
64K	64Kx1	150 ns	1.35
EPROM			
27512	64Kx8	250 ns	\$23.00
27C256	32Kx8	250 ns	6.95
27256	32Kx8	250 ns	5.20
27128	16Kx8	250 ns	3.65
27C64	8Kx8	200 ns	4.75
2764	8Kx8	250 ns	3.40
STATIC RAM			
43256L-12	32Kx8	120 ns	\$35.00
6264LP-15	8Kx8	150 ns	2.99

OPEN 6 1/2 DAYS: MasterCard/VISA or UPS CASH COD

SUNDAY & HOLIDAYS: SHIPMENT OR DELIVERY VIA U.S. EXPRESS MAIL  
SAT DELIVERY INCLUDED ON FED-EX ORDERS  
RECEIVED BY: Th. 9:00 AM - 5:00 PM, Fr. 9:00 AM - 12:00 PM  
Factory New, Prime Parts  
MICROPROCESSOR UNLIMITED, INC.  
24 000 S. Peoria Ave. BE GGS OK 73421  
(918) 267-4961, 62, 63, 64

CIRCLE 193 ON FREE INFORMATION CARD

### CompDes™ Computer-Aided Circuit Design For IBM-PC and Compatibles

A Menu driven electronic design software tool for students, technicians, engineers. Program will design passive & active filters, attenuators, power supplies, amplifiers, etc. Has calculating programs for resistance, reactance, dB's, VSWR, and more. MS/DOS 2.0-up, 128K memory req. Includes design manual. \$49.95 (Ohio add 2.75 tax) M/C or Visa (614) 491-0832.

**EISOFT SOFTWARE**  
P.O. Box 072134  
Columbus, Ohio 43207

CIRCLE 186 ON FREE INFORMATION CARD

### AN INTRODUCTION TO Z-80 MACHINE CODE

An Introduction to Z80 Machine Code



BP152—Machine code programming is direct programming of the microprocessor without using a built-in high-level computer language such as BASIC. You can increase running speeds dramatically by using machine code. Learn how to write your own machine code programs. Some simple demo programs are included. Get your copy by sending \$5.95 plus \$1.00 shipping in the U.S. to Electronic Technology Today Inc., P.O. Box 240, Massapequa Park, NY 11762-0240.

### MICRO INTERFACING CIRCUITS — BOOK 2

Micro Interfacing Circuits Book 2



BP131—This book is about real-world interfacing including topics such as sound and speech generators, temperature and optical sensors, motor controllers and more. Includes circuit descriptions and background info to aid in using or adapting the circuits to your applications. To order your copy send \$5.75 plus \$1.00 shipping in the U.S. to Electronic Technology Today Inc., P.O. Box 240, Massapequa Park, NY 11762-0240.

### Unique address scheme

An optical disk has a unique address scheme. Since it is based on digital audio recording technology, we must think in those terms. So, we must first consider the optical disk as "playing," rather than accessing or running.

Each disk plays (records) for 60 minutes and each minute is divided into 60 seconds. This is the basis of the optical disk addressing. There is one more factor, the sector number.

Instead of addressing a piece of data as X track-Y sector as on a traditional hard or floppy disk, the optical disk addresses it as X-minutes-Y-seconds-Z-sectors. A third dimension has been added to this relationship. It means that current software and directory addressing systems have to be rewritten to work with the new address mode.

This type of addressing is important given the

changing nature of the data tracks and the number of sectors. In this manner, the three coordinates locate a given piece of data with pinpoint accuracy.

The read-write head consists of mirrors; a laser data decoder, and read circuitry. It is more complex than a typical read-write head on a hard or floppy disk.

As the head records each block of data, a correction code is generated. That error correction code mirrors the information stored in a particular sector so if something is corrupted during the recording session, there is backup data encoded so the information will be read correctly when called for. This cuts the amount of space available for storage, but ensures that data will be read correctly.

Despite their performance problems, optical disks represent great potential for the microcomputer user and industry. Now you know why the optical disk is the hot ticket in town this year. ◀▶

- 400 MHz to 900 MHz
- 950 MHz to 1450 MHz
- Any 500-MHz band between 300 and 1500 MHz
- 3,700 MHz to 4,200 MHz.

That combination of bands makes it possible for the installer to detect and display either a full 500-MHz-wide satellite downlink, or, with the assistance of the unit's controls, any span as narrow as 2 MHz within any of the covered bands.

The 3,700- to 4,200-MHz band covers the satellite downlink frequencies. A built-in low-noise amplifier can be coupled to the TVRO antenna of the system to be installed or to a separate horn antenna. In either case, the analyzer can be used to display both the desired signal and any interfering signals directly.

The other five bands cover all of the commonly found TVRO IF's (Intermediate Frequencies). That allows the system installer to verify the performance of downconverter and LNB (Low-Noise Block Downconverter) units, to check cable losses and fittings, to measure distribution system parameters, and even to check for the correct operation of a cable-TV system.

### What made it possible

Low-cost microwave test equipment has been feasible for several years. However, the specialized knowledge that designers of TVRO receivers had acquired was missing. In particular, flat mixers and flat sweep oscillators had to be developed using the same low-cost approach as TVRO receivers. Some exciting developments in YIG (Yttrium-Iron-Garnet) oscillator designs also helped pave the way for low-cost spectrum analyzers and other high-frequency test equipment.

For example, other generally-available test gear can provide: direct frequency readout of carriers to 4,200 MHz (accurate to 1 MHz) for under \$1,000; accurate readout at 4,200 MHz of signal levels to within  $\pm 2$  dB for under \$500; and direction-finding interference-locating systems accurate to within 5 degrees for under \$600. You can even purchase microwave signal generators capable of generating

significant amounts of power modulated by color bars and an audio tone, or by your own video source (such as a tape deck or a video camera), for under \$1,000. None of that equipment was practical, and a great deal of it was simply impossible, as little as two years ago.

The new microwave gear can be put to use in other bands as well. For example, Ku-band equipment (which operates in the 11- and 12-GHz bands) may be tested and aligned by simply connecting an LNB ahead of a 4,200-MHz instru-

ment. That's a cost-effective solution to a potentially sticky problem, because an LNB can be obtained for under \$200.

Other fields may also benefit from advances made in microwave test instrumentation. Virtually any electrical quantity can now be measured with a high degree of accuracy at frequencies as high as 4,200 MHz, and even higher.

So if you service or install high-frequency equipment of any sort, you should be grateful to the TVRO industry—advances made there will benefit all of us. **R-E**

# SCRAMBLE-FAX SCRAMBLE-FAX

from Bob Cooper

**IF satellite scrambling is important to you, here is a single source of timely, confidential information of great value; SCRAMBLE-FAX.** Bob Cooper is routinely gathering all of the important scrambling information (who, what, when, where and how) and compiling it in printed form in an important newsletter called *SCRAMBLE-FAX tm*. Sources for pirate decoders, reports on attempts to 'beat the system', full lists of who is scrambling, how and when. Each issue of **SCRAMBLE-FAX** is timely and new; but, each issue is a detailed encyclopedia of scrambling information and totally complete.

**REPORTS** on M/A-Com efforts to shut down pirate units, exporting of bootleg descramblers outside of the USA, complete listings of all (37+) channels now scrambling and those planning to scramble. The activities of DESug, the DES Users Group, and their progress on 'breaking' the Videocipher 'code', modifying receivers to accept Videocipher and much-much more.



**EACH** issue of **SCRAMBLE-FAX** is sent to you via AIR-mail the very day your order is entered. Simply call 305/771-0505 to order your copy (have VISA or Mastercharge card handy) or write for your copy enclosing payment for \$10 (US funds) to the address shown below. **PLUS** — each issue is 'supported' by a **SCRAMBLE-FAX 'Hotline'** telephone updating service.

WESTAR Communications/Westcom, the Toronto area alleged manufacturer of 'pirate decoders' for HBO/Showtime and other Videocipher type scrambled services reportedly has been sold to a new group of investors; all Canadian. The firm has been offering their pirate-type decoder unit for \$500 (US) for several weeks claiming it decodes all Videocipher scrambled video plus audio signals. Attempts to locate the firm other than through their 800 telephone number (1-800/265-5675) typically meet with failure and the firm is quick to explain that it would be inappropriate for them to identify their actual street address location (SCRAMBLE-FAX suggests you try 504 Iroquois Shore, Oakville, Ontario; and 416/842-2877 as their non-800 telco).

**DIAL 305/771-0575** anytime for a complete update on the status of scrambling. 'Hotline' recorded reports are provided by Bob Cooper as an 'instant update' to **SCRAMBLE-FAX** and carry fast-breaking news items of interest to the scrambling scene. But have your notebook and pen handy; each 'Hotline' report contains many telephone numbers and addresses you will want to retain!

## SCRAMBLE-FAX by Bob Cooper

305/771-0505 or for free 'Hotline' service, 305/771-0575. To order by mail, send check/money order or enclose VISA/Mastercharge number and expiration date: CSD Magazine, P.O. Box 100858, Ft. Lauderdale, Fl. 33310

# ROBOTICS



MARK J. ROBILLARD,  
ROBOTICS EDITOR

## Position sensing

YOU DON'T HAVE TO WORK WITH A robot arm for long to realize that position information is highly important. There are numerous ways of obtaining that sort of information; let's examine several.

### Digital position sensing

Most digital approaches to position sensing involve optical devices. Recently in this column we discussed tactile sensing using IR emitters and detectors. Some of the same approaches can be used for position sensing.

For example, a device called an optical shaft encoder or an optical interrupter encodes the position of a shaft by means of opto-electronics. An infrared (IR) detector/emitter pair couples to the shaft of a motor or the pivot of a robot arm and provides a series of digital pulses. The encoder requires only a source of five-volt power. How does it work?

A disk like the one shown in Fig. 1 is used to interrupt a beam of infrared light passing from an LED

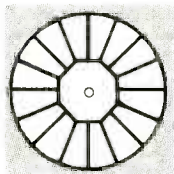

FIG. 1

to a photo-transistor. Overall the disk is transparent, but it has dark stripes that block the IR periodically as it spins. The LED and the transistor are integrated in a single package, as shown in Fig. 2. The encoder disk is attached to the end of a rotating shaft, and

then it passes through the slot in the optical interrupter. As the shaft turns, the disk rotates, so the dark areas of the disk periodically prevent the LED light from reaching the photo-transistor. The output of the detector is a series of pulses that may be squared up and fed to digital control circuitry.

The disk is manufactured so that the distance between each radial stripe is equal. So the number of pulses that are output indicate how far the shaft has turned. Industrial optical encoders may have several hundred, or a thousand or more divisions.

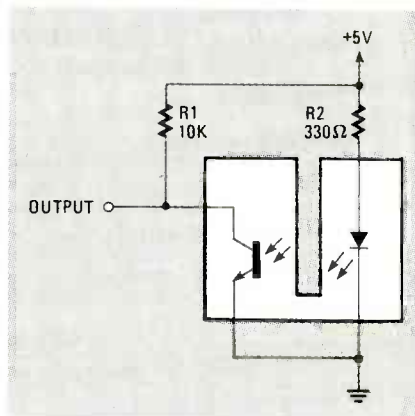

FIG. 2

Commercial encoder disks are usually expensive because they are manufactured under tight mechanical tolerances. In addition, they offer a minimum of 256 slits. For purposes of experimentation, sixteen slits are sufficient because hobbyist-grade motors cannot be positioned very accurately.

You could photocopy the disk in Fig. 1 on a piece of acrylic to provide position information for a Milbro Bradley *Robotix* arm. The basic idea is shown in Fig. 3.

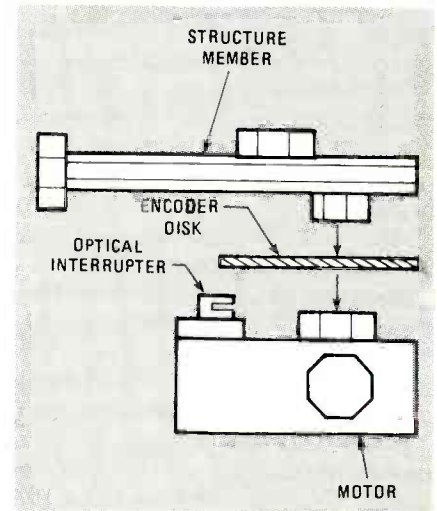

FIG. 3

The optical interrupter is readily available, but if you have trouble locating one, or if you would like to purchase some encoder disks, MJR Digital (Mason Road, Milford, NH 03055) has an experimental kit consisting of nine transmissive encoder disks, nine reflective encoder disks, five H22A1 optical interrupters, and an application note available for \$19.95. We'll discuss use of the reflective encoder disks below.

Because two connections go to ground, only three wires must be brought to the encoder. In addition, several encoders may share the ground and five volt lines.

To use the encoder, the computer that controls the motor must monitor the output of the encoder. To begin a motion sequence, the arm must be "homed." In other words, the joint (or joints) in question must be brought to a limit—all the way up, down, left, right, etc.

The computer must then read the status of the encoder. If the

output is low, then any subsequent high indicates movement. Conversely, if the initial reading is low, then subsequent highs indicate an absence of movement. It's important to know whether you're starting with a high or a low; otherwise you may not be able to return the arm to the home position accurately.

To move the arm to a specified position, load a counter with the number of slits that must be counted. Then, after homing the arm, turn on its motor and monitor the encoder's output for a pulse. When a high or a low (as previously described) is detected, decrement the internal counter. Repeat that operation until the counter has a value of zero. At that point the arm should be in the desired position.

You could perform the counting in hardware (without a computer) if you like. Doing that is simply a matter of using a counter IC and a logic gate to shut the motor off when the counter reaches zero.

### Reflectance decoder

In some situations, a reflectance-type encoder disk is more practical. Rather than a clear disk with dark stripes, a reflectance disk is basically reflective with dark stripes. It is used as shown in Fig. 4.

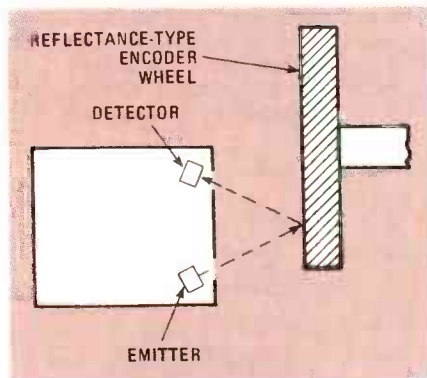

FIG. 4

A beam of infrared light is emitted from an IR emitter at an angle. An IR detector is mounted at a complementary angle. Light will be reflected from the reflective areas of the disk, and not from the striped areas. As the joint moves, the wheel turns, so the output of the detector is a series of highs and lows, like those produced by the

transmissive disk. That data can be used to position the arm as previously described.

### Analog sensing

Of course, there are other ways to sense the position of an arm. An analog approach might use a variable resistor, an A/D converter, and a little software. The shaft of a potentiometer is connected to the pivot point of a robot's arm, so the potentiometer's resistance should provide an accurate indication of

the arm's position. The voltage across that resistor would be read by the A/D converter, and the control computer could then use that information to make an intelligent decision about what step should be done next.

The arm must start from a known position, so, on power up, the arm should be homed. That is best accomplished by rotating each pivot until a microswitch (used as a limit indicator) is activated. At that point motion must halt. Then the control

### Digital Multimeter



The BM 317 can easily read DC voltage. Range 200mV, 2V, 20,200V, 1000V, DC/AC current. Range 200uA, 2mA, 200mA, 2000mA, 10A. AC Voltage Range, 200mV, 2V 20V, 200V, 750V, Resistance Range: Hi-Low Resistance/Diode Check Display, 3 1/2 Digit LCD, 9V Battery or AC Adapter, A 2000 Hours Battery Life, Spare Fuse

Reg. Price \$89.00  
Special Sale Price  
**\$39.00** ea.



### Adjustable Temperature Controlled LED Type Soldering Station

Reg Price \$80  
Special Sale **\$55.00** ea.

FEATURES: TEMPERATURE DIRECT READING. CONSTANT TEMPERATURE CONTROL. TEMPERATURE RANGE (300-1000°F) HEATED POWER: 48W FOR SOLDERING IRON 20W FOR SOLDERING PENCIL

### TRANSISTORS

A-41.....SANYO 1308K.....1-49	<b>1.79</b>	50-99	<b>1.59</b>	100-up	<b>1.45</b>
A-15.....TOSHIBA 1172B.....1-25	<b>2.65</b>	26-49	<b>2.25</b>	50-up	<b>2.00</b>

### TRIPLERS:

T-184 equivalent to ECG-523	1-9	10 up
T-53 equivalent to ECG 526	<b>\$9.95</b>	<b>\$8.99</b>
T-45 equivalent to ECG 500A		

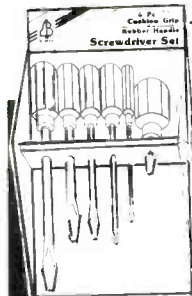

### ALL SAFETY CAPACITORS

GE, Magnavox, Sony, Sears **10 FOR \$35.00** CALL FOR NUMBERS

### 6 Piece Cushion Grip Screwdriver Set

MOST POPULAR SCREWDRIVER 5/16x6, 1/4x4, 1/8x3, 3/16x4, 1/4x11, 1/2, #2 PHILLIPS HEAD.

Super **\$1.00** PA-109  
Special **1.00** EA.  
Reg. Price \$4.50

### COAXIAL CABLE

Copper Braid Shield

RG 59u .....1000' .....Reg. \$82.00 **SALE \$44.00**

RG 6u ....500' ..Reg. \$55.10 **SALE \$35.95**

Add \$5.00 per roll shipping

call for  
our free  
104 Page  
CATALOG

ORDER BY PHONE:

**800-645-4720**

or (516) 379-2202

**ESI**

Electronic Parts & Accessories

3820 14th Avenue, Brooklyn, NY 11218

a division of **ALPHA-KENCO INC.**  
SYSTEMS & ELECTRONICS



CIRCLE 204 ON FREE INFORMATION CARD

# Radio-Electronics mini-ADS

computer should check the output of the A/D device. The voltage read there represents a reference point in relation to which other positions are known.

Some A/D converters require supply voltages of  $\pm 12$  or even  $\pm 15$  volts. However, there are several 5-volt A/D IC's on the market. For example, National Semiconductor's A/D0816 can digitize 16 channels of analog information. Each channel has eight bits, so any input between 0 and 5 volts will be converted to one of 256 digital values in steps of about 20 mV. Other A/D IC's provide 12 bits, for a total of 4096 discrete values.

There are several drawbacks to the analog approach. The first is that the potentiometer must be coupled physically to the arm's pivot, and that may be difficult. Also, the mechanical drag of the potentiometer may adversely affect the operation of the arm. And for the beginner, the most serious drawback may be creating the software required to operate the A/D converter.

Speed may also be a problem. Many A/D converters operate much slower than the digital systems controlling them. Often a computer must wait until the A/D converter is ready.

A typical computer-to-A/D dialog might go like this: The computer asks for the current reading, then the A/D works on the request. Some hundreds of microseconds later, the A/D signals the computer that the current reading is ready. Then the computer reads the value. If necessary, the process then repeats.

The speed problem can be alleviated by using a faster A/D converter. However, they're harder to find and more expensive than run-of-the-mill hobbyist-grade devices. And for experimental purposes, a slow A/D converter should prove to be quite sufficient.

As you can see, there are a number of ways of gaining position information about a robot arm. Some of those methods are more useful than others in different circumstances, but the digital approach is generally the simplest to implement as well as the most accurate.

R-E



**THE MODEL WTT-20 IS ONLY THE SIZE OF A DIME**, yet transmits both sides of a telephone conversation to any FM radio with crystal clarity. Telephone line powered - never needs a battery! Up to 1/4 mile range. Adjustable from 70-130 MHz. Complete kit **\$29.95 + \$1.50 S+H**. Free Shipping on 2 or more! COD add \$4. Call or send VISA, MC, MO. **DECO INDUSTRIES, Box 607, Bedford Hills, NY 10507. (914) 232-3878.**  
CIRCLE 127 ON FREE INFORMATION CARD



**APPLIANCE REPAIR HANDBOOKS—13** volumes by service experts; easy-to-understand diagrams, illustrations. For major appliances (air conditioners, refrigerators, washers, dryers, microwaves, etc.), elec. housewares, personal-care appliances. Basics of solid state, setting up shop, test instruments. **\$2.65 to \$5.90 each**. Free brochure. **APPLIANCE SERVICE, PO Box 789, Lombard, IL 60148. 1-(312) 932-9550.**  
CIRCLE 84 ON FREE INFORMATION CARD



**TV STEREO/SAP RECEIVER: Only \$89.00** to turn your existing TV set into a true stereo television. Simply hook it into a mono-aural TV & tune it to the same station. Also available 4.5 mhz SIF with picking probe & CATV use only. 4 weeks delivery. **INTEK ELECTRONICS, P.O. Box 76417, Los Angeles, CA 90076, (213) 739-1664/388-9993**  
CIRCLE 195 ON FREE INFORMATION CARD

## CALL NOW AND RESERVE YOUR SPACE

- 6 x rate \$745.00 per each insertion.
- Reaches 229,044 readers.
- Fast reader service cycle.
- Short lead time for the placement of ads.
- We typeset and layout the ad at no additional charge.

Call **516-293-3000** to reserve space. Ask for Arline Fishman. Limited number of pages available. Mail materials to: mini-ADS, RADIO-ELECTRONICS, 500-B Bi-County Blvd., Farmingdale, NY 11735.

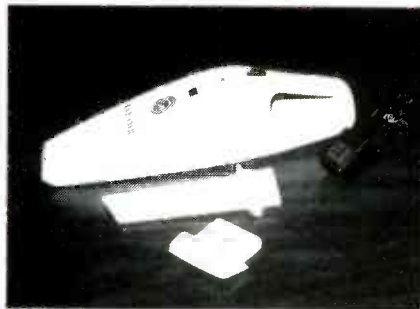

**GN RECHARGEABLE PORTABLE CLEANER.** (New Model) both items charge from AC house & DC cigarette socket also cordless use. Standard Model - (\$19.50), Plus Model - (\$22.50), 2 year warranty. CA residents add (6.5%) tax, shipping \$2.00, Money Orders & Checks accepted send: **GENTLE WAYEER ELECTRIC INC. 324 S. Palm Ave. #D, Alhambra CA 91803 TELE: 818-289-2050: TELEX 3717727 WAYEER US.**  
CIRCLE 200 ON FREE INFORMATION CARD

### 103 PROJECTS FOR ELECTRONICS EXPERIMENTERS



**103 PROJECTS FOR ELECTRONICS EXPERIMENTERS.** Soft cover; 308 pages of practical, proven plans for the electronics hobbyist...circuits, converters, amplifiers, synthesizers, optoelectronics, power supplies and more. Written and designed by Forrest M. Mims, III. 1249I \$11.50 plus \$1 postage in USA. **ELECTRONIC TECHNOLOGY TO-DAY INC., PO Box 240, Massapequa Park, NY 11762-0240.**

# Radio-Electronics mini-ADS



**60 dB SIGNAL ELIMINATOR** for removal of troublesome or unwanted TV/FM signals. Can be tuned precisely to ANY signal within these ranges: • Model 26—Ch's. 2-6 [54-88 Mhz.] • Model 1422—Ch's. 14(A)—22(1) [120-174 Mhz.] • Modified Model 26—FM Stations 88-108. Strength is adjustable from 15-60 dB. For one unit send **\$30.** (Refundable). Quantity discounts to 60%. **STAR CIRCUITS, P.O. Box 8332, Pembroke Pines, Fla. 33084**  
CIRCLE 198 ON FREE INFORMATION CARD



**SUBSCRIPTION TV MANUAL.** This information packed book details the methods used by subscription TV companies to scramble and descramble video signals. Covers the Sinewave, Gated Pulse, SSAVI system, and the methods used by most cable companies. Includes circuit schematics, theory, and trouble shooting hints. **Only \$12.95** plus \$2.00 first class P&H. **ELEPHANT ELECTRONICS, INC., Box 41865-R, Phoenix, AZ 85080**  
CIRCLE 120 ON FREE INFORMATION CARD



**SEE IN TOTAL DARKNESS - BUILD THIS AMAZING IR VIEWER.** Applications include: night surveillance, IR photography, laser tracking, fibre optic observations, hi-temp thermal viewing, IR alarms. IR communications & controls, IR astronomy & microscopy, document examination, painting & stamp authentication etc. Kit **\$189** delivered. (Dealers wanted). Catalog \$1. 514-739-9328. **CROSLY ELECTRONICS, Box 840, Champlain, N.Y. 12919**  
CIRCLE 192 ON FREE INFORMATION CARD



**FREE CATALOG OF HARD-TO-FIND TOOLS** is packed with more than 2000 quality items. Your single source for precision tools used by electronic technicians, engineers, instrument mechanics, schools, laboratories and government agencies. Also contains Jensen's line of more than 40 tool kits. Send for your free copy today! **JENSEN TOOLS INC., 7815 46th St., Phoenix, AZ 85044. (602) 968-6231.**  
CIRCLE 115 ON FREE INFORMATION CARD



**GATED PULSE DESCRAMBLERS, only \$169.** ZENITH SSAVI **\$169** each. Reconditioned original equipment for UHF chs. 27,48,51,60, etc. Quantity discounts. Satellite equipment. Surplus TV equipment: N-12, SB-2, SB-3, Hamlin 1200, auto on/off, converters, amplifiers, etc. Catalog \$1. SSAVI modification/troubleshooting handbook \$6.50 ppd. Satisfaction guaranteed. **AIS SATELLITE, INC., P.O. BOX 1226-R, Dublin, PA, 18917. 215-249-9411.**  
CIRCLE 81 ON FREE INFORMATION CARD



**SIMPLY SNAP THE WAT-50 MINIATURE FM TRANSMITTER** on top of a 9v battery and hear every sound in an entire house up to 1 mile away! Adjustable from 70-130 MHz. Use with any FM radio. Complete kit **\$29.95 + \$1.50 S + H.** Free shipping on 2 or more! COD add \$4. Call or send VISA, MC, MO. **DECO INDUSTRIES, Box 607, Bedford Hills, NY 10507. (914) 232-3878.**  
CIRCLE 127 ON FREE INFORMATION CARD

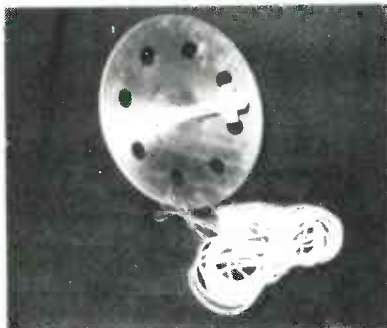

**MICROWAVE ANTENNAS \$69.95.** Now including shipping and Lifetime warranty. We Repair all types of Downconverters. Cable Converters and equipment available! Jerrold 400 wireless Converter **\$72.95** plus shipping. Coax cable, T.V. parts, accessories, connectors, T.V. amplifiers. Write for free catalog or call for prices. **BLUE STAR IND., Dept. 105-RE9-86, 4712 Ave. N, Brooklyn, N.Y. 11234 (718) 338-8318 Ext. 105.**  
CIRCLE 85 ON FREE INFORMATION CARD



**2.5" CHARACTER HEIGHT ALPHA-NUMERIC LCD MODULES,** built-in driver, memory, serial data input/output, cascadable into row configurations **\$19.95.** Programmable LCD moving message sign **\$399.00.** Standard and custom design LCD's available with fast lead time for prototype and production runs. Our engineering facility provides technical support to interface LCD's into your products. Cheque or money order. **ALL-CRYSTAL DISPLAYS, 237 Lauzon Road, Windsor, Ontario, Canada, N8S 3L7. Tel: (519) 948-7225, Telex: 064-77624 WND.**  
CIRCLE 187 ON FREE INFORMATION CARD



**THERMOPROBE—QUICKLY IDENTIFIES DEAD PC BOARD COMPONENTS.** Locates dead resistors, transistors, IC's, diodes, and transformers without direct contact, in seconds. Operating active components radiate heat, dead components don't. **Thermoprobe** is sensitive to  $\frac{1}{25}^{\circ}\text{F}$  change in temperature. A must for your workbench or field service. Order #209TM. **ONLY \$21.95 + \$3.00 shipping, NY Res. add tax (no COD's)** **BUYUS, INC., Dept. RE986, 10 White Birch Dr., Ossining, NY 10562, Visa or Mastercard (914) 762-4799.**  
CIRCLE 53 ON FREE INFORMATION CARD

# SERVICE CLINIC

## Customer psychology

EVERYBODY HAS HAD THIS EXPERIENCE: you're ready to fix a set, and suddenly you go blank! You look at the chassis, and it resembles a cake-pan full of firecrackers! When you go blank like that, there's only one thing to do: Get away from it for a while. Go drink a cup of coffee, or do something totally different for awhile. I know that method works; I've done it a million times myself.

### The LGC's

While you're away, what Hercule Poirot calls the Little Grey Cells in your brain will continue working. The LGC's keep working even though your conscious mind thinks that it's completely off the problem. If you're lucky, they'll come up with the right answer, or at least a more logical one. So, when you return, you can usually sit down and fix your set right away.

The subconscious mind is a very handy test instrument. Leave it alone and it will come up with the answer. The only things it can't fix are imaginary problems. And they're more real than you might think.

For example, a cranky old man had a TV set that seemed (to me) to be working perfectly. I was kneeling behind the set when suddenly he said, "There! There! What makes it do that?" I couldn't see that anything at all had happened.

So I tried a bit of psychology on him. I turned the AGC control up to the point where the picture became completely white. Then I said, "I can't tell how it looks from back here. You tell me when I get it right." I brought the AGC control

down a little at a time, and finally he said, "There, there! That's just right!" So my service call was really an exercise in Applied Customer Psychology—but it worked. The customer was satisfied, so I closed my tube caddy and went home.



FIG. 1

Another thing to watch out for is a situation like that pictured in Fig. 1. Try to establish a relationship with *one* customer—otherwise your LGC's may require servicing of their own!

It may be hard to satisfy a customer who insists on watching a distant, fading station. You'll just have to shoot from the hip. Try deliberately rotating the antenna (from outside, if necessary) away from the desired station. Next gradually bring it back on target. Then ask your customer, "How's that?" and chances are good that he'll say, "There. That's much better." When you hear that, you're in like flint.

That kind of trick only works with older sets, which have the contrast and AGC controls

mounted on the rear. If they're front-mounted, you'll have to figure out some other trick. And, wherever they're located, you'll just have to use whatever controls are present—and sometimes there aren't enough of them! Do the best you can with what you have to work with!

Of course, before you try psychology, make sure that the set really is working properly—after all, some TV's have real troubles. If you can't find anything else, clean all of the customer-operated controls (contrast, volume, etc.) so that they don't upset the picture when they're adjusted.

Fortunately, "picky" customers make up a very small percentage of the total population. But, when you run into one, you have to have a way to deal with him (or her). It's not easy, but it can be done. It may take a little extra time, but it's time well spent if the customer is pleased. And if he is pleased with you—and your work—he'll tell all the neighbors about you, and that's good for business. **R-E**

## SERVICE QUESTIONS

### NO HORIZONTAL SWEEP

*I have no horizontal sweep on an RCA CTC-71, just a straight vertical line. I changed the flyback; no improvement. Then I disconnected the tripler, the yoke, and the convergence panel; still no change. DC supply voltages are about normal. I'm completely confused. Help!—R. B., Toledo, OH.*

Say no more; help is on the way.



JACK DARR,  
SERVICE EDITOR



Look at your DC voltage readings, especially on the emitter of the horizontal output transistor. You should see +5.5 volts; since you read 0.0, the transistor is either open, or the bias is way off. Remove the transistor from the circuit and measure the DC resistance of all junctions, especially the collector-emitter junction. Chances are that it is open.

#### MISCONVERGENCE IN SONY

*I've got a Sony that's got me completely baffled. It has a good picture but the screens will not align! The red screen is a full inch to the left. Horizontal static has no effect. I've changed the convergence transformer; no luck. Is it the picture tube?—W.K., Lansing, MI.*

Well, you've got a dandy, and I'm sorry you asked! However, something is causing it. Just for luck, give it a good going-over with a degaussing coil, especially around the neck and the nearby parts.

Strictly from way out in left field, it could have been caused by a lightning strike near the set. I have seen sets that were affected by lightning strikes; for example, convergence on an American set with a triad gun was severely disrupted. Degaussing cured that one, and I hope it will help you. Good luck!

#### SCANNER BOOSTER

*Is it possible to amplify the signal before it is fed to a scanner? I live in an area where I need to increase the signal to get more audio. Can you tell me which type of antenna is best for signal gain?—T. W., Rogers, AR.*

Yes, you can use a booster like the ones used for TV. Just be sure to get one that covers your frequency band. The Capri unit you mentioned should probably work.

The highest-gain antenna is a Yagi. If you're not working very low frequencies, you might try one.

A Yagi has a dipole, a reflector behind it, and from one to three directors in front of it. You can find drawings and dimensions in any good antenna handbook. Otherwise, a dipole antenna with a reflector located  $\frac{1}{4}$  wavelength behind it is pretty sensitive. Aim it at a right angle to the desired signal.

**LOW VOLTAGE IN SANYO**  
*I've got a Sanyo 91C63. Several resistors were low in value so I replaced them. Now the power-supply voltage is lower than normal. I can't find any sign of a short, so I don't understand what's going on.—K. P., Zumbrota MN.*

This sounds like a problem we've had many times! Check the input filter capacitor. If it's open, or low in value, your B+ will be low with no sign of a short circuit. The capacitor doesn't have the capacitance to maintain voltage under normal load.

You can check that capacitor easily: Just bridge another one about the same size across it and see if the voltage comes back up.

#### FOREIGN RADIO

*I have acquired a radio that was made in Poland. It looks very much like a Grundig. I need service information and parts for it, especially a missing loopstick antenna. Can you help?—D. P., Ft. Dodge, IA.*

Probably not much, but I'll try. It could be a Grundig; look up the tube lineup and see if you can match it with a Grundig that you have a schematic for. Since all small radios are basically the same, that should give you enough information.

As for the loopstick, does the radio have a dial so that you can tell which bands it can receive? If it can receive the standard U.S. broadcast band, any loopstick should work. If not, try your signal generator. See which bands are covered by whistling them in. It should be fun (???) to get it going.

#### ZENITH COLOR COIL

*I have a Zenith 20Y1C50. When making the color adjustments, the phase-shift coil fell apart. I can't find a replacement for it anywhere. Zenith and Sams both list replacements which are themselves no longer available!—S. B., Bronx, NY.*

I see the coil (transformer, actually) you mean. It couples the color signal into the two color amplifiers. I haven't been able to locate a direct sub for that part, but it appears that a J. W. Miller part no. 6092 or GO-1099 might work. They're color circuit coils, and both have dual secondaries like yours.

## Capacitance, logic and more. For less.

Now, a fully-loaded DMM combines a capacitance meter, logic probe, and an hFE meter, all for the price of a DMM.

TTL Logic Probe: 20 MHz

Hi/lo/off indications

Detects 25nS pulse width

Capacitance: 5 ranges (2nF to 20 $\mu$ F)

hFE (NPN or PNP): 1 range (1000)

DMM: DCV-5 ranges (.2V to 1kV)

ACV-5 ranges (.2V to 750V)

DCA-4 ranges (200 $\mu$ A to 10A)

ACA-3 ranges (20mA to 10A)

Ohms-7 ranges (200 Ohms to 2000 Megohms)

Continuity beeper

Diode check

Built-in bail

Anti-skid pads

See one now at your local Beckman Industrial distributor.

**DM25L... \$89<sup>95</sup>\***



\*Suggested list price (\$US) with battery, test leads and manual.

**Beckman Industrial!**

Beckman Industrial Corporation  
A Subsidiary of Emerson Electric Company  
630 Puente Street, Brea, CA 92621  
(714) 671-4800

© Copyright 1985 Beckman Industrial Corporation

CIRCLE 98 ON FREE INFORMATION CARD

# Join the Electronics and Control Engineers' Book Club®

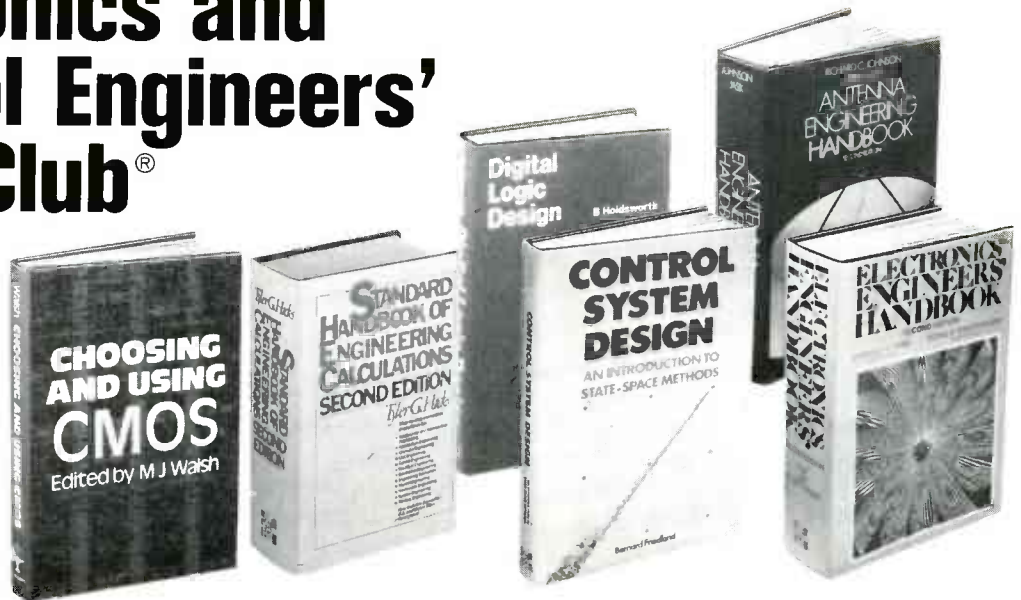

**DESIGNING ELECTRONIC CIRCUITS.** By R. G. Middleton. 351 pp., 192 illus. Covers virtually every category of circuits commonly used. This practical manual provides the basic design procedures, tables and formulas vital to effective electronic circuit design. Plus over 60 start-to-finish procedures are featured along with scores of computer programs to help you design and analyze electronic circuits. 583673-4 Pub. Pr., \$36.95 Club Pr., \$27.50

**POWER INTEGRATED CIRCUITS: Physics, Design, and Applications.** Edited by P. Antognetti. 544 pp., 410 illus. This comprehensive book offers an exceptionally thorough overview of the state of the art in design and technology—including the latest design advances in voltage regulators, audio amplifiers, power MOS devices, BiMOS power ICs, and improved transistor structures. 021/295 Pub. Pr., \$42.50 Club Pr., \$31.95

**TROUBLESHOOTING ELECTRONIC EQUIPMENT WITHOUT SERVICE DATA** By R. G. Middleton. 303 pp., 162 illus. and tables. Packed with charts, diagrams, and case histories, this practical handbook shows you how to pinpoint defective electronic circuitry when no service data is available. 583134-1 Pub. Pr., \$27.95 Club Pr., \$19.95

**STANDARD HANDBOOK OF ENGINEERING CALCULATIONS** T. G. Hicks, Editor in Chief. 2nd Ed., 1,468 pp., 1,292 illus. and tables. Now revised, updated, and considerably expanded, this huge handbook provides more than 5,100 step-by-step procedures for solving the kinds of engineering problems you encounter most frequently in your work. 287/35X Pub. Pr., \$59.50 Club Pr., \$44.50

**POWER CONTROL WITH SOLID-STATE DEVICES** By Irving M. Gottlieb. 372 pages, 218 illustrations. This comprehensive book discusses every type of solid-state device and circuitry now available for power electronics. It covers both the proven-in-practice power control systems and the avant garde—as well as some promising combinations of the older and newer devices and circuitries. 583240-2 Pub. Pr., \$28.95 Club Pr., \$21.95

**DIGITAL LOGIC DESIGN.** By B. Holdsworth. 338 pp., 192 illus. All of the recent advances in digital design techniques are presented here in depth. It's both a text covering basic concepts and a practical guide to design techniques for combinational, clock-driven, and event-driven circuits. 582852-9 Pub. Pr., \$39.95 Club Pr., \$27.50

**INTRODUCTION TO RADAR SYSTEMS** By M. I. Skolnik. 2nd Ed., 698 pp., 244 illus. Covering every radar fundamental and all important changes, this EE text exposes you fully to the systems themselves—and to their applications! Topics include radar equation, CW and frequency-modulated radar, MTI, pulse-doppler, tracking radar, receivers, displays, duplexers, noise, and more. 579/091 Pub. Pr., \$49.95 Club Pr., \$35.75

**ANTENNA ENGINEERING HANDBOOK, 2/e.** Edited by R. C. Johnson and H. Jasik, with contributions by 57 recognized authorities. 1,408 pp., 946 illus. This widely acclaimed Handbook gives you the guidance you need to solve problems in antenna design and application. 322/910 Pub. Pr., \$105.00 Club Pr., \$62.50

**HANDBOOK OF PRACTICAL ELECTRICAL DESIGN.** By J. F. McPartland. 416 pp., 300 illus. This volume provides a step-by-step explanation of designing electrical systems for industrial, commercial, and residential applications. 456/95X Pub. Pr., \$44.50 Club Pr., \$33.50

**ELECTRONICS ENGINEERS' HANDBOOK, 2/e.** Edited by D. G. Fink & D. Christiansen. 2,272 pp., 2,189 illus. This updated and enlarged edition covers all the latest knowledge in the field, including new advances in integrated circuits, pulsed and logic circuits, laser technology, telecommunications, and much more. 209/812 Pub. Pr., \$89.00 Club Pr., \$50.00

**CONTROL SYSTEM DESIGN: An Introduction to State-Space Methods.** By B. Friedland. 513 pp., illus. Covers feedback control, dynamics of linear systems, frequency-domain analysis, linear observers, linear, quadratic optimum control, random processes, and many other topics. 224/412 Pub. Pr., \$41.95 Club Pr., \$31.50

**FUNDAMENTALS OF LOGIC DESIGN AND SWITCHING THEORY.** By A. D. Friedman and P. R. Menon. 261 pp., 233 illus. Covering both theory and design techniques, this is an easy-to-understand introduction to the analysis and synthesis of digital circuits and their interconnection to create digital systems. 583601-7 Pub. Pr., \$26.95 Club Pr., \$21.50

**CHOOSING AND USING CMOS.** By M. J. Walsh. 304 pp., 155 illus. Offers a comprehensive overview of the semiconductor technology used... gives practical advice on circuit techniques to make your job easier. Specifications, characteristics and applications are included. 679/576 Pub. Pr., \$35.50 Club Pr., \$24.95

**THE ENCYCLOPEDIA OF ELECTRONIC CIRCUITS.** By R. Graf. 760 pp., 1,256 illus. This large volume provides circuits for virtually every type of application in 98 different categories. Each has a clear and concise explanatory text accompanying it. 583265-8 Pub. Pr., \$50.00 Club Pr., \$39.95

**TELEVISION ENGINEERING HANDBOOK.**—By K. B. Benson. 1,478 pp., 1,091 illus. Packed with the technical information and know-how you need to design, operate and maintain every type of TV equipment in current use. 047/790 Pub. Pr., \$89.50 Club Pr., \$62.50

**68000 MICROPROCESSOR.** By W. A. Triebel and A. Singh. 335 pp., 129 illus. This guide to Motorola's 68000 microprocessor uses a systems approach that includes extensive coverage of the 68000, its architecture, assembly language programming, and hardware interfacing techniques. 583613-0 Pub. Pr., \$34.95 Club Pr., \$26.95

**MICROPROCESSOR HANDBOOK.** Edited by J. D. Greenfield. 656 pp., 222 illus. This first-ever handbook helps you select the best microprocessor, enables you to understand the operation of a microprocessor you are now using and provides easily accessed coverage of the most popular 8 and 16-bit microprocessors currently available. 583636-X Pub. Pr., \$44.95 Club Pr., \$33.50

**McGRAW-HILL CONCISE ENCYCLOPEDIA OF SCIENCE AND TECHNOLOGY.** Editor-in-Chief S. P. Parker and the Staff of the McGraw-Hill Encyclopedia of Science and Technology. 2,065 pp., 1,600 illus. This volume serves every need for understanding today's science and technology. Written by over 3,000 of the world's topmost experts, including 19 Nobel Prize winners, it covers 75 disciplines from Acoustics to Zoology. 454/825 Pub. Pr., \$95.00 Club Pr., \$66.50

Get the competitive edge with the newest and the best information in your field . . . with books from all the leading publishers

New members!  
Any one of these great professional books for only \$289 as a premium with your 1st selection!

Spectacular values up to \$105.00

**CONTEMPORARY ELECTRONICS CIRCUITS DESKBOOK** *Compiled By H. Helms. 272 pp., 442 circuit diagrams.* Packed with clearly reproduced circuit diagrams, all proven-in-action, covering the entire spectrum of electronics technology. Each diagram includes a title, a brief description, type numbers or values for significant components and a citation of the original source.  
279/802 Pub. Pr., \$29.95 Club Pr., \$23.50

**MCGRAW-HILL ENCYCLOPEDIA OF ELECTRONICS AND COMPUTERS.** *By S. P. Parker, Editor-in-Chief. 960 pp., 1,266 illus., outsized 8 1/2 x 11 format.* It's a single-volume library that covers the entire world of electronics from Edison's pioneering work in electricity right up to optical fiber communications, control systems, lasers, radar, TV receivers, artificial intelligence, and computer storage technology.  
454/876 Pub. Pr., \$67.50 Club Pr., \$41.50

**COMPUTER METHODS FOR CIRCUIT ANALYSIS AND DESIGN.** *By J. Vlach and K. Singhal. 656 pp., 148 illus.* Computational methods have become an integral part of circuit analysis and design. And a solid understanding of the basics of computer-aided design is a must for engineers who want to achieve their career objectives.  
582855-3 Pub. Pr., \$46.95 Club Pr., \$35.95

**MODERN ELECTRONIC CIRCUITS REFERENCE MANUAL.** *By J. Markus. 1,264 pp., 3,666 circuit diagrams.* Complete with values of components and suggestions for revisions—plus the original source of each circuit in case you want additional performance or construction details.  
404/461 Pub. Pr., \$79.50 Club Pr., \$57.95

**STANDARD HANDBOOK FOR ELECTRICAL ENGINEERS, 11/e.** *By D. G. Fink and H. Beaty. 2,448 pp., 1,414 illus.* Today's most widely used source of electrical engineering information and data serves you as no other single work when you need detailed, timely, and reliable facts.  
209/74X Pub. Pr., \$85.00 Club Pr., \$51.00

**Be sure to consider these important titles as well!**

**DESIGN OF FEEDBACK CONTROL SYSTEMS.** *By G. H. Hostetter, C. J. Savant, and R. T. Stefani. 583206-2 Pub. Pr., \$41.95 Club Pr., \$31.45*

**MODERN COMMUNICATION CIRCUITS.** *By J. Smith. 587/302 Pub. Pr., \$43.95 Club Pr., \$32.50*

**MICROPROCESSOR SUPPORT CHIPS: Theory, Design, and Applications.** *By T. J. Byers. 095/183 Pub. Pr., \$43.50 Club Pr., \$35.25*

**DATA COMPRESSION: Techniques and Applications.** *By T. J. Lynch. 583267-4 Pub. Pr., \$44.50 Club Pr., \$31.25*

**DESIGNING DIGITAL FILTERS** *By C. Williams. 583627-0 Pub. Pr., \$36.95 Club Pr., \$27.95*

**ANALYSIS AND DESIGN OF DIGITAL INTEGRATED CIRCUITS.** *By D. A. Hodges and H. G. Jackson. 291/535 Pub. Pr., \$44.95 Club Pr., \$35.95*

**HANDBOOK OF OPERATIONAL AMPLIFIER CIRCUIT DESIGN.** *By D. E. Stout & M. Kaufman. 617/97X Pub. Pr., \$48.50 Club Pr., \$34.95*

**ENGINEERING MATHEMATICS HANDBOOK, 2/e.** *By J. J. Tuma. 654/298 Pub. Pr., \$41.50 Club Pr., \$31.00*

**DIGITAL COMMUNICATIONS.** *By J. Proakis. 509/271 Pub. Pr., \$45.95 Club Pr., \$32.95*

**CRYSTAL OSCILLATOR CIRCUITS.** *By R. J. Matthys. 583251-8 Pub. Pr., \$37.95 Club Pr., \$26.95*

**NEW DIGITAL TROUBLESHOOTING TECHNIQUES: A Complete, Illustrated Guide.** *By R. G. Middleton. 583351-4 Pub. Pr., \$24.95 Club Pr., \$18.75*

**INTRODUCTION TO RADIO FREQUENCY DESIGN.** *By W. H. Hayward. 383 pp., illus.* This comprehensive volume prepares you to actually design HF, VHF, and UHF equipment and enables you to follow much of the current literature. Structured equation sets make it easy to write programs for small computers or calculators.  
582748-4 Pub. Pr., \$27.95 Club Pr., \$22.95

**ELECTRONICS ENGINEERING FOR PROFESSIONAL ENGINEERS' EXAMINATIONS.** *By C. R. Hafer. 336 pp., more than 200 illus.* Actually two books in one—a quick preparation manual to help you pass your P.E. exams on the first try and a rich source of practical electronics engineering information and know-how.  
254/303 Pub. Pr., \$32.50 Club Pr., \$25.50

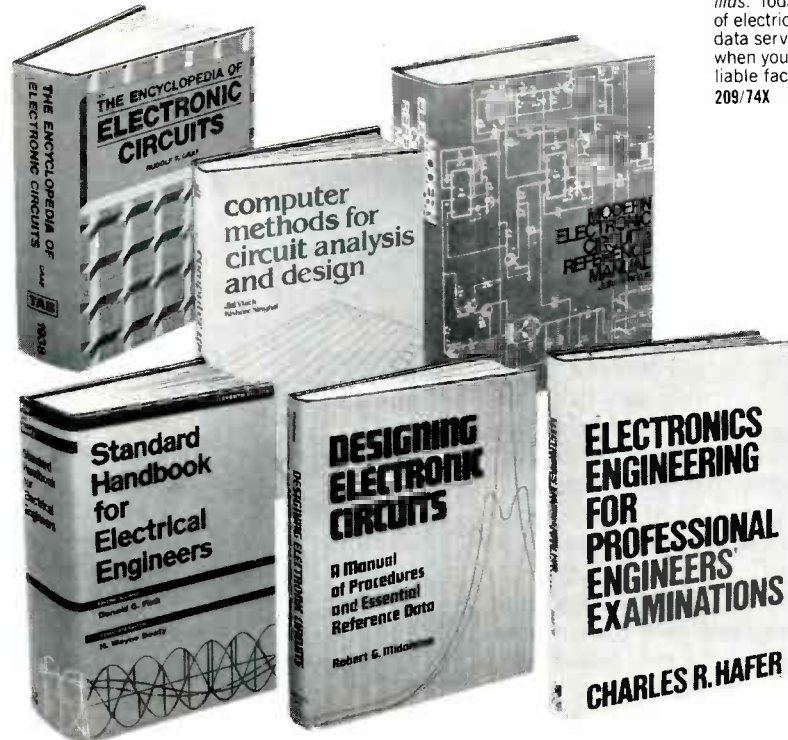

## Why YOU should join now!

- **BEST AND NEWEST BOOKS IN YOUR FIELD** — Books are selected from a wide range of publishers by expert editors and consultants to give you continuing access to the best and latest books in your field.
- **BIG SAVINGS** — Build your library and save money too! Savings ranging up to 40% or more off publishers' list prices—usually 20% to 30%.

**BONUS BOOKS**—You will immediately begin to participate in our Bonus Book Plan that allows you savings up to 70% off the publishers' prices of many professional and general interest books!

- **CONVENIENCE**—12-14 times a year (about once every 3-4 weeks) you receive the Club Bulletin FREE. It fully describes the Main Selection and Alternate Selections. A dated Reply Card is included. If you want the Main Selection, you simply do nothing—it will be shipped automatically. If you want an Alternate Selection—or no book at all—you simply indicate it on the Reply Card and return it by the date specified. You will have at least 10 days to decide. If, because of late delivery of the Bulletin you receive a Main Selection you do not want, you may return it for credit at the Club's expense.

As a Club member you agree only to the purchase of three books (including your first selection) during your first year of membership. Membership may be discontinued by either you or the Club at any time after you have purchased the first selection plus two additional books.

**Other McGraw-Hill Book Clubs:**  
Architects' Book Club • Byte Book Club • Chemical Engineers' Book Club  
• Civil Engineers' Book Club • Mechanical Engineers' Book Club

For more information, write to:  
McGraw-Hill Book Clubs, P.O. Box 582, Hightstown, New Jersey 08520-9959

### MAIL THIS COUPON TODAY

**McGraw-Hill Book Clubs**  
**Electronics and Control Engineers' Book Club®**  
P.O. Box 582, Hightstown, New Jersey, 08520-9959

Please enroll me as a member and send me the two books indicated, billing me for the \$2.89 premium and my first selection at the discounted member's price, plus local tax, shipping, and handling charges. I agree to purchase a minimum of two additional books during my first year of membership as outlined under the Club plan described in this ad. A shipping and handling charge is added to all shipments.

Write Code No. of \$2.89 selection here

Write Code No. of first selection here



Signature \_\_\_\_\_

Name \_\_\_\_\_

Address/Apt. # \_\_\_\_\_

City \_\_\_\_\_

State \_\_\_\_\_ Zip \_\_\_\_\_

This order subject to acceptance by McGraw-Hill. All prices subject to change without notice. Offer good only to new members.

E33816

# COMMUNICATIONS CORNER



HERB FRIEDMAN,  
COMMUNICATIONS EDITOR

## Communications wars

A FIERCE BEHIND-THE-SCENES WAR HAS raged for almost the entire 40-year history of radio communications. The war has been fought between the manufacturers of transmitting and those of receiving equipment. Sometimes it surfaces as an appeal to the FCC for some kind of regulation providing relief. At other times it has resulted in legal action between formerly friendly neighbors, or even in a western-type shoot-out.

The source of the dispute is RFI—Radio Frequency Interference. RFI is usually considered to be interference that is generated by something external to receiving equipment: for example, the hash that is sometimes induced in telephones by nearby personal computers.

Often, however, we use the term RFI to refer to interference generated within a receiver by an otherwise legal external source, even though that type of interference is not necessarily RFI in the true sense of the word. It is that pseudo-RFI which is really the problem in much consumer equipment, including tape recorders, telephones, TV's, VCR's, etc.

Pseudo-RFI can manifest itself in various forms including interference or image reversal in TV's, transmitter modulation in sound equipment and telephones, or cross-modulation products in receivers (wherein the listener hears stations to which the receiver is not tuned). Interference created by pseudo-RFI takes other forms, but those are usually considered the biggies.

Often, the cause of pseudo-RFI (and therefore the war for which it

is responsible) is not a radio or TV transmitter—which usually delivers a clean signal—but cost-cutting in the receiver.

### No filters

For many years, in order to trim a few dollars off the retail price of a piece of consumer equipment, much of the entertainment-equipment industry resisted installing filters. For example, until the advent of color TV it was highly unusual to find a "standard brand" TV that incorporated a lowpass filter in the tuner input to attenuate communication signals below 50 MHz.

Without the filter, an amateur, CB, or low-band VHF transmitter, or even a diathermy machine, could easily overload nearby TV front-ends and produce picture reversal or loss of synchronization. Although it is possible to keep the sub-50-MHz signals out of the TV by installing a highpass filter in the antenna lead-in (as shown in Fig. 1), unless the filter is properly installed—which is difficult when unshielded twinlead is used—radiation from strong local transmitters can be induced into the antenna lead-in *after* the highpass filter.

The term "shock-field" refers to the extremely strong RF energy in the immediate locality of a transmitter. Sound equipment that is located in the shock-field is particularly susceptible to RF, which can often bypass shielding. Problems generated by that RF usually manifest themselves as transmitter modulation heard in the background, or during quiet periods. Shock-field interference is even

known to have produced erroneous traces on a hospital's EKG recorder.

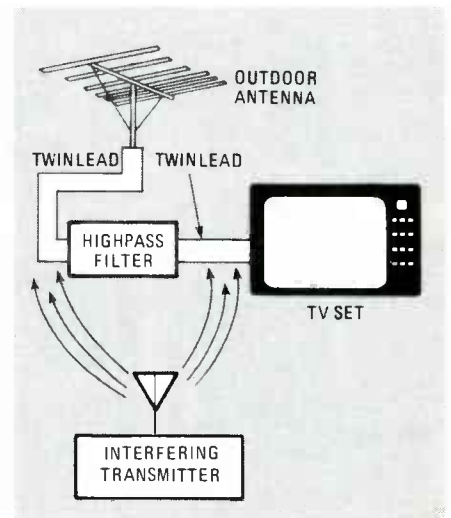

FIG. 1

In vacuum-tube amplifiers, whose high-impedance circuits are prone to RF interference, pseudo-RFI in audio amplifiers caused by local transmitters was filtered by brute force using filter chokes and capacitors in the wiring of the low-level preamplifiers.

It was hoped that the low impedances common to solid-state devices would alleviate the problem because, as a general rule, the lower a circuit's impedance, the less susceptible that circuit is to pseudo-RFI. Unfortunately, things didn't work out as hoped. The earliest circuit designs—many of which are still used today—employ transistors, and transistors consist of diode junctions. If there is enough RF energy in the circuit to cause the diode(s) to conduct, the stage becomes a rectifier, a broadband amplifier, or both. If

# KENWOOD

...pacesetter in Amateur radio

## Scan the World



### R-2000 All-mode receiver

Superior engineering, quality, and performance describe Kenwood's multi-mode communications receiver.

The R-2000 receiver has the most often-needed features for the serious or casual shortwave broadcast listener. Listen in on overseas news, music, and commentary. "Listen up" on the VHF public service and Amateur radio frequencies, as well as aircraft and business band communications with the R-2000 and VC-10 option. The R-2000 has a muting circuit so you can monitor your Amateur radio station's signal quality.

- Covers 150 kHz–30 MHz in 30 bands.
- All mode: USB, LSB, CW, AM, FM.
- Digital VFO's. 50-Hz, 500-Hz or 5-kHz steps. F. LOCK switch.

- Ten memories store frequency, band, and mode data. Each memory may be tuned as a VFO.
- Lithium batt. memory back-up.
- Memory scan.
- Programmable band scan.
- Fluorescent tube digital display of frequency (100 Hz resolution) or time.
- Dual 24-hour quartz clocks, with timer.
- Three built-in IF filters with NARROW/WIDE selector switch. (CW filter optional.)
- Squelch circuit, all mode, built-in.
- Noise blanker built-in.
- Large front mounted speaker.
- RF step attenuator (0-10-20-30 dB.)
- AGC switch. (Slow-Fast)
- "S" meter, with SINPO scale.
- High and low impedance antenna terminals.
- 100/120/220/240 VAC operation.
- RECORD output jack.
- Timer REMOTE output (not for AC power).
- Muting terminals.

#### Optional accessories:

- VC-10 VHF converter for R-2000 covers 118-174 MHz
- YG-455C 500 Hz CW filter for R-2000
- HS-4 Headphones
- HS-5 Deluxe headphones
- HS-6 Lightweight headphones
- HS-7 Micro headphones
- DCK-1 DC cable kit for 13.8 VDC operation

Additional information on Kenwood all-band receivers is available from authorized dealers.



## KENWOOD

TRIO-KENWOOD COMMUNICATIONS  
111 West Walnut Street  
Compton, California 90220

CIRCLE 102 ON FREE INFORMATION CARD

Service manuals are available for all receivers and most accessories.  
Specifications and prices subject to change without notice or obligation

## COMMUNICATIONS CORNER

continued from page 84

the interference is caused by an AM transmitter, the RFI is detected just as it would be in an old-fashioned crystal radio, and the interference will be crystal clear (pun intended).

If the stage is a high-gain preamplifier, such as a magnetic phono preamp, and the interference is caused by a local low-band VHF (FM) transmitter, the listener hears the VHF transmitter's FM modula-

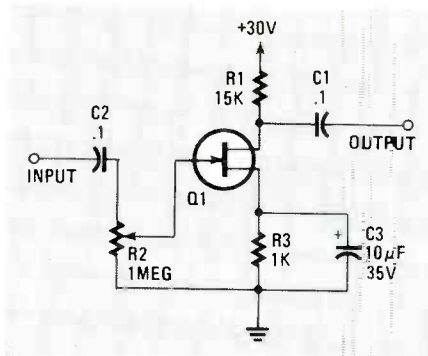

FIG. 2

tion in the background because, since the diode junction is non-

linear, it functions as a slope detector that will produce audio output from an FM signal.

If the stage is an RF amplifier, the diode causes it to function as a mixer that will output sum and difference signals, as well as the original input signal. Between the sum and difference frequencies many other frequencies may appear as by-products of the heterodyne (mixing) process. The result is that the listener may be subject to a garble of signals, or intermittent bursts of interference from strong local transmitters of any kind.

Much arm-twisting by industry groups and the FCC has convinced many manufacturers of consumer equipment to include various kinds of filters to prevent pseudo-RFI from lessening or destroying signal quality. However, stupidity—or just plain stubbornness—still reigns supreme among some circuit designers. For example, it is easy to design audio preamplifiers using FET's because it's usually easier to *bridge* the output of one stage with a circuit that has a high-impedance input than it is to *match* the impedance of that stage. In fact, any reasonably competent junior high school student could design a totally bridged amplifier.

Figure 2 shows the simplified circuit diagram of a preamplifier used in a recently-introduced consumer device. The input device is a FET, whose effective input impedance in this application is as high as a vacuum tube's input impedance. Although bridging with a FET is cheap and saves on circuit design time, it is precisely that kind of thinking which has produced the 40-year war between the users of communications equipment and those who watch TV, listen to the radio, and to recordings. The point is that, in this age of low-impedance devices and circuits, we must question the wisdom of anyone using that type of design, because the circuit is extremely sensitive to RF-pickup.

And it's ironic that the most difficult part of the problem is explaining to someone why the interference is caused not by your amateur, CB, or VHF rig, but that person's poorly-designed \$3000 entertainment center. **R-E**

## THE ONE SCANNER THAT'S REALLY GOING PLACES.



The Fox BMP 10/60™ is the only scanner that goes everywhere. You can use it at home, on the road, even as a battery-operated portable.\* Police, fire, mobile phone and weather are just a few of the action-packed frequencies you can listen in on. The BMP 10/60 is easy to program and it's ideal for both personal and professional use. For

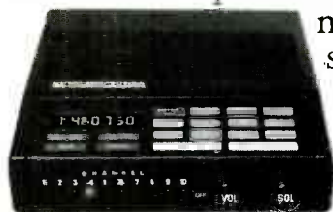

### FOX® BMP 10/60 BASE/MOBILE/PORTABLE SCANNER

\* with optional Porta-Pac

more information about the scanner that's going places, call 1-800-543-8000,

Dept. M-779.  
Fox Marketing.



## LETTERS

continued from page 22

stating, albeit obliquely, that there could be something beyond the realm of known physics that influences the Kirlian "aura."

The generation of Kirlian images, although a complex process subject to many variables that are not easily controlled, even in the laboratory (e. g., pressure, temperature, conductive residues deposited by the object being tested—or left over on the electrode from the previous object, exposure time, etc.), is explainable without invoking the paranormal.

For readers who would care to learn more about the physical aspects of Kirlian photography, an excellent study was published in the Spring issue of *Skeptical Inquirer*, a quarterly that is published by the Committee for the Scientific Investigation of the Paranormal (CSICOP).

Also, several years ago, in the trade journal *Functional Photography*, an article presented a fairly convincing theory of how the Kirlian corona interacts with the dyes in color film to yield those complex images.

I really enjoy *Radio-Electronics* magazine, particularly the construction projects. However, it's bad enough that Kirlian photography, pyramid power dowsing, and other such stuff get favorable coverage in the news media and supermarket tabloids. Let's at least try to keep it out of informed technical publications.

STEVE HANSEN,  
Amherst, NH

### MODULAR ROBOTS

I've been waiting for you to cover robots. It's took awhile, but you did it right in the March 1986 *Radio-Electronics*.

I'm an electronics technician (U. S. N.) by vocation, but I'm also an electronics hobbyist, because I want toys and tools that do more but cost less. I'd love to see you build on the March issue and do with robots what you've done with TV decoders, power supplies, and virtually everything else. I'd like to see plans and ideas for homebrew modular robots.

All told, it could be a big project, and could keep a regular department full for years to come. I'm sure that I'm not the only reader who's willing to submit hints, help, and new ideas. My plans are to start with a microprocessor-controlled base (rover type) then add various modules such as body, brain, various sensors, manipulators, interfaces etc.

Along those lines, there are many, many projects that I would like to see, and some are yet to be

thought up!

Right now, the robot industry is "backyard" at best. I'd like to see the hobbyists, not Daddy Warbucks, make the robot a household *tool*. The computer industry will easily fall into place with software and interfaces. The robot will develop faster and farther if homebuilts have more in common than so-called standard RS-232 interfaces, or dialects of BASIC.

SCOTT ZINN

Souda Bay Creek, NY

R-E

## CABLE TV SPECIALS

### CONVERTERS

★

JERROLD:	DRZ-3DIC105—66 Channel Wireless .....	\$199. <sup>95</sup>
	JRX-3 DIC—36 Channel Corded Remote.....	\$149. <sup>95</sup>
	JSX-3 DIC—36 Channel Set Top .....	\$129. <sup>95</sup>
	SB-3—'The Real Thing' .....	\$119. <sup>95</sup>

MAGNAVOX:	6400—60 Channel Wireless w/Parental Lockout for Jerrold systems.....	\$199. <sup>95</sup>
-----------	---	----------------------

ZENITH:	Z-TAC Cable Add-On.....	\$225. <sup>00</sup>
---------	-------------------------	----------------------

VIEW STAR:	EVSC-2000—60 Channel Wireless— with Parental Lockout.....	\$ 99. <sup>95</sup>
------------	--	----------------------

	EVSC-2000A-B—Same as above with A-B Switch .....	\$109. <sup>95</sup>
--	---	----------------------

	View Star 1000—60 Channel Wireless..... with Volume .....	\$119. <sup>95</sup>
--	--	----------------------

### MISCELLANEOUS

OAK:	N-12 Mini-Code .....	\$ 89. <sup>95</sup>
	N-12 Mini-Code Vari-Sync .....	\$109. <sup>95</sup>
	N-12 Mini-Code Vari-Sync Plus Auto On-Off ..	\$165. <sup>00</sup>

JERROLD:	400 & 450 Handheld Transmitters.....	\$ 29. <sup>95</sup>
----------	--------------------------------------	----------------------

HAMLIN:	MLD-1200 .....	\$ 99. <sup>95</sup>
---------	----------------	----------------------

NEW ITEMS:	Standard Components—66 Channel Wireless- with Parental Lockout	\$ 99. <sup>95</sup>
------------	---	----------------------

Scientific Atlanta .....	Call for Price
--------------------------	----------------

Power Zapper Stun Gun, 46, 000V .....	\$ 59. <sup>95</sup>
---------------------------------------	----------------------

K-40 Radar Detector—Dash Model .....	\$199. <sup>95</sup>
--------------------------------------	----------------------

K-40 Radar Detector—Remote .....	\$229. <sup>95</sup>
----------------------------------	----------------------

ALL UNITS GUARANTEED. QUANTITY PRICES AVAILABLE.

## UNITED ELECTRONIC SUPPLY

P.O. BOX 1206 • ELGIN, ILLINOIS 60121 • 312-697-0600

CIRCLE 183 ON FREE INFORMATION CARD

# ANTIQUE RADIOS

## Speakers and headphones

THIS MONTH WE'LL DISCUSS VARIOUS kinds of audio output devices including headphones, electro-dynamic, magnetic, and permanent magnet speakers, and troubleshooting information about each type of reproducer. But before we get to all of that, let's take a look at the antique of the month.

### Looks good, doesn't work

Early Zenith console radios like the 1940-ish model shown in Fig. 1 were very popular in their day, and many of them still are. That Zenith could receive several different bands, and it has a tuning eye and assorted tone controls. That particular radio was chosen to make a point. Although it's in good outward condition, it will never play again. It is beyond repair because it has no tubes, no speaker, and a burned out transformer. But even though it's useless—as a radio—to a collector, it still has value as a display piece. For example, it could be used as a prop in a play or TV show.

The Zenith will be donated to the Golden Radio Buffs of Maryland, Inc. That organization doesn't collect radios and equipment; their interest is in broadcasting and personalities. They have a display at the Museum of Industry in Baltimore, MD. A few antique radios are on display there to set the mood while recordings of early radio programs are played. If you are interested in joining the Golden Radio Buffs, send an SASE to Gene Leitner at 7506 Iroquois Ave., Baltimore, MD 21219.

### Speaker history

Reproducers, like all chassis



FIG. 1

components, have seen many refinements over the years, although the major innovations were mostly completed during the 1920's. As with most advances in radio, it's difficult to say who invented the loudspeaker. And, as in other areas of electronics, the names of many early experimenters are undoubtedly lost.

There are three basic types of speakers: magnetic (not to be confused with either of the following types), dynamic (also called electro-dynamic), and PM (Permanent Magnet). The names of the various types of speakers can be confusing. The names of magnetic speakers, for example, have many variations including the dynamic magnetic, diaphragm and horn, cone and armature, etc. Although all speakers operate magnetically, remember that the "magnetic"



RICHARD D. FITCH,  
CONTRIBUTING EDITOR

type of speaker differs from the other types in several significant ways. We'll discuss those differences below.

The earliest reproducers were headphones, but by the mid 1920's, magnetic horn-type speakers had supplanted earphones. Then came cone-type speakers, both single and double. And by 1930 the electro-dynamic loudspeaker was the most popular audio output device. Later, the development of new alloys brought about the permanent magnet, which simplified radio circuitry, because PM speakers don't require a field coil (which is discussed below).

Early radios were often sold without tubes, chassis, or speaker; in fact, the schematics of many early radios seldom indicate anything after the audio output tube. The manufacturers left it to the consumer to decide which type of reproducer to use, and great debates raged regarding the merits of various types of speakers. And, because radios often came without speakers, the manufacture of speakers and cabinets, as well as headphones, constituted a thriving business of its own. An example of each of the four major types of reproducer is shown in Fig. 2. Clockwise from the lower left are headphones, a magnetic speaker, a dynamic speaker, and a PM speaker.

Early headphones were made by about half a dozen manufacturers, and all were basically the same. The headset shown in Fig. 2 is from about 1920 and was probably designed to be used by a telephone operator. It was made by C.



Brandes, Inc., of New York; that company later made speakers and radios too. The Brandes headset is more collectable than many antique radios.

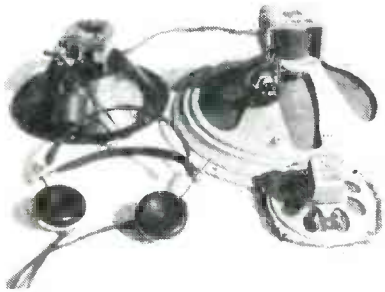

FIG. 2

That magnetic headset operates by means of a diaphragm that is suspended above a magnet. Coils wound around the magnet cause the diaphragm to vibrate when current flows through those coils.

Headphones have survived to the present day, but after speakers became generally available, they proved to be much more popular than headphones. Why did speak-

ers become so popular? One reason is that the earphone cord severely restricts your freedom of movement. And only one person can listen at a time, although two friendly listeners can share a set of earphones if they put their heads together.

So designers began thinking of better ways for people to enjoy radio broadcasts. One method was simply to lay the headphones on a table and strap a megaphone to an earpiece. That method worked and was probably the beginning of the loudspeaker. But of course it left much to be desired, so designers continued their search for a more perfect reproducer.

### Speakers

One early attempt at better sound reproduction is the magnetic speaker. There are many varieties of magnetic speaker, but, in general, a magnetic speaker uses an armature to move a diaphragm, although some use an earphone coil and a cone or a horn attached to the diaphragm.

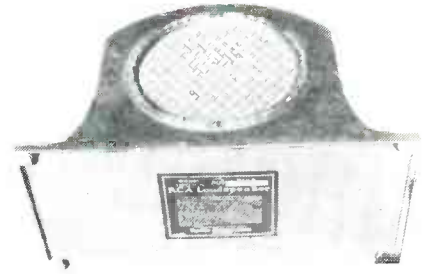

FIG. 3

Magnetic speakers, especially the various horn types, were popular during the mid 1920's. One very popular magnetic speaker was RCA's model 100-A, which is shown in Fig. 3. There are still thousands of those speakers around, and many collectors have one or more.

The electro-dynamic speaker became popular in the late 1920's and early 1930's. It requires a DC voltage to operate a field coil, which, as its name suggests, generates the magnetic field that, in conjunction with the voice coil, causes the cone of the speaker to move. That field, of course, is gen-

# HAMEG

## Instruments

Scope and new  
**Modular System 8000**  
to make a compact test set-up

HAMEG's range of oscilloscopes is complemented by a growing number of measuring and generator modules, fitting in a matching mainframe with power supply.

**2-year warranty**

**HAMEG Inc.**  
88-90 Harbor Road · Port Washington N.Y. 11050  
Phone (516) 883.3837 · TWX (510) 223.0889

CIRCLE 62 ON FREE INFORMATION CARD

# SUPER LONG PLAY TAPE RECORDERS

10 Hour Model — \$95.00\*  
14 Hour Model — \$159.00\*

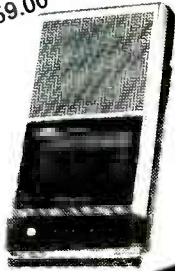

Modified Panasonic Slimline, high quality. AC-DC Recorders provide 5 or 7 continuous hours of quality recording & playback on each side of cassette for a total of 10 or 14 hours depending on model. Built-in features include • Voice level control. • Digital counter, etc. TDK DC 180 Cassette Furnished.

## PHONE RECORDING ADAPTER

Records calls automatically. All Solid state connects to your telephone jack and tape recorder. Starts recording when phone is lifted. Stops when you hang up.



\$24.50\*

FCC APPROVED

**VOX VOICE ACTIVATED CONTROL SWITCH**  
Solid state. Self contained. Adjustable sensitivity. Voices or other sounds automatically activate and control recorder. Uses either recorder or remote mike \$24.95\*



\*Add for ship & hdg. Phone Adapter & Vox \$1.50 ea. Recorders \$4.00 ea. Cal. Res. add tax. Mail order. VISA/M.C. COD's OK. Money Back Guarantee. Qty. disc. avail. Dealer inquiries invited. Free data.  
**AMC SALES INC.** Dept. A 9335 Lubec St., Box 928, Downey, CA 90421 (213) 869-8519

CIRCLE 108 ON FREE INFORMATION CARD



# TUBES and IC's FAST DELIVERY

## LOWEST PRICES

call Toll Free (800) 221-5802

In-depth Inventory - Industrial & Receiving Tubes  
Here are 2 dozen examples

3-500Z	85.00	8122	135.00
572B	75.00	MRF450	12.95
811A	15.00	MRF492	19.95
3146B	8.75	6LF6	8.26
M2057	15.00	6JS6C	7.46
8950	12.50	6CA7	6.91
4CX250B	75.00	SD1088	17.95
6883B	9.50	2N3055	.70
PL259	10/4.95	2N6084	11.95
PL258	10/7.95	UG175/176	10/1.55
M358	2.25	UG255/U	1.55
813	45.00	UG273	2.20

Major Manufacturers Factory Boxed and Full line of Sylvania ECG Replacement Semiconductors



Minimum order \$25.00

Allow \$3 UPS charge

## TRANSLETERONIC INC.

Box R, 1365 39th Street, Brooklyn, NY 11218  
Tel. 718-633-2800/Watts Line 800-221-5802  
FAX # (718) 633-4375

CIRCLE 202 ON FREE INFORMATION CARD

erated in later speakers by a permanent magnet. The dynamic speaker also includes a hum-bucking coil that cancels hum introduced by the field coil.

### Pros and cons

There was much discussion of the relative merits of various types of speakers in the late 1920's when the popularity of the dynamic type was increasing. Proponents of dynamic speakers focused on the faults of the magnetic units, which are really just glorified earphones that produce weak, scratchy sound. They are, however, excellent collectables today. The main advantages of the magnetic units are their lower initial cost and their lack of hum.

But, by the late 1920's, most listeners used dynamic speakers and never noticed the hum. And after a listener heard a dynamic speaker, it was difficult to return to a magnetic speaker.

However, economics sometimes caused a listener to buy a magnetic rather than a dynamic speaker, because the latter often required a separate power pack (with rectifier) to drive the field coil. Of course, a well-informed consumer knew that there was no need to purchase a separate power pack if his radio's chassis had provisions for a field coil built in.

Proponents of magnetic speakers pointed out that it was an advantage not to have to drive a field or hum-bucking coil. No storage battery, rectifier, or filter was needed. And since no hum was introduced, there was no need for a hum-bucking coil.

On the other hand, a magnetic speaker had problems reproducing low notes. Even with a large horn or cone, it couldn't match the frequency response of a dynamic speaker. Most people agreed that magnetic speakers sufficed for telephone use (which is where they began), but not for musical reproduction. The slight hum produced by a dynamic speaker was preferable to lack of fidelity.

Receiver manufacturers who didn't supply a reproducer with a receiver usually recommended that the consumer buy the more expensive unit, because that made

the receiver itself seem better, so the consumer would be more likely to recommend that brand to other people.

Radios made by Zenith, Radiola, Bremer Tully, and others could use various types of speakers. Magnetic speakers were more popular with early battery-operated sets such as those made by Dayton and Radiola. Some radios had both a jack for a magnetic speaker and terminals for a dynamic speaker.

### Troubleshooting headphones

There is little that can go wrong with magnetic headphones electrically. So first check a troubled set mechanically. Remove the caps on the earpieces. The diaphragm should fall out—and maybe a few other things besides. Remove any dust, dirt, or other foreign objects, because they can prevent the diaphragm from vibrating.

The coil connections should be clearly visible, so make a continuity test between the terminals and the plug. The coils may be open, but that's unlikely. The splice leading to the other earpiece is a likely suspect if one side of the headset is dead. When you re-assemble the earpieces, pay attention to the diaphragm. Some have a painted side which should face out.

### Troubleshooting PM speakers

Unlike the complicated speaker array of early radios, small PM speakers can be checked quickly, and they have few components that can go bad. The voice coil (also called the moving coil) and the audio output transformer are the primary sources of trouble. Others include an off-center voice coil, a warped cone, and a bent frame, all of which will distort the sound. The labor involved in trying to straighten a cone or frame, or center a voice coil, simply isn't worth the effort. Just replace the entire speaker. But if the results of a continuity test are negative, don't assume that the voice coil is bad. The trouble is most likely at a terminal, plug, or other soldered connection. The voice coil rarely develops an open in the winding.

If you're not sure whether the speaker or some other component is at fault, the easiest way to

check a small PM speaker is by substitution. Just make sure that you connect the speaker to the secondary of the output transformer. Some transformers are mounted on the chassis, and others are mounted directly on the speaker frame.

You may be able to salvage a seemingly open output transformer. If a winding fails a continuity test, the problem may be a solder joint. Just peel back some of the insulating paper to where the winding wire joins the hookup lead. If you don't find a bad joint there, it's usually cheaper to replace the transformer than to repair it.

### Troubleshooting magnetic speakers

Many repairs required by magnetic speakers are mechanical. If the driving rod is loose, it may only require tightening the nut. If the center of the cone is torn, remove the rod and re-glue the cone. Repairing that type of cone is much easier than trying to attach a torn cone to the voice coil of a dynamic speaker.

Since a magnetic speaker is built like an earphone, it can be checked like an earphone. Continuity can be measured between the coil terminals and the plug. Remove any dirt or dust that may interfere with operation of the diaphragm. The pin connected to the diaphragm and to the center of the cone often breaks loose. A little glue around the area should fix it.

An armature-activated magnetic speaker might have a problem with the armature's striking the pole pieces. That generates an easily-identifiable sound that occurs mostly on low notes. Those pole pieces, by the way, are partly what limited the popularity of that type of loudspeaker. Many people found the mechanical adjustments more trouble than they were worth.

### Troubleshooting dynamic speakers

A dynamic speaker may suffer from any problem that a PM speaker may suffer from, in addition to several of its own. Unwanted vibrations could be caused by a torn cone, dirt or metal particles,

loose mounting screws, or other metal components on the loudspeaker's frame. Unlike PM speakers, most dynamic units provide a means of centering the voice coil.

That is done with a device called a spider, which comes in several variations. Besides centering the voice coil, the stiff material the spider is made of helps the voice coil return to its neutral position when no signal is applied. When centering the voice coil with a spider, sometimes it helps to place some stiff paper around the coil. Doing that helps ensure that the coil won't rub after the spider is adjusted.

Unfortunately, you'll probably have to make every effort to repair a damaged speaker cone yourself. The old speaker reconer is a dying breed.

Hum problems are easy to diagnose. A hum bucking coil is wired in series with the secondary of the output transformer and the voice coil. When disconnecting the voice coil or output transformer leads, be careful not to reverse them in relation to each other. You

*continued on page 93*

## Power Supplies Discount Prices!

### VERSATILE LAB POWER SUPPLY



ELECTRO INDUSTRIES MODEL 3002A

Reg. \$125.00 Sale Price **\$99<sup>95</sup>**

• 0-30 VDC at 0-2A • Fully adjustable current limiting • Constant voltage/constant current modes — automatic crossover • Excellent regulation with low ripple • Floating output • Built-in short-circuit and overload protection. Options: 10-Turn Voltage & Current Controls, \$25 each. Both for \$45.

### EPSCO MODEL EC-2 POWER SUPPLY

• 0-16 VDC at 5A • Comb. V/A meter • Benchtop • 1.8 volt/amp load change • 0.5% ripple @ 5A

Reg. \$169.50 Sale Price **\$130<sup>00</sup>**

Check, Money Order or C.O.D. Add \$4.50 per unit for shipping & insurance. Outside U.S. \$9.00. IL residents add 7% tax. 15-Day Money Back Guarantee.

### Salen Enterprises

P.O. Box 915, Morton Grove, IL  
60053 Area 312-465-1424

CIRCLE 185 ON FREE INFORMATION CARD

### Learn the IBM PC's secrets with the MICROPROFESSOR 1/88



Students, engineers, or technicians—  
Now you can learn micro-processing and understand the technology which made the IBM PC famous.

#### The MPF-1/88 features:

- extensive documentation
- 16-bit central processor
- full-size keyboard
- special options

Three tutorial guides cover all capabilities. The ideal training tool! If the IBM PC or micro-processing are in your future, you owe yourself an MPF-1/88. Invest now!

Only **\$349.95**

Plus—

- Check this box for a FREE MPF-1/88 tutorial textbook when you order within 7 days. \$24.95 value

**ETRONIX**

Dept. 09-86  
5326 9th Ave. NE  
Seattle, WA 98105-3617

For immediate action call TOLL FREE:  
**1-800-426-1044**

Full money back guarantee.



CIRCLE 176 ON FREE INFORMATION CARD

## ATTENTION! ELECTRONICS TECHNICIANS

EARN YOUR  
**B.S.E.E.  
DEGREE**



### THROUGH HOME STUDY

Our New and Highly Effective Advanced-Placement Program for experienced Electronic Technicians grants credit for previous Schooling and Professional Experience, and can greatly reduce the time required to complete Program and reach graduation. No residence schooling required for qualified Electronic Technicians. Through this Special Program you can pull all of the loose ends of your electronics background together and earn your B.S.E.E. Degree. Upgrade your status and pay to the Engineering Level. Advance Rapidly! Many finish in 12 months or less. Students and graduates in all 50 States and throughout the World. Established Over 40 Years! Write for free Descriptive Literature.

## COOK'S INSTITUTE OF ELECTRONICS ENGINEERING

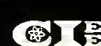

347 RAYMOND ROAD  
P.O. BOX 20345  
JACKSON, MISSISSIPPI 39209

CIRCLE 205 ON FREE INFORMATION CARD

# DRAWING BOARD

Program corrections and lab set-up



ROBERT GROSSBLATT,  
CIRCUITS EDITOR

LISTING 1—CORRECTED PROGRAM

Address	Op Code	Source Code	Comments
0000	AF	XOR A	Zero the Accumulator
0001	26 0F	LD H,0F	Set the display number
0003	2E A0	LD L,0A	Set the loop counter
0005	7C	LD A,H	Load the Accumulator
0006	D3 FF	OUT (FF),A	Send it to the latch
0008	C3 00 11	JP 0011	Go to delay subroutine
000B	25	DEC H	Decrement port count
000C	2D	DEC L	Decrement loop counter
000D	C2 05 00	JP NZ 0005	Do again if not zero
0010	76	HALT	End of the program
0011	11 83 8B	LD DE,5161	Preset the delay loop
0014	1B	DEC DE	Decrement the counter
0016	B3	OR E	OR with the low byte
0015	7A	LD A,D	Transfer the high byte
0017	C2 14 00	JP NZ 0014	Jump back if not zero
001A	C3 0B 00	JP 000B	Return if finished

IT HAPPENS TO EVERYONE. I GOOFED when putting together the demonstration program for the Z80 circuit in the March 1986 issue. I'm glad that several of you caught the mistakes and let me know about them, but I'm also a bit disappointed that only three people let me know about it. Just for the record, if anybody sees what even looks like an error on my part, I'd be grateful if you'd take the time to drop me a card and point it out to me. The only way we'll profit from our discussions is to make sure that all the information presented here is correct.

The three people who found mistakes are Paul Fargen of Louisville, KY, L. Barker of Chicago, IL, and Steven Gray of Orlando, FL. Some of the points they made are real screw-ups on my part, one is a typo, and the last is a matter of opinion. We'll deal with the out-and-out mistakes first.

## Delay loop

The worst error occurred in lines 11-14, a delay loop that was supposed to let the LED display remain stable for about half a second before displaying the next value. My first mistake was in calculating the number of T cycles needed to go through the loop. I said that 14 were needed but in actual fact the delay loop takes 16 T cycles. The DEC DE instruction in line 12 takes 6, and the JP NZ instruction in line 13 takes 10 cycles.

But even with the loop counter loaded with the correct number (in line 11), there was still a major problem. After the program entered the delay loop it would loop there forever. The reason is that the DEC DE instruction has no effect on the zero flag, and the zero flag is what we test to find out whether we can exit the delay loop. The program would continue decrementing the DE regis-

ter until reset, power-down, etc. The result would be that all the LED's on the output port would light up and stay lit.

There are several ways to correct the problem. Probably the simplest approach involves realizing that when the loop counter reaches zero, both the D and the E registers will be zero. So, as shown in lines 13-15 of Listing 1, all we have to do is OR the two registers with each other and test for a result of zero. If so, the program will jump back to the main display routine. However, adding the extra lines of code forces us to change the value we stored in DE to control the delay loop.

The 16 T cycles we had in the original loop increase to 24 because the LD A,D and the OR E each take four T cycles. A half-second delay means we want to wait 500,000 microseconds. Dividing that by 24 gives us 20,833 decimal or 5161 hex. Line 11 of the program loads that value into the DE register pair.

Of course, the Z80's instruction set is rich enough for you to find several other ways of fixing the original program to correct the mistake in the delay loop. As a matter of fact, figuring out other ways to solve the problem is a good exercise in programming!

## Typo

There was a typo in line 3 of the original listing. The code printed in the column was LD A,A0. That's where we set the number of times we want the program to loop through the hex display. As it is, the program would loop through the display procedure 160 times.

What happened was that the two digits were reversed; the correct value should have been 0A. Then the program would loop ten times, as I called for in the text.

### No RAM

Steve Gray also mentioned, as I did, that in RAM-less circuits the Z80 cannot use instructions that use the stack, so PUSHes, POP's, CALL's, and interrupts can't be used. Although the demonstration program avoids that problem by using JUMP's, an alternative would have been to stash calling addresses in one of the other Z80 registers such as the IX or IY. Why not try that approach as it's a good exercise?

### Programming style

The last comment I got in the mail was about the first line of the program, XOR A. Since the accumulator is loaded with a value in line 4 of the program, there's no real reason to zero it when the program starts.

Now I'm the first one to admit that the real hallmark of slick software is economy. Nobody gets more of a kick out of hacking bytes off a listing than I do. And when you deal in the real world where speed and memory constraints are very important considerations, an extra few bytes or so here and there can mean the difference between a working program and an embarrassment.

On the other hand, good programming skills (or skills of any sort), only come about by developing good habits, such as zeroing a register at the beginning of a routine, or preserving the environment before jumping to a sub-routine. Unfortunately, habitual operations like those can't be applied blindly. Our XOR A doesn't hurt operation of the program, but it is unnecessary and can be deleted if you wish.

In our original discussion of the program, I stated Grossblatt's Fourth Law: *You have to know the rules to break the rules.* Let's put that another way: In the beginning you do it by the book, and when you think you know the book, you want to throw it out the window. But then again, it's probably better not to.

R-E

## ANTIQUE RADIO

*continued from page 91*

could end up with twice as much hum. To determine whether the hum bucking coil is operating, just bypass it with a piece of insulated wire. If the hum level increases, the coil is working. However, if the hum level decreases, check for a reversed connection.

While we try to maintain the authenticity of our antique radios, sometimes we have to use not-quite-original replacements. For example, you might have to replace a dynamic speaker that is beyond repair with a PM speaker. You can connect the voice coil of the PM unit directly to the output transformer. You don't have to worry about the hum bucking coil, but you may have to connect a resistor or a choke to the point where the field coil was wired. As mentioned above, some chassis allow you to use a PM speaker just by disconnecting the field coil leads. Check your schematic.

If you're troubleshooting an AC/DC radio, in which the output plate current flows through the filament of the pilot lamp, you can spot an open voice coil (or a bad solder connection) by watching the pilot lamp. With the volume turned up full, the light should flicker when you tune in a strong station. That's due to varying plate current flowing through the pilot lamp. If it flickers, but you get no sound output, disconnect one speaker lead and check the continuity of the voice coil. If there's no continuity, find the cause as described above.

Otherwise, the voice-coil may be off-center. Reconnect the speaker and then apply light finger pressure around the inside of the speaker cone. If the problem is an off-center voice coil, as you move your fingers around the cone, at some point you should hear a scratching noise. If there's no way to adjust the position of the coil, you'll have to replace the speaker.

### Wrapping up

That's all for speakers and headphones; next time we'll discuss early radio gadgets and trends in cabinet design.

R-E

SEE YOUR DEALER TODAY

FROM

**Firestik®**  
ANTENNAS  
ACCESSORIES

HERE'S A TIP  
THAT'S PERFECT!

AM/FM AUTO RADIO  
AND CB

**Firestik® II**  
GOLDEN SERIES

BARE-HANDS TUNABLE  
"NO TOOLS NEEDED"  
HIGH PERFORMANCE ANTENNAS

ALSO ANTENNAS FOR  
CORDLESS TELEPHONES  
MONITOR SCANNERS

Dealer & Distributor Inquiries Invited  
SEND FOR FREE CATALOG

Firestik® Antenna Company  
2614 East Adams/Phoenix, AZ 85034

Name \_\_\_\_\_  
Street \_\_\_\_\_  
City \_\_\_\_\_  
State \_\_\_\_\_ Zip \_\_\_\_\_

Serving the CB and  
Communications Market Since 1962.

**5-YEAR REPLACEMENT WARRANTY**

CIRCLE 100 ON FREE INFORMATION CARD

**Be an FCC  
LICENSED  
ELECTRONIC TECHNICIAN!**



No costly school. No commuting to class. The Original Home-Study course prepares you for the "FCC Commercial Radiotelephone License". This valuable license is your "ticket" to thousands of exciting jobs in Communications, Radio-TV, Microwave, Computers, Radar, Avionics and more! You don't need a college degree to qualify, but you do need an FCC License.

**No Need to Quit Your Job or Go To School**  
This proven course is easy, fast and low cost! **GUARANTEED PASS** - You get your FCC License or money refunded. **Send for FREE facts now. MAIL COUPON TODAY!**

**COMMAND PRODUCTIONS**

FCC LICENSE TRAINING, Dept. 90  
P.O. Box 2223, San Francisco, CA 94126

Please rush **FREE** details immediately!

NAME \_\_\_\_\_  
ADDRESS \_\_\_\_\_  
CITY \_\_\_\_\_ STATE \_\_\_\_\_ ZIP \_\_\_\_\_

SEPTEMBER 1986

93

## STUNGUN

*continued from page 43*

board is shown in "PC Service;" alternatively, a PC board can be purchased from the source mentioned in the Parts List. If you build the circuit on a per-board, follow our parts layout closely; otherwise you may have problems with arcing.

Due to the critical nature of the three transformers, we are not providing details on winding them. They are available from the source mentioned in the Parts List.

Referring to the parts-placement diagram in Fig. 2, and the photos in Fig. 3 and Fig. 4, mount all components except C2, T1, T2, and T3 on your board. Note that several components mount on the foil side of the PC board: C1, D7, and J1. Do not install those parts yet either.

After all components (except those mentioned above) are installed, check your work very carefully, especially D1-D6, R1, and R3, because T1 will be installed above them, and there will be no chance to correct errors later. After you're absolutely sure that they're installed correctly, install T1 with the black mark on the windings mounted toward C2.

### Foil-side components

One of J1's tabs shares a hole on the PC board with resistor R8, which should be

mounted already. Solder the tab of J1 that corresponds to the tip (not the barrel) of an inserted plug to the indicated pad. Then mount C1 and D7. Last, solder a 1/4-inch piece of 18-gauge wire to the barrel pin of J1, and connect the opposite end of that wire to the appropriate pad beneath S1, the FIRE switch.

### Preliminary check-out

**WARNING: While measuring voltages and currents, keep your face, hands, and all metallic objects away from the high-voltage end of the stun gun. If you want to prod a component, use a non-conductive rod such as a plastic TV alignment tool. High voltage behaves very differently than low voltage. Any material that retains moisture can serve as a discharge path. THAT INCLUDES WOOD! Also, never work on or use the unit when your hands are wet.**

Connect a voltmeter (set to a 1000-volt DC range) to ground and to the output of the D3-D6 diode bridge. Then power up the circuit using either a freshly-charged battery or an external supply capable of delivering 9.8 volts at one amp. If everything is working properly, you should measure about 400-volts DC at the output of the bridge when you press S1.

If you don't measure that voltage, connect an oscilloscope to the collector of Q1 or Q2. You should see a squarewave with a

period of about 100  $\mu$ s. If that waveform is not present, the switching circuit is not operating correctly. *Remove power and check your wiring again. Do not debug the circuit with a battery connected!*

Resistor R6 controls the rate at which the UJT (Q3) discharges, and R3 controls the rate at which C2 charges. You can experiment with the values of those components if you are not satisfied with the circuit's high-voltage output. R3 can vary from 2.2 to 4.7K. You can also experiment with the value of C2. See Table 1.

After the circuit is operating correctly, attach J1 to the board with high-voltage potting compound or RTV. And before you mount the circuit in a case, make sure there's no arcing on the PC board. If there is, you can stop it with a liberal application of RTV, paraffin, or epoxy.

### Conclusion

The stun gun's discharge is very impressive. The spark is highly visible and each discharge produces a sharp, resounding crack. The circuit can teach you much about voltage-multiplying circuits and power supply design. But don't ever forget that the stun gun is not a toy. It can cause much damage to both you and others. Never leave it lying around where children, pets, or anyone unfamiliar with how to use it can handle it. It's a good idea to remove the battery before storing the stun gun. Above all: be careful! **R-E**

## BRAINSTORM

*continued from page 62*

no additional information, as it is indicated in the schematic; instead, it would only clutter up the chassis drawing.

### Circuit board and schematic

Many projects begin with a vague idea for a device followed by some rough circuit sketches. That's OK for the diddle stage, but when its time to generate the schematic, the diagram that will control the building stage of the project, the drawing must be exact and complete.

Once you've finished the schematic, you need to design the circuit-board layout. As you're no doubt aware, when you draw a schematic, the symbols used bear no relationship to the actual size of the components themselves. Thus, while a resistor and capacitor may appear to occupy areas that are roughly equal, in reality the resistor may be only a fraction of the size of the capacitor, especially if the capacitor is a large electrolytic. To be sure that you've allowed sufficient space for each component in your design, use the actual parts and lay them out on an actual-size drawing of the circuit board. That is especially important when design-

ing PC-board layouts. See "Designing Double-Sided Printed Circuit Boards," in the September 1985 issue of **Radio-Electronics** for tips on laying out complicated circuitry. The circuit-board drawing should include identification of the connection points to any off-board components.

### Procedure

You've prepared the paperwork, and you've assembled a kit with all of the parts. Now, you're ready to put the circuit together, turn it on, and watch for smoke. When the building process begins, you switch from designer to technician, with your paperwork guiding you every step of the way.

The following step-by-step procedure applies the paperwork to the construction job, and covers initial assembly to finished product. Steps 1 and 2 cover breadboarding individual circuits for design debugging, and will be repeated until each circuit works on the experimenter's solderless breadboard. Once the circuit operates correctly, final assembly requires repeating steps 1 and 2 to rebuild the circuit in its final form.

**Step 1**—Mount the components on your circuit board (solderless experimenter, perforated, wire wrap, or etched) using the circuit-board drawing as a

guide.

**Step 2**—Do the wiring. When using wire-wrap or point-to-point techniques, as each connection is made, trace over the appropriate line on the schematic using a colored pencil.

For PC boards, the same technique should be followed, but is should be done while you are designing the board. As a trace is laid down, the line or lines on the schematic should be traced over.

Completely test the board using a temporary rig to mount any off-board parts. When the circuit passes all of your tests, it's ready for installation.

**Step 3**—Install the panel-mounted parts.

**Step 4**—Install the circuit board or boards.

**Step 5**—Wire the chassis.

Keep the wiring as short and as neat as possible. Use wiring ties, cable clamps, etc.

**Step 6**—Apply power. If you've been very careful, and followed the steps we've shown you, the odds of getting a correctly working circuit the first time are greatly improved. Of course, they are not.

Fortunately, if you've done your paperwork properly, you will have a paper trail to follow if you run into trouble. Very often that trail will lead you directly to the cause of your problem. **R-E**

# MARKET CENTER

## PLANS AND KITS

**CATALOG:** Hobby/broadcasting/1750 meters/ham/CB: transmitters, amplifiers, antennas, scramblers, bugging devices, more! **PANAXIS**, Box 130-F9, Paradise, CA 95969.

**FREE catalog 99-cent kits—audio, video, TV computer parts. ALLKIT** 434 W. 4th St. West Islip, NY 11795.

**CRYSTAL** radio sets, plans, parts, kits, catalog \$1.00. **MIDCO**, 660 North Dixie Highway, Hollywood, FL 33020.

**HI-FI speaker systems, kits and speaker components** from the world's finest manufacturers. For beginners and audiophiles. Free literature. **A&S SPEAKERS**, Box 7462R Denver, CO 80207, (303)399-8609.

**BUILD** this five digit panel meter and square wave generator including an ohms, capacitance and frequency meter. Detailed instructions \$2.50 refundable plus 50 cents. **BAGNALL ELECTRONICS**, 179 May, Fairfield, CT 06430.

**DESCRAMBLER** plans. New design decodes gated sync suppressed signals—newest pilotless method. Circuit boards, most parts from Radio Shack. Detailed theory, drawings, schematics, instructions \$14.95 plus \$2.00 shipping. **DIRIJO CORP.**, Box 212, Lowell, NC 28098.

**VOICE** disguisers! Telephone bugs! FM bugs! Other kits! Send stamped envelope: **XANDI**, Box 25647, Dept. 60B, Tempe, AZ 85282.

**SAVE money, energy!** Circuit makes batteries last longer! **Use in your own invention!** State of the art. Almost anyone can build. Plans \$10.00. **WAYNE KESSLER**, Box 685, Plymouth Meeting, PA 19462.

**NEW! Fiber Optic** voice link. Send your voice over a beam of light via an optical fiber. Complete kit includes microphone, speaker, fiber, PCB's and all parts. Easily assembled. Introductory offer—send \$34.95 to: **FIBER SCIENCES, KIT-73A**, PO Box 5355, Chatsworth, CA 91313-5355. CA residents add 6.5%.

**EPROM, Eeprom** zapper kit. Stand alone, RS232, parallel. \$5. plans, \$99. kit, free literature. **MICRO KIT**, 6910 Patterson, Caledonia, MI 49316 (616) 791-9333

**STEREO TV adapter kit.** Easily converts any TV/VCR to receive the new stereo TV sound. Contains all part PCB and instructions to build a quality stereo decoder. For additional information send SASE to **SOKOLOWSKI**, Box 150, Elmont, NY 11003.

**MASTERCARD AND VISA** are now accepted for payment of your advertising. Simply complete the form on the first page of the Market Center and we will bill.

**CABLE and Subscription TV** secret manual. Build your own descramblers, converters. Instructions, schematics for: Sinewave, Inband/Outband Gated Sync Pulse, SSAVI—(HBO, Showtime, Cinemax) **CABLETRONICS**, Box 30502R, Bethesda, MD 20814.

**DESCRAMBLE** the latest video cassette copy protection scheme. Our simple circuit takes the jitter out of your picture. Complete plans and theory only \$6.95. **ELEPHANT ELECTRONICS INC.** Box 41865-J, Phoenix, AZ 85080 (602) 581-1973.

**CABLE TV Converters: Jerrold Products** include "New Jerrold Tri-Mode", SB-3, Hamlin, Oak VN-12, M-35-B, Zenith, Magnavox, Scientific Atlanta, and more. (Quantity discounts) 60 day warranty. Service converters sold here. For fast service C.O.D. orders accepted. Send SASE (60 cents postage) or call for info (312) 637-4408. **HIGGINS ELECTRONICS**, 5143-R W. Diversey, Chicago, IL 60639. No Illinois orders accepted.

**PROJECTION TV...** Convert your TV to project 7 foot picture. Results comparable to \$2,500. projectors. Total cost less than \$30. Plans and 8" lens \$21.95. Illustrated information free. **MACROCOMA-GA**, Washington Crossing, PA 18977. Credit card orders 24 hours (215) 736-3979.

**TEST** Transistors Diodes Capacitors, Resistors unique scope adapter, for plans send \$5 money order to **GNS ELECTRONICS**, 1110 Magnolia, Oxford, CA 93030.

## CLASSIFIED AD ORDER FORM

To run your own classified ad, put one word on each of the lines below and send this form along with your check to:

**Radio-Electronics Classified Ads**, 500-B Bi-County Boulevard, Farmingdale, NY 11735

**PLEASE INDICATE** in which category of classified advertising you wish your ad to appear. For special headings, there is a surcharge of **\$23.00**.

( ) Plans/Kits ( ) Business Opportunities ( ) For Sale  
( ) Education/Instruction ( ) Wanted ( ) Satellite Television  
( ) \_\_\_\_\_

Special Category: \$23.00

### PLEASE PRINT EACH WORD SEPARATELY, IN BLOCK LETTERS.

(No refunds or credits for typesetting errors can be made unless you clearly print or type your copy.) Rates indicated are for standard style classified ads only. See below for additional charges for special ads. **Minimum: 15 words.**

1	2	3	4	5
6	7	8	9	10
11	12	13	14	15 (\$42.75)
16 (\$45.60)	17 (\$48.45)	18 (\$51.30)	19 (\$54.15)	20 (\$57.00)
21 (\$59.85)	22 (\$62.70)	23 (\$65.55)	24 (\$68.40)	25 (\$71.25)
26 (\$74.10)	27 (\$76.95)	28 (\$79.80)	29 (\$82.65)	30 (\$85.50)
31 (\$88.35)	32 (\$91.10)	33 (\$94.05)	34 (\$96.90)	35 (\$99.75)

We accept MasterCard and Visa for payment of orders. If you wish to use your credit card to pay for your ad fill in the following additional information (Sorry, no telephone orders can be accepted.):

Card Number \_\_\_\_\_ Expiration Date \_\_\_\_\_

Please Print Name \_\_\_\_\_

Signature \_\_\_\_\_

**IF YOU USE A BOX NUMBER YOU MUST INCLUDE YOUR PERMANENT ADDRESS AND PHONE NUMBER FOR OUR FILES. ADS SUBMITTED WITHOUT THIS INFORMATION WILL NOT BE ACCEPTED.**

**CLASSIFIED COMMERCIAL RATE:** (for firms or individuals offering commercial products or services) \$2.85 per word prepaid (no charge for zip code)...**MINIMUM 15 WORDS.** 5% discount for same ad in 6 issues; 10% discount for same ad in 12 issues within one year; if prepaid. **NON-COMMERCIAL RATE:** (for individuals who want to buy or sell a personal item) \$2.30 per word, prepaid...no minimum. **ONLY FIRST WORD AND NAME** set in bold caps at no extra charge. Additional bold face (not available as all caps) **50¢ per word additional (20% premium).** Entire ad in boldface, add **20% premium** to total price. **TINT SCREEN BEHIND ENTIRE AD:** add **25% premium** to total price. **TINT SCREEN BEHIND ENTIRE AD PLUS ALL BOLD FACE AD:** add **45% premium** to total price. **EXPANDED TYPE AD:** \$4.30 per word prepaid. All other items same as for STANDARD COMMERCIAL RATE. **TINT SCREEN BEHIND ENTIRE EXPANDED TYPE AD:** add **25% premium** to total price. **TINT SCREEN BEHIND ENTIRE EXPANDED TYPE AD PLUS ALL BOLD FACE AD:** add **45% premium** to total price. **DISPLAY ADS:** 1" x 2 1/4"—\$310.00; 2" x 2 1/4"—\$620.00; 3" x 2 1/4"—\$930.00. **General Information:** Frequency rates and prepayment discounts are available. **ALL COPY SUBJECT TO PUBLISHERS APPROVAL. ADVERTISEMENTS USING P.O. BOX ADDRESS WILL NOT BE ACCEPTED UNTIL ADVERTISER SUPPLIES PUBLISHER WITH PERMANENT ADDRESS AND PHONE NUMBER.** Copy to be in our hands on the 12th of the third month preceding the date of the issue. (i.e., August issue copy must be received by May 12th). When normal closing date falls on Saturday, Sunday or Holiday, issue closes on preceding working day.

## BUY BONDS

THE BEST PLACE TO BUY, SELL or TRADE NEW and USED EQUIPMENT

**NUTS & VOLTS MAGAZINE**  
 BOX 1111-E • PLACENTIA, CA 92670  
 (714) 632-7721

Join Thousands of Readers Nationwide  
 Every Month

**ONE YEAR U.S. SUBSCRIPTIONS**  
 \$10.00 - 3rd Class • \$15.00 - 1st Class

**Foreign** \$35.00 - Lifetime - 3rd Class

**NUTS & VOLTS**  
 MONTHLY

HIGH CLEAR  
 COMPUTERS  
 SOFTWARE  
 SCANNERS • OPTICS  
 TEST EQUIPMENT  
 MICROWAVE  
 SATELLITE  
 AUDIO VISUAL  
 NEW PRODUCTS  
 COMPONENTS • KITS  
 ANTIQUE ELECT.  
 PUBLICATIONS  
 PLANS • SERVICES

**6032** infrared tubes (tested and guaranteed), infrared kits, complete line of engineering and surveillance viewers. **IR SCIENTIFIC, INC.**, Box 110, Carlisle, MA 01741 (617) 667-7110.

**JERROLD** gated pulse theory. Twelve information packed pages covering DI and DIC converter operation. Includes introduction to trimode system. \$6.95. **ELEPHANT ELECTRONICS, INC.**, Box 41865-J, Phoenix, AZ 85080 (602) 581-1973

**SATELLITE descrambling** Latest method—including digital audio descrambling. \$10.95. Design manual for constructing **parabolic satellite dish antennas**. \$9.95 **CABLETRONICS**, Box 30502RE, Bethesda, MD 20814.

**FM Transmitter Kit**, matchbox size, super sound sensitivity, board, parts, easy educational instructions, \$19.95. **PTS**, Box 1951, Fort Worth, TX 76101.

**PHONE** tap into automatic on/off control for cassette recording phone conversations \$3.95. **BLED-SOE**, 135 Cupp Dr, Central Point, OR 97502.

**DESCRAMBLER** Plans \$4.95 constructed easily thousands in use. **CAREER ENTERPRISES**, PO Box 3263, Bridgeport, CT 06605 0263.

**CIRCUIT boards**, Kits, and Assemblies for QST Articles. For info SASE to: **A&A Engineering**, 7970 Orchid Dr. Buena Park, CA 90620. (714) 521 4160.

## CB MODIFICATIONS

Increase channels, range, privacy! We specialize in frequency expanders, speech processors, FM converters, PLL & slider tricks, how-to books, plans, kits. Expert mail-in repairs & conversions. 16-page catalog \$2. Our 11th year!  
**CBC INTERNATIONAL, P.O. BOX 31500RE.**  
**PHOENIX, AZ 85046**

## EDUCATION & INSTRUCTION

**F.C.C. Commercial General Radiotelephone License**. Electronics home study. Fast, inexpensive! "Free" details. **COMMAND**, D-176, Box 2223, San Francisco, CA 94126.

## COMPREHENSIVE EVALUATION and ADVISORY SERVICE



A NON PROFIT ORGANIZATION

For professional electronic technicians by prestigious **NON-PROFIT** organization. Earn University Degree (Bachelors or Masters) through Home Study! Credit given for previous schooling and professional experience. Upgrade your status and life-style.

**CONTINENTAL EDUCATION ASSOCIATES**  
 P.O. Box 1197 • Champlain, NY 12919-1197

**COMPUTER** repair career training in 5 months by accredited Florida electronics school. Lifetime placement. Financial assistance if qualified. Call **SYSTEMS TECHNOLOGY INSTITUTE**. (305)331-2840.

**SPEECH** synthesis manual. Build projects that talk back. For everything you need to know about creating human like speech and robot talk, send \$12.95 to: **J&J ENTERPRISES**, 3510 North 72nd Street, Omaha, NE 68134.

## Get into Telecommunications Installation and Repair

Learn at home in spare time. Telecommunications repairers work on telephone, telegraph, computer networks! Home-study course shows you what to do, how to do it! Books, manuals, tool kit included with course. Be ready for money making job in just a few months. Send for **FREE FACTS' School of Telecommunications**  
 925 Oak St., Dept. DE086, Scranton, PA 18508. #3204

## SATELLITE TV

**CABLE TV Secrets**—the outlaw publication the cable companies tried to ban. HBO, Movie Channel, Showtime, descramblers, converters, etc. Suppliers list included \$8.95. **CABLE FACTS**, Box 711-R, Pataskala, Ohio 43062.

**CABLE TV Source Book**—a complete listing of suppliers for hard-to-find converters, descramblers, technical information, schematics and much more. Full refund if not satisfied. Send \$4.95 to **CABLE**, Box 12505-R, Columbus, OH 43212.

**SATELLITE Descrambler Schematics**: Oak Orion PD-400C \$20.00; VideoCipherII \$20.00 VideoCipherII Patent \$15.00; actual VideoCipherII descrambler \$550.00; actual Oak Sigma descrambler \$350; Catalog \$5.00; send money order to **ELECTRONIC PRESS**, PO Box 10009, Colorado Springs, CO 80932.

**PATENTED** optical process satellite sound system. For information send \$3.00 to: **BEDINI ELECTRONICS**, PO Box 769, San Fernando, CA 91341.

### Pay TV and Satellite Descrambling All New 6th Edition!

Now over 100 pages of working schematics, theory and "hard" information on all the major cable and over the air scrambling systems. Schematics and theory for all 4 satellite descrambling systems used currently, HBO, Anik-D, Fantasy, Extasy etc. New sections on digital audio coding and bypassing. Insider information included. Still the most complete source of descrambling info available \$14.95. Satellite Systems Under \$600, \$11.95. MDS Handbook \$10. Stun gun schematics \$5. Enlarged product catalog of PC's, kits and low cost satellite equipment \$2.

**Shojiki Electronics Corp., 1327R**  
**Niagara St., Niagara Falls, NY**  
**14303. COD's 716-284-2163**

59 degree brand name LNA's! LNB's! Ku-Band LNB's! Discount pricing! Send stamped envelope: **LNA**, 201 E Southern, Suite 100F, Tempe, AZ 85282.

**SATELLITE** systems \$349.00, catalog \$3.00. Also: KU; Exports; descramblers **STARLINK, INC.**, 2603-16R Artie, Huntsville, AL 35805.

"**TRIPLE-X**" Satellite TV Descrambler (**Non Addressable**). XXX Adult Movies, Fully Assembled. \$225. **NAS-SAT**, Box 5261, Long Beach, CA 90805, (213)631-3552.

**DISCOUNT CATV** Converters/Decoders and video accessories. Free information. **EASY VIEW**, PO Box 221B, Arlington Heights, IL 60006 (312) 952 8504 ask for Rudy Valentine.

**FEELING Scrambled?** Here's the answer! **Micro-wave TV receivers** 20" dish system (1.9 2.7GHz). Lifetime warranty. Send \$89.95 to: **K&S ELECTRONICS**, Box 34522RE, Phoenix, AZ 85067. \$2. credit on phone orders (602) 230 0640. Call now for same day shipping! Dealer rates/brochure SASE VISA MC/COD'S

**SECRET** "Hidden Signals" on satellite TV are easily decoded. New 179 page book covers theory and describes equipment needed. \$19.95 plus \$2 P&H. **ELEPHANT ELECTRONICS, INC.**, Box 41865-J, Phoenix, AZ 85080 (602) 581 1973.

**SATELLITE owners unlock your videocipher descrambler, parts and plans** \$35.00 I (305) 752 9202.

**BUILD** your own satellite system and save! Instructions, schematics, parts! Send stamped envelope: **XANDI**, Box 25647, Dept. 21E, Tempe, AZ 85282.

## WANTED

**INVENTORS!** AIM wants—ideas, inventions, new products, improvements on existing products. We present ideas to manufacturers. Confidentiality guaranteed. Call toll free (1-800)225-5800 for information kit.

**INVENTIONS**, ideas, new products wanted! Industry presentation/national exposition. Call free (1-800)528-6050. Canada, 1-800-528-6060. X831.

**TURNTABLE**, transcription, 16 inch. **BLACKARD**, Route 2, Box 222, Trinity, AL 35673

**SOLVE** new software protection code: earn \$9,000. immediately! Sample \$1.00. **CODE RESEARCH**, Box 841, Cornelius, OR 97113

## BUSINESS OPPORTUNITIES

**MECHANICALLY** inclined individuals desiring ownership of small electronics manufacturing business—without investment. Write: **BUSINESSES**, 92-R, Brighton 11th, Brooklyn, NY 11235.

**YOUR own radio station!** AM, FM, TV, Cable. Licensed/unlicensed. **BROADCASTING**, Box 130-F9 Paradise, CA 95969.

**EASY**, one man, hi-profit C.R.T rebuilding equipment. **C.R.T.**, 1909 Louise, Crystalake, IL. 60014 (815) 459-0666.

**PROJECTION TV** . . . Make \$\$\$'s assembling projectors . . . easy . . . results comparable to \$2,500 projectors . . . Your total cost less than \$30.00 . . . plans, 8" lens and dealers information \$20.50 . . . illustrated information free . . . **MACROCOMAGAX**, Washington Crossing, Pennsylvania 18977. Creditcard orders 24 hours (215) 736-2880.

**YOUR** electronics knowledge means honest part time income. Write **YOUR MARKETING**, 479 Cherokee Ridge, Athens, GA 30606.

**BIG PROFITS**

## ELECTRONIC ASSEMBLY BUSINESS

Start home spare time. Investment knowledge or experience unnecessary. **BIG DEMAND** assembling electronic devices. Sales handled by professionals. Unusual business opportunity

**FREE: Complete illustrated literature**  
 BARTA, RE-O Box 248  
 Walnut Creek, Calif. 94597

## FOR SALE

**TUBES** new, unused. Send self-addressed, stamped envelope for list. **FALA ELECTRONICS**, Box 1376-2, Milwaukee, WI 53201.

**LINEAR parts, tubes, transistors** —MRF454 \$16, MRF455 \$12, MRF477 \$11, MRF492 \$18. Catalog. **RFCP**, Box 700, San Marcos, CA 92069 (619)744-0728.

**RESTRICTED technical information:** Electronic surveillance, schematics, locksmithing, covert sciences, hacking, etc. **Huge selection. Free brochure.** **MENTOR-Z**, 135-53 No. Blvd., Flushing, NY 11354.

**OLDTIME** radio programs on high quality tapes. Comedy! Adventure! Music! Free catalog. **CARL F. FROELICH**, Heritage Farm, New Freedom, PA 17349.

**TV** tunable notch filters, free brochure. **D.K. VIDEO**, Box 63/6025, Margate, FL 33063 (305)752-9202.

**TEST** equipment, reconditioned. For sale. \$1.25 for catalog. **WALTER'S**, 2697 Nickel, San Pablo, CA 94806 (415)724-0587.

**LASERS** and nightvision surplus components. Free catalog. **M.J. NEAL COMPANY**, 6672 Mallard Ct., Orient, OH 43146.

**TI-99/4A** software/hardware bargains. Hard to find items. Huge selection. Fast service. Free catalog. **DYNA**, Box 690, Hicksville, NY 11801.

**FREE Adapter** (limited offer) with **Assortment #103**-consisting of **Toko Coils** 144LY-120K, 520 HN-3000023, BKAN-K555AXX (2); **PCB; Transistors** 2N3904 (2), BFQ85 (sub); **IC's** 7812, 74123, MC1330A1P; **Diodes** 1N914, 1N5231B. Only \$25.00 10% discount for 5 or more. Shipping. \$3.00/order **MC/Visa/COD**. Toll free 1-800-821-5226 Ext. 426 (orders). **Jim Rhodes, Inc.**, 1025 Ransome Lane, Kingsport, TN 37660.

**TUBES**, name brands, new, 80% off list. **KIRBY**, 298 West Carmel Drive, Carmel, IN 46032.





## BURGLAR ALARM

*continued from page 44*

Begin by drilling holes for the two LED's and the key switch; also drill two mounting holes. Be careful, as a neat, "professional" looking job will help enhance the effect. Next, secure a "C"-cell battery holder to the panel using RTV adhesive; the holder should be located just below the holes for the LED's. Then mount the key switch in the appropriate hole. Wire the switch and the battery holder to the appropriate points on the board, keeping lead lengths as short as possible. Bend the LED's 90° so that they are parallel with the board. Position the LED's in the holes you previously drilled for that purpose so that they protrude about 1/8 inch. Finish up by securing the board to the top of the battery holder with a piece of double sided tape. Fig. 3 shows how it should look.

The unit can be installed just about anywhere. We suggest mounting it in your door frame for a professional look.

Although the circuit doesn't actually do anything, you should make it a habit to "arm" and "disarm" it as appropriate. That little bit of theater will help convince a burglar who is "casing" your home that it is indeed protected as advertised. **R-E**

## AMAZING DEVICES

PHASORS

**PLANS**—All Parts Available in Stock

- LC5 BURNING CUTTIG CO2 LASER ... \$20.00
- RUB3 RUBY LASER RAY PISTOL ... 20.00
- BTC5 1.5 MILLION VOLT TESLA COIL ... 15.00
- PTG1 PLASMA TORNADO GENERATOR 10.00
- GRA1—GRAVITY GENERATOR ... 10.00
- MAGNETIC CANNON PROJECTOR ... 10.00

LASERS

**KITS**—Includes Plans and Parts

- LHC2K SIMULATED RED/GRN/YEL LIGHT LASER ... 34.50
- BTC3K 250,000 VOLT TESLA COIL ... 159.50
- 10G1K ION RAY GUN ... 109.50
- PSP3K PHASOR SHOCK WAVE PISTOL 49.50
- STG1K—STUN/PARALYZING GUN ... 39.50
- INF1K INFINITY TRANSMITTER ... 134.50
- MFT1K 2-3 MILE RANGE FM VOICE XMTR PC BOARD ... 49.50

SECURITY

**ASSEMBLED AND TESTED PRODUCTS**

- LGU30 RED 1MW PORTABLE HENE LASER ... 349.50
- TCL30 SOLID STATE TESLA COIL 35KV 84.50
- IPG50 POCKET PAIN FIELD GENERATOR 64.50
- BLS10 BLASTER DEFENSE WEAPON ... 89.50
- ITM10—100KV SHOCK AND STUN GUN 99.50
- PPF10 PHASOR PAIN FIELD PORTABLE 249.50
- SNP20 SECURITY PHONE LISTENER ... 99.50

● CATALOG CONTAINING DESCRIPTIONS OF ABOVE PLUS HUNDREDS MORE AVAILABLE FOR \$1.00 OR INCLUDED FREE WITH ALL ABOVE ORDERS.

PLEASE INCLUDE \$3.00 PH ON ALL KITS AND PRODUCTS. PLANS ARE POSTAGE PAID. SEND CHECK. MO. VISA, MC TO:

**INFORMATION UNLIMITED**

P.O. BOX 716, DEPT. N1 AMHERST, NH 03031

**SCIENTIFIC Atlanta** cable equipment! We have 8550's 8500's complete cable boxes. See all the channels! All units are just waiting for you. Descramblers and Remotes. **ADVANCED TECHNOLOGY SYSTEMS**, Box 316, Auburn, MA 01501, (617)832-2339.

**SPECTACULAR** strobe light chasers, stroboscopic devices, Helium-Neon Laser components, scientific items, more! Free catalog. **ALLEGRO ELECTRONIC SYSTEMS**, #3R Mine Mountain, Cornwall Bridge, CT 06754.

**CHIP** Checker tests/identifies: 54/74 TTL, 4000 CMOS, 54/74 CMOS. Two 24 pin ZIF sockets handle .3" and .6" wide chips. For C128 and C64. \$129 plus \$3.50 s&h. **DUNE SYSTEMS**, 2603 Willa Dr., St. Joseph, MI 49085, (616)983-2352.

**TUBES** "oldest," "latest". Parts, components, schematics. SASE for list. **STEINMETZ**, 7519 Maplewood Ave., R.E., Hammond, IN., 46324.

**ELECTRONICS**. \$1.50 brings flyer, grab bag. **LYNN JOHNSON**, 2221 The Alameda #176, Santa Clara, CA 95050.

**BATTERIES** NiCad, sealed lead acid, and more from national brands such as Panasonic, Eagle-Picher, and others. Write or call for listing. **DC Power, Inc.**, 1213 Old Colony Rd., Wallingford, CT 06492, (203)237-2292.

**ANTIQUE** radio hobbyists—20 page catalog of tubes, parts, and literature for radio restoration. Send \$2.00 to **ANTIQUE ELECTRONIC SUPPLY**, 688 W. First St., Tempe, AZ 85281

**CABLE-TV** converters and equipment. Plans and parts. Build or buy. Free information. **C&D ELECTRONICS**, PO Box 1402, Dept. RE, Hope, AR 71801.

**35 - 70% saving**—bargain catalog for 39 cents stamp. **APEX ELECTRONICS MOD**, 8909 San Fernando, Sun Valley, CA 91352.

**TURBO circuit analysis** Generates matrix equations for AC, DC and Transient Analysis. Source code for Worst Case, Plots. Requires MS-DOS and Turbo Pascal or FORTRAN. VISA/MC. \$149. **CLIFFORD VANDER YACHT**, Computer Consultant, 3778 Hitching Post Road, Jackson, MI 49201, (517)782-2297.

**HIGH gain descramblers**, CRT automatic dimmer, SCR Tester, plus other unusual electronic devices. Send \$3 for info. **RB ELECTRONICS ENGINEERING**, PO Box 643 Kalamazoo, MI. 49005.

**PING-Pong** 8/section light chaser controller \$34.95. Strobe light \$9.95. (Perfect disco setup). Vehicle alarm-current sensor \$14.95. **ADVANCED CONCEPTS**, 38575 9th St. East, Suite 264, Palmdale, CA 93550 (805) 273 6449

IS it true...Jeeps for \$44. through the Government? Call for facts! 1-312-742-1142 Ext. 4673.

**CABLE TV** converters manual and wireless Jerrold DRZ DRX Philips volume converters. **REDCOAT ELECTRONICS**, PO Box 504, Jamaica, NY 11475. (718) 459-5088.

**SCIENTIFIC Atlanta** stand alone—8500 series (Original Units), remote control. Fully guaranteed \$250. N.A.S., (213) 631 3552.

**VIDEO** scrambling techniques, the original "secret manual" covers sinewave, gatedpulse, and SSAVI systems. 56 pages of solid, useful, legible information, only \$14.95. **ELEPHANT ELECTRONICS INC.**, Box 41865-J, Phoenix, AZ 85080 (602) 581 1973.

**ELECTROCALC** can do your electronics calculations: Crossover, resonance etc. For Commodore C-64 or 128 (specify). \$19.95 post paid. **NOVA-SOFT**, Route 1, Box 107B, Kinston, NC 28501.

**MODEL PS-320** Triple Supply. 5V, 1.5A, ±15V, 0.7A. 8" x 6" x 3" detachable power cord. Contact **RCB ENGINEERING PRODUCTS**, Box 143, Hanover, MD 21076 (301) 796 3099.

**UNIDEN** Exports radio and amps send \$5. **WASHINGTON ENTP.**, 1725 North Bond Street, Balto., MD 21213.

**ONE** picture tube rebuilding machine. One man operation. Buyer must pick up in El Paso. \$5500. **ADAMSON** 3204 Stone Edge, El Paso, TX 79904 (915) 755 8942.

**ELECTROLYTICS**: 48,000µF 40V. Sprague's best computer "Extralytic". New w/specs. \$4.95 2/\$7.50. **WALZ**. 3327 Allendorf, Pittsburgh, PA 15204.

**SURPLUS** military/commercial Test and communications equipment—1986 catalog. Send \$1. **MIL-COM EXCHANGE ELECTRONICS**, Box 982-RE, Orange Park, FL 32067-0982.

**CLONE** kits, modems, hard drive kits, disk drives, diskettes and printers, memory, and IC's. Distributor pricing to end users and dealers. For catalog call 1-800-833-2600. In Ohio call 513-531-8866. Free shipping.

**FREE** electronics parts. All sorts, for inventors, designers, experimentors. How and where to get them. No exaggeration. Send single fee \$6.95 to **AMERICAN TRANS-GLOBAL**, Box 7033, Huntington, WV 25775.

## REEL-TO-REEL TAPES

**AMPEX** professional series open reel tape. 1800-or 2400-feet on 7-inch reels. Used once. Case of 40. \$45.00. 10 1/2 x 3600 feet and cassettes available. MasterCard, Visa. **VALTECH ELECTRONICS**, Box 6-RE, Richboro, PA 18954. (215) 322-4866.

## DO IT YOURSELF REPAIR

**NEW...repair any TV...easy** Anyone can do it. Write, **RESEARCH**, R13 Box 601BR Colville, WA 99114.

## PRINTED-CIRCUIT BOARDS

PCB 15 cents sq-in. free drilling. Quantity discounts. Professional work. **INTERNATIONAL ENTERPRISE**, 6452 Hazelcirdle, Simivalley, CA 93063.

## INVENTORS

**INVENTORS!** Can you patent and profit from your idea? Call **AMERICAN INVENTORS CORPORATION** for free information. Over a decade of service. (1-800)338-5656. In Massachusetts or Canada call (413) 568-3753.

## PRINTED-CIRCUIT BOARDS

**FAST** service. Guaranteed lowest quotes. Average \$0.12 / inch (FR-4), Single sided / multilayered boards. Plated thru holes. Any quantity. Send specifications/call for quotes and details. **CATALOG** of electronics components and projects—send SASE—**T.O.R.C.C.C.**, Box 47148, Chicago, 60647, (312)-342-9171.

**PRINTED**-circuit boards and artwork design cad/cam plated through holes. Competitive pricing. **EXPRESS CIRCUITS**, 314 Cothren Street, PO Box 58, Wilkesboro, NC 28697 (919) 667-2100.

## CABLE-TV

**DEALERS** wanted: channel 2,3, and 4 notch filters. Money back guarantee. Send \$15.00 for sample and quantity price list. Specify channel(s). **GARY KURTZ**, Box 291394, Davie, FL 33329.

## SPEAKER REPAIR

**SPEAKER** reconing—radio, hi-fi, musical instrument. All work guaranteed. **SSI** 1925 Chartwell, Ft. Wayne, IN 46816 219-42-MUSIC.

**THIS IS A BOLDFACE EXPANDED AD.** If you like this format, request it. Your cost is \$3.75 per word, plus 45% for the boldface and tint background.



WRITE FOR  
**McGEE'S**  
SPEAKER & ELECTRONICS CATALOG

1001 BARGAINS IN SPEAKERS  
toll free 1-800-346-2433 for ordering only.  
1901 MCGEE STREET KANSAS CITY, MO. 64108

# Radio Shack Parts Place™

'87 CATALOG AVAILABLE—COME GET YOUR FREE COPY!

184 Full-Color Pages ■ Hundreds of New Items and New Low Prices ■ Not Sent by Mail

## (1) Breadboard It

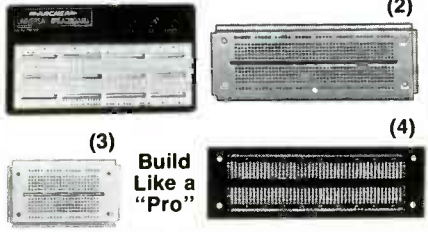

- (1) **Universal.** Our best! Breadboard is mounted on a 7 x 4" "stay-put" steel base with rubber feet. 640 plug-in points, 3 binding points. #276-169, 19.95
- (2) **Modular Breadboard Socket.** 2 buses, 550 indexed connection points. Snap together for more complex designs. 2 1/8 x 6". #276-174 ..... 11.95
- (3) **Modular Breadboard Socket.** Smaller version of Fig. 2. 2 1/8 x 3 5/8". #276-175 ..... 6.95
- (4) **Matching PC Board.** Same layout as sockets for easy circuit transfer. #276-170 ..... 2.69

## Books by Forrest Mims

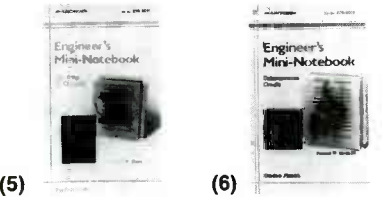

- Easy-to-Read Schematics
- Parts in Stock at Radio Shack
- (5) **Op Amp Mini-Notebook.** Learn as you build! 48 pages contain over 40 clever circuits using popular op amps such as the 741. #276-5011 ..... 1.49
- (6) **Optoelectronics Mini-Notebook.** 48 pages. Features a great introductory section on optical components. Projects range from a simple LED circuit to lightwave transmitter/receiver circuits. #276-5012 ..... 1.49

## Voice Synthesizer Team

### Add Voice to Your Computer



- (7) **SPO256-AL2 Speech Synthesizer IC.** MOS/LSI device is easy to interface with most computers. With data. 28-pin DIP. #276-1784 ..... 12.95
- (8) **CTS256-AL2 Text-to-Speech IC.** Translates ASCII characters into control data for Fig. 7. With data. 40-pin DIP. #276-1786 ..... 16.95

## Fiber-Optics Components

- (9) **Optical Fiber Cable.** 3-meter length of high-quality optical cable is ideal for experiments. #276-228 ..... 5.99
- (10) **Emitter/Detector Set.** Use to send analog or digital signals through fiber optic cable. With data. #276-225 ..... 4.99

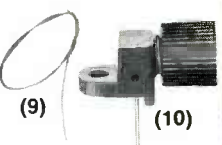

## Easy-to-Use Soundmakers



- (11) **Electronic Chime.** IC/speaker combo produces a "ding-dong" sound. 12 VDC. #273-071 ..... 6.95
- (12) **2-Tone Piezo Buzzer.** Really gets attention! Operates 8 to 16 VDC. #273-070 ..... 8.95
- (13) **PC-Mount Piezo Buzzer.** Loud, yet consumes only 12 milliamperes at 12 VDC. #273-065 ..... 2.49

## Hi-Q Ceramic Discs



pF	VDC	Cat. No.	2-Pack	pF	VDC	Cat. No.	2-Pack
4.7	50	272-120	39	.001	500	272-126	49
47	50	272-121	39	.0047	500	272-130	49
100	50	272-123	39	.01	500	272-131	49
220	50	272-124	39	.047	50	272-134	49
470	50	272-125	39	1	50	272-135	49

## Battery Guidebook

### Helps You Select The Right Battery

Learn how batteries work, how to recharge and test them, and how to choose the best values. Includes complete technical data on all ENERGEL® batteries. 160 pages. #62-1396 ..... 1.99

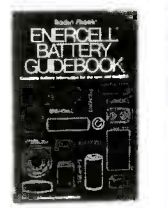

## Resistor Kit Bargains



- (14) **1/4-Watt.** 5% tolerance. 100-piece set includes 13 popular standard values ranging from 10 ohms to one megohm. #271-308 ..... 2.79
- (15) **Precision Metal-Film.** 1/4-watt, 1% tolerance. 50 piece set includes 12 popular standard values ranging from 10 ohms to one megohm. #271-309 ..... 2.49

## Tantalum Capacitors

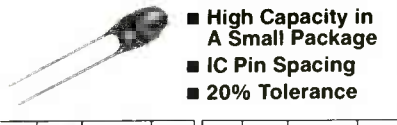

■ High Capacity in A Small Package  
■ IC Pin Spacing  
■ 20% Tolerance

µF	VWDC	Cat. No.	Each	µF	VWDC	Cat. No.	Each
0.1	35	272-1432	49	2.2	35	272-1435	59
0.47	35	272-1433	49	10	16	272-1436	69
1.0	35	272-1434	49	22	16	272-1437	89

## Low-Cost Panel Switches



- (16) **Submini Toggle.** 3 A at 125 VAC. 1/4" mtg. hole. SPST. 275-612 ..... 1.69 SPDT. 275-613 ..... 1.79 DPDT. 275-614 ..... 2.19 DPDT Center-Off. 275-620 ..... 2.29
- (17) **Submini SPST Momentary.** Rated 0.5 amp at 125 VAC. Normally open. 1 1/2 x 1/4". Includes one red, one black. 3/8" mtg. hole. 275-1571 ..... Set of 2/1.69

## Hobby Motor Bargains



- (18) **High Torque.** 8300 maximum RPM, operates 1.5 to 3VDC. Approximately 1 1/2" long by 1 5/16" dia. #273-223 ..... 79¢
- (19) **With Brass Pulley.** Built-in noise filter. Operates 3 1/2 to 9 VDC. #273-229 ..... Pkg. of 2/1.49

## Digital Logic Probe



**NEW!**

The fast way to test TTL, LS and CMOS digital circuits. Color-coded LEDs indicate high, low or pulsed logic states (up to 10 MHz). Simultaneous tone output frees your eyes for faster testing. 36" leads with clips provide power from circuit under test. With instructions. #22-303 ..... 16.95

## 21-Range Digital VOM

Cut 37%  
**SUPER SAVER!** Reg. 59.95 **3788**

Accuracy, ease of use and famous Microtonta® quality at 33% off! Features big LCD display, "beep" continuity test mode, ohms zero-adjust button, diode-check mode. Measures to 1000 volts DC, 500 volts AC. AC/DC current to 200 mA. Resistance to 20 megohms. 6 3/8 x 3 1/2 x 1 3/8". With owner's manual and probes. Requires 2 "AA" batteries. #22-191, Sale 37.88

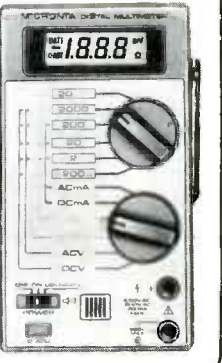

## Attention-Getting LEDs



- (20) **Super-Bright Red LED.** A real breakthrough! Outputs 300 mcd at 20 mA yet runs cool. Point-source type in a clear epoxy T-1 3/4 package. #276-066 ..... 99¢
- (21) **CQX21 Blinking LED.** Combines MOS driver IC and red LED in a T-1 3/4 package. #276-036, 1.19

## Digital Logic Pulser



**NEW!**

Together, the pulser and probe make an effective diagnostic team for testing today's digital circuits. Produces single 5 µs pulse or a continuous 5 Hz pulse train at the push of a button. Features overload protection and low output impedance. With instructions. #22-304 ..... 17.95

Over 1000 items in stock: Binding posts, Books, Breadboards, Buzzers, Capacitors, Chokes, Clips, Coax, Connectors, Fuses, Hardware, ICs, Jacks, Knobs, Lamps, Multitesters, PC Boards, Plugs, Rectifiers, Relays, Resistors, Switches, Tools, Transformers, Transistors, Wire, Zeners, more!

**Radio Shack®**  
A DIVISION OF TANDY CORPORATION  
Prices apply at participating Radio Shack stores and dealers



# Worldwide • Since 1974

• QUALITY COMPONENTS • COMPETITIVE PRICING  
• PROMPT DELIVERY

Mail Order Electronics • Worldwide  
**Jameco**  
ELECTRONICS

## COMMODORE® COMPATIBLE ACCESSORIES

**Now Compatible With C-128!**

**RS232 Adapter for VIC-20, C-64 and C-128**

The JE232CM allows connection of standard serial RS232 printers, modems, etc. to your VIC-20, C-64 (excluding the SX-64 Portable), and C-128. A 4-pole switch allows the inversion of the 4 control lines. Complete installation and operation instructions included.

• Plugs into User Port • Provides Standard RS232 signal levels  
• Uses 6 signals (Transmit, Receive, Clear to Send, Request to Send, Data Terminal Ready, Data Set Ready)

**JE232CM . . . . . \$39.95**

**Voice Synthesizer VIC-20 & C-64**  
Plug-in - Talking in Minutes!

**JE520CM . . . . . \$99.95**

**300 Baud Auto Modem**  
Mitey-Mo (For C-64) . . . . . \$54.95

**Parallel Printer Interface**  
2K Buffer, Expandable to 10K!  
MW350 (For VIC-20, C-64 & C-128) . . . . . \$54.95

## TRS-80® COMPATIBLE ACCESSORIES

**E-X-P-A-N-D TRS-80 MEMORY**

All kits come complete with documentation

**TRS-80 MODEL I, III**

TRS-16K3 200ns (Model III) . . . . . \$5.95  
TRS-16K4 250ns (Model I) . . . . . \$5.49

**TRS-80 COLOR AND COLOR II**  
TRS-64K-2 . . . . . \$11.95

New models only -

TRS-CoCo-Incl. 2-50464's (41464's) . . . \$13.49

**TRS-80 MODEL 4, 4P**

TRS-64K-2 . . . . . \$11.95  
Expands Model 4 from 16K-64K or Model 4P from 64K-128K  
TRS-64K-2PAL . . . . . \$29.95  
Expands Model 4 from 64K to 128K

**TRS-80 Model 100 • NEC • Olivetti**

M1008K . . . . . \$29.95 ea. or 3 for \$79.95  
TRS-80 Model 100 Expansion  
NEC8KR . . . . . \$29.95 ea. or 3 for \$79.95  
NEC Model PC-8201A Expansion  
OM108K . . . . . \$29.95 ea. or 3 for \$79.95  
Olivetti Model M10 Expansion

**TANDY 200**

M200R . . . . . \$74.95 ea. or 2 for \$129.95  
Tandy Model 200 Expansion

## UV-EPROM ERASER

Erases all EPROMs. Erases up to 8 chips within 21 minutes (1 chip in 15 minutes). Maintains constant exposure distance of 1" Special conductive foam liner eliminates static build-up. Built-in safety lock to prevent UV exposure. Compact - 9.00"L x 3.70"W x 2.60"H. Complete with holding tray for 8 chips.

**DE-4 UV-EPROM Eraser . . . . . \$74.95**  
**UVS-11EL Replacement Bulb . . . . . \$17.95**

## DATA BOOKS

30003 National Linear Data Book (82) . . . . . \$14.95  
30009 Intersil Data Book (85) . . . . . \$ 9.95  
30013 Zilog Data Book (85) . . . . . \$14.95  
30022 Nat'l Logic Data Book Set (84) . . . . . \$24.95  
210830 Intel Memory Handbook (86) . . . . . \$17.95  
230843 Intel Microsystem Hndbk. Set (86) . . . . . \$24.95

## MUFFIN/SPRITE-STYLE FANS

MUF60 (SPN3-15-2462) . . . . . \$9.95  
Howard Industries (4.68" sq. 60 cfm)  
SU2C7 . . . . . \$9.95  
EG&G Retron (3.125" square, 20 cfm)

**NEW!**

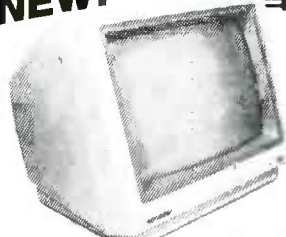

**13" Color Composite Monitor**  
for VIC-20 and C-64

Also compatible with other computers with composite output (i.e. Apple II, II+, IIe\*)  
Ideal for color graphics and games  
• Resolution: 260H x 300V • Recommended Display Character Number: 960 Characters (40 Characters x 24 Rows on 5x7 Dot Matrix)  
• CRT: 13" diagonal • Size: 14.6"W x 13.5"H x 15.5"D • Weight: 25.3 lbs.

**2 for**

**CMON . . . . . \$129.95 each or \$219.95**  
RCA-3-DIN (Universal Computer to Monitor Cables for Atari, Commodore & TI) . . . . \$3.49

## NEW PRODUCTS!

**ZUCKERBOARD Expansion Memory Half Card and Clock/Calendar for the Tandy 1000**



The Zuckerbord Expansion Memory Board allows you to expand the memory of your Tandy 1000 (128K Model) as much as 640K! 256K DRAM chips increase your computer's memory by either 256K or 512K, bringing your total system memory up to either 384K or 640K. The memory board also includes a DMA controller chip. Optional clock/calendar plugs directly onto the memory board. Manual included.

**TAN-Clock Clock/Calendar Option (only) . . . . . \$ 39.95**  
**TAN-EM256K Includes 256K RAM . . . . . \$ 99.95**  
**TAN-EM512K Includes 512K RAM . . . . . \$139.95**



**1MBYTE RAM CARD**  
for Apple II, II+ and IIe\*

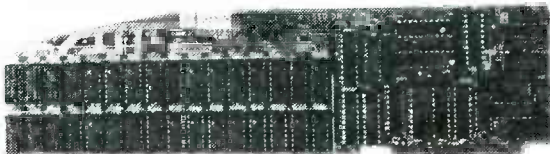

Introducing a third generation memory card that gives you both great expandability and great versatility at an extraordinary price. Versatility to users means that BIG BOARD is compatible with software written for the Syntex SSD (Flashcard) as well as for Jameco's JE868 128K RAM Card. BIG Board makes available 426K of worksheet space using the program THE Spreadsheet Version 2.0. It is compatible with PLUSWORKS XM for running Appleworks on the Apple II. Versatility also means that BIG BOARD comes complete with RAMDISK software for DOS 3.3, ProDOS, Pascal 1.2, and CP/M for Microsoft's Softcard. A separate driver is available for the AppliCard (StarCard).

**BIG BOARD-256K 256K RAM . . . . . \$199.95**  
**BIG BOARD-512K 512K RAM . . . . . \$249.95**  
**BIG BOARD-1M 1Meg RAM . . . . . \$299.95**

**1 Yr. Warranty!**

**estes**



**External Power Supply for the Commodore 64**

• Input: 117VAC @ 60Hz • Output: 5VDC @ 3 Amps, 10VAC @ 250mA • Short circuit protected and current limited • Transient spike suppression on 2 auxiliary 110VAC sockets  
• Switch on front serves as power switch for the computer and other peripherals  
• RFI/EMI filtered • Adjustable linear regulator  
• Has less than 50mV ripple rms at full load • 5 Amp primary fuse • Two conductor with ground line • Color: brown • Size: 7 1/2"D x 5 1/2"W x 2 1/2"H • Weight: 5 lbs.

**CPS-10 . . . . . \$39.95**

## IBM® COMPATIBLE ACCESSORIES

**83-KEY KEYBOARD**



• Identical layout as original IBM PC Keyboard • Highly desirable case with palm rest • Complete with cable and data  
• JUST PLUG IN!

**KB83 . . . . . \$39.95**

**Build an IBM PC/XT™ Compatible!**

**IBM-64K(2)** 64K RAM Chips (18) . . . . . \$ 24.98  
**KB-83** 83-Key Keyboard . . . . . \$ 39.95  
**IBM-FCC** Floppy Controller Card . . . . . \$ 49.95  
**IBM-Case** Case . . . . . \$ 49.95  
**IBM-MCC** Monochrome Card . . . . . \$ 89.95  
**IBM-PS** Power Supply . . . . . \$ 89.95  
**FD55B** Disk Drive . . . . . \$119.95  
**IBM-MON** Monochrome Monitor . . . . . \$109.95  
**IBM-MB** Motherboard . . . . . \$169.95

**Regular List \$744.58**

**IBM™-Special (Incl. 9 items above) . . . \$649.95**

**Additional Add-Ons Available!**

**IBM-KB** 83-Key Keyboard . . . . . \$ 79.95  
**IBM-ENH** Enhanced Keyboard . . . . . \$ 99.95  
**IBM-ICB** Integrated Color Board . . . . . \$109.95  
**IBM-EGA** Enhd. Graphics 256K RAM . . . . \$349.95  
**IBM-20MBK** 20MB Hard Disk Drive . . . . \$499.95

IBM is a registered trademark of IBM Computers

## NEW! Universal NEW! 64K/256K NEW! Printer Buffer

JOHNATHON FREEMAN DESIGNS



The **UBUFFER Universal Printer Buffer** is a hi-speed data buffer that accepts data at a high rate, and then outputs this data to your printer. You save valuable computer time. The UBUFFER can be connected to practically any computer or printer. There are four possible combinations: 1) Serial to Serial, 2) Serial to Parallel, 3) Parallel to Parallel, 4) Parallel to Serial. Manual included. Size: 9-1/8"L x 4 1/4"W x 1 1/2"H

**UBUFFER-64K . . . \$199.95**  
**UBUFFER-256K . . \$229.95**



**IBM Compatible! DISK DRIVES**  
Documentation Included

**FD55B** Teac 5 1/4" DS 1/2"-Height . . . . . \$119.95  
**SA455** Shugart 5 1/4" DS 1/2"-Height . . . . . \$119.95  
**TM100-2** Tandon 5 1/4" DS Full-Height . . . . \$139.95

**JMR 5 1/4" DISK DRIVE ENCLOSURES**

Complete with power supply, switch, power cord, fuseholder and connectors.  
**DDE-1FH** Houses 1 Full-Height 5 1/4" Floppy Drive . . . . . \$69.95  
**DDE-2HH** Houses 2 Half-Height 5 1/4" Floppy Drives - Vertical . . . . . \$79.95  
**HDDE-1FH** Houses 1 Hard Disk Drive . . . . . \$199.95

\$20 Minimum Order - U.S. Funds Only  
Shipping: Add 5% plus \$1.50 Insurance

California Residents: Add 6% or 6 1/2% Sales Tax  
CIRCLE 114 ON FREE INFORMATION CARD

Spec. Sheets - 30¢ each  
Prices Subject to Change

Send stamped, self-addressed envelope to receive a Quarterly Sales Flyer - FREE!



Send \$1.00 Postage for a FREE 1986 JAMECO CATALOG

©1986 Jameco Electronics

1355 SHOREWAY ROAD, BELMONT, CA 94002 • PHONE ORDERS WELCOME 415-592-8097 Telex: 176043

CIRCLE 114 ON FREE INFORMATION CARD

www.americanradiohistory.com

# MARK V ELECTRONICS INC.,

248 EAST MAIN STREET, SUITE 100,  
ALHAMBRA, CA 91801.  
TELEX: 3716914 MARK 5.

TOLL FREE FOR ORDERS PAID BY MASTER OR VISA CARD  
PLEASE CALL: 1-800-423-3483  
IN CALIFORNIA: 1-800-521-MARK  
INFORMATION: 1-818-282-1196  
MAIL ORDERS: P.O. BOX 7065 ALHAMBRA CA 91802.



## CALL OR WRITE FOR A FREE CATALOG — OVER 60 HOT & WELL-QUALIFIED ITEMS FOR YOUR SELECTION!

### TR-100 0-15V 2A REGULATED DC POWER SUPPLY



- Output voltage is adjustable from 0-15V DC, two current limit range are available for selection: 200mA or 2A.
  - An elaborated protection system is specially designed, a "BB" sound and a sparkle light will appear when the output is overloaded or short-circuit.
  - High stability and reliable resulting from employing high quality voltage regulate IC.
  - Possessing King size meter makes the reading of voltage and current more clearly and accuracy.
- A refined case, meter and all accessory are enclosed for both kit and assembly form. Most suitable for factory, professional or even amateur.

Kit ..... \$59.50  
Ass. with tested ..... \$69.50

### CORDLESS SOLDERING IRON RECHARGEABLE

No. 620



The most perfect handy, lightweight soldering iron for Workshop, Home, Hobby & Outdoor work.  
Includes UL approval charger & cleaning sponge.  
With build-in solder point illumination.

Each set ..... \$22.80

### TALKING CLOCK

NEW FOR 86'

GOLDEN & BLACK ARE AVAILABLE!

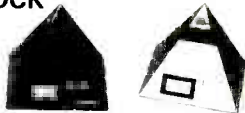

1. Talk: push button for voice announcement of time.
2. Read out: twelve hours system display for hour, minute, second (by color flash), AM & PM.
3. Display: three display modes of time, alarm time & date.
4. Alarm: on/off switch with thirty seconds voice alarm.
5. Snooze: reminder voice alarm of thirty seconds after 4 minutes of first voice alarm.
6. Volume: two level of voice output.
7. Language available: English, Mandarin.

Mynah 8504 ..... \$25.00 NOT A KIT!

### 3 1/2 DIGITAL MULTIMETER

YAMATO 4001



SPECIAL OFFER!

The YAMATO 4001 is a 3 1/2 DIGIT COMPACT DIGITAL MULTIMETER, it employs FE type LCD, with large figures. Its ADVANTAGES: High accuracy in measuring. High impedance assures min. measuring error. One rotary switch allows fast & convenient operation. 26 measurement range enable wider application. Over-input indication & low battery life appears on display. LSI-circuit use provides high reliability and durability. Measurement possible even under strong magnetic field.

Not a KIT, assembled with tested ..... \$33.80

### 80W + 80W DC LOW TIM PRE-MAIN AMPLIFIER

TA-800



Kit ..... \$49.85  
Metal Cabinet/X'Former (Optional) ..... \$23.90/\$22.00

### TA-1500 100W + 100W NEW CLASS 'A' DC STEREO PRE-MAIN AMPLIFIER



Features:

1. Preamp employs three LOW NOISE Op.Amp as RIAA equalizer and 20dB flat amplifier and tone control. It has very good transient response and low noise. It is easy to build up.
2. Power Amp. employs our powerful audio transistors and an advanced dynamic bass class 'A' circuit. The dissipation is extremely low and this makes the output stage at minimal switching distortion. It can reproduce high level bass faithfully.
3. A specially designed delay system is included and the functions contains: (a) three seconds delay, (b) output short circuit protection, (c) DC output protection. It also equipped with LED indicator of double display.
4. It includes a microphone mixer, so you can sing with those famous singers together. It can also be used as a Public Address Amplifier.

Kit ..... \$67.00  
Metal Cabinet/X'Former (Optional) ..... \$23.90/\$22.00

### 10W AC/DC SHOULDER AMPLIFIER

TA-008



TA-008 employs the most advanced I.C. of TOSHIBA, as a main device, the sound is powerful, it can be supplied by only 4 pieces of 'UM-1' 1.5V battery or AC to DC 6-9V adaptor. It is simple to operate, just 'press-to-talk', and with ON-OFF power switch on the mike. Besides, while it is well-packaged and with light weight, so it is convenient to bring along in both indoor and outdoor activities. Please Read our catalog for details.

Assembled with tested ..... \$48.00

### STEREO SIMULATOR

TA-3000



SPECIAL KITS OFFER!

KIT ONLY \$25.00 (Case included)

You can own a stereo TV from today! This simulator is a special design of using the most advanceable monopoles L.S.I. It produced a superior analog stereo effect since the L.S.I. is equalled 60 pcs. of LOW NOISE FET & TRANSISTOR. The simulator can even help you to promote your television from a normal one to a special one with a Hi-Fi STEREO function. Our simulator is also applicable to any other 'mono sources' in covering it to ANALOG STEREO. Undoubtedly, it is the most advanced equipment for every family, while it should contribute to your listening pleasure.

Ass. with tested ..... \$30.00

### COLOR LIGHT CONTROLLER

TY-23B



As a result of the advanced technology, this unit can control various colorful light bulbs, the visual effect of which is most suitable in places like party, disco, electronic game centre and also in lightings for advertisement. Total output power is 3000W (1000W Ch.) which means that it can control 30 pieces of 100W or 600 pieces of 5W color light which is enough for most usages.

Kit ..... \$65.00  
Ass. with tested ..... \$75.00

### TA-2400A ELECTRONIC ECHO AND REVERBERATION AMPLIFIER

REMIX records yourself!



This unit combines the most advanced V.L.S.I. technique with high quality Japan made components. It has the following FEATURES:

It can generate various reflection and reverb effects as those occurring in valleys and music halls, it has 3 special effect controls which include reverb control, delay control and depth control. Special effect can be made in your record tapes by using this model. All kinds of infeed sound effect can be obtained by skilful use of this control. It has LED display to show reflection and reverbation.

Ass. with tested ..... \$99.85

### HIGH QUALITY MULTIPURPOSE PRE-AMPLIFIER

TA-2500

GREAT VALUE!



This specially designed pre-amplifier includes a professional GRAPHIC EQUALIZER TONE control system and has a gain of ±12dB. Frequency response extends from 5Hz to 20KHz, so as to ensure best performance in whatever adverse condition. It can accept input from various magnetic cartridge, record deck, CD player and tuner; its output can be connected to all kinds of power amplifier!

Assembled with tested ..... \$82.00

### 120W MOSFET POWER AMPLIFIER

TA-477



This amplifier consists of three super low TIM differential stages, and Hitachi 2S149 25K 134 match pair "MOSFET" as output component whose frequency response and transient response is superior to the other power transistor. Therefore this amplifier has high-fidelity and superior analytic power over the entire Audio Spectrum. It is suitable for reproducing classic and modern music. Heavy Duty Heat Sink (with 28 radial fins is included!

Kit ..... \$55.00  
Metal Cabinet/X'Former (Optional) ..... \$23.90/\$19.88

Model No.	Description	Kit/Assembled	Unit Price	Model No.	Description	Kit/Assembled	Unit Price
TA-001	1W Mini Amplifier	Kit	\$3.90	TR-355 A, B	3-5A REGULATED DC POWER SUPPLY	Kit	\$10.68
TA-006	6W Mini Amplifier	Kit	\$4.92	TR-503	0-50V/3A POWER SUPPLY WITH SHORT CIRCUIT BREAK & OVERLOAD PROTECTOR	Kit	\$69.50
TA-007	12W Stereo Power Booster	Kit	\$8.00	TR-100	0-15V 2A REGULATED DC POWER SUPPLY	Kit	\$12.30
TA-008	AC/DC SHOULDER AMPLIFIER	Ass	\$48.00	TY-1A MK4	BATTERY FLUORESCENT LIGHT	Kit	\$3.99
TA-10	STEREO PRE-AMPLIFIER WITH MAGNETIC MIC AMP	Kit	\$6.00	TY-7	ELECTRONIC TOUCH SWITCH	Kit	\$5.50
TA-50 A, B	MULTI-PURPOSE MELODY GENERATOR	Kit	\$10.76	TY-11A	DIGITAL FUNCTIONAL CONTROL RELAY	Kit	\$3.99
TA-120	PURE CLASS "A" MAIN POWER AMPLIFIER	Ass	\$60.00	TY-12A	DIGITAL CLOCK WITH TWO TIMER	Kit	\$13.86
TA-202	20W AC/DC STEREO AMPLIFIER	Kit	\$25.00	TY-13	COLOR LED VU METER	Kit	\$3.00
TA-300	30W Multi-Purpose Single Channel Amp.	Ass	\$111.07	TY-14	ELECTRONIC SHOCK	Kit	\$7.68
TA-302	60W Stereo Power Booster	Kit	\$24.60	TY-18	HIGH PRECISION SOUND CONTROL SWITCH	Kit	\$19.50
TA-323A	High Quality 30W+30W Stereo Amplifier	Kit	\$29.50	TY-20	SUPER SENSITIVE AUDIO LEVEL INDICATOR	Kit	\$65.00
TA-322	60W IC Stereo Pre-Amplifier & Power Amplifier	Kit	\$13.84	TY-23B	COLOR LIGHT CONTROLLER	Ass	\$75.00
TA-400	40W TRANSISTORIZED MONO-AMPLIFIER	Kit	\$49.85	TY-25	SPEAKER PROTECTOR	Kit	\$5.50
TA-477	120W MOSFET POWER AMPLIFIER	Kit	\$39.95	TY-35	FM WIRELESS MICROPHONE	Kit	\$7.68
TA-800	160W DC LOW TIM PRE-AMPLIFIER & POWER AMP.	Kit	\$43.00	TY-36	AC/DC QUARTZ DIGITAL CLOCK	Kit	\$16.92
TA-802	150W PURE DC ST. POWER AMP. W/SPK. PROTECTOR	Kit	\$45.50	TY-38	SOUND OR TOUCH CONTROL SWITCH	Kit	\$10.00
TA-820A	120W OCL DC PRE-MAIN & STEREO AMPLIFIER	Kit	\$30.00	TY-41 MK(II)	INFRARED REMOTE CONTROL UNIT	Ass	\$30.00
TA-1000A	100W DYNAMIC CLASS "A" MAIN POWER AMP (MONO)	Kit	\$67.00	TY-42	BAR/DOT LEVEL METER	Kit	\$21.00
TA-1500	200W NEW CLASS "A" DC STEREO PRE-MAIN AMP	Ass	\$99.85	TY-47	BAR/DOT AUDIO LEVEL DISPLAY	Kit	\$34.95
TA-2400A	ELECTRONIC ECHO AND REVERBERATION AMP	Ass	\$82.00	YAMATO 4001	SUPERIOR ELECTRONIC ROULETTE	Kit	\$33.80
TA-2500	HIGH QUALITY MULTI-PURPOSE PRE-AMPLIFIER	Kit	\$38.00	T1	3 1/2 DIGITAL MULTIMETER	@ SET	\$20.00
TA-2500	DC FET SUPER CLASS "A" PRE-AMPLIFIER	Ass	\$36.80	T2	LCD THERMOMETER CLOCK W/F & C° MEASURING	@ SET	\$18.00
TA-2800	NF-CR BI-FET PRE-AMP (WITH 3WAY TONE CONTROL)	Ass	\$30.00	8504	TALKING CLOCK MYNAH (GOLDEN OR BLACK)	@ SET	\$25.00
TA-3000	STEREO SIMULATOR	Kit	\$25.00	NO. 620	CORDLESS SOLDERING IRON RECHARGEABLE	@ SET	\$22.80
SM-43	3 1/2 MULTI-FUNCTIONAL LED D.P.M.	Kit	\$29.23				
SM-48	4 1/2 HI-PRECISION D.P.M.	Ass	\$35.00				
SM-100	150MC UNIVERSAL DIGITAL FREQUENCY COUNTER	Kit	\$38.00				
TY-43	3 1/2 DIGITAL PANEL METER	Ass	\$43.00				
		Ass	\$99.00				
		Kit	\$28.00				

Ass=Assembled form, it is fully checked and tested.

TERMS: Minimum order: \$10.00. Charge card order \$20.00. No C.O.D.! Check & Money order, phone order accept. CA. residents must include 6.5% sales tax. Prices as subject to change without notice. All merchandise subject to prior sale. Shipping & handling: Inside L.A. 5% of total order (Min. \$1.50). Outside L.A. 10% of total order (Min. \$2.50). Outside U.S.A. 20% of total order (Min. \$5.00). Shipped by UPS ground. HOURS: Mon-Fri 9:30 to 5:00, Sat 9:30 to 1:00 (PACIFIC TIME)

NATION-WIDE DISTRIBUTORS WANTED FOR OUR PRODUCTS, QUANTITY DISCOUNTS AVAILABLE!

# ★ QUALITY PARTS ★ DISCOUNT PRICES ★ FAST SHIPPING! ★ ALL ELECTRONICS CORP.

SEND FOR  
**FREE**  
1986 CATALOG...  
**48 PAGES!**

## EDGE CONNECTORS

ALL ARE 1.56" SPACING.

- 22 EDGE CONNECTOR \$1.25 ea solder lug style 10 for \$11.00
- 22/44 EDGE CONNECTOR \$2.00 ea PC style 10 for \$18.00
- 22/44 EDGE CONNECTOR solder lug style \$2.50 each
- 28/56 EDGE CONNECTOR \$2.50 ea PC style 10 for \$22.00
- 36/72 EDGE CONNECTOR PC style \$3.00 each
- 43/86 EDGE CONNECTOR PC style \$4.50 each

## TRANSISTORS

- 2N706 4 for \$1.00
- 2N2222A 3 for \$1.00
- PN2222A 4 for \$1.00
- 2N2904 3 for \$1.00
- 2N2904 3 for \$1.00
- 2N2905 3 for \$1.00
- MJ2955 \$1.50
- 2N3055 \$1.00
- PMD 10K40 \$1.00
- TIP 121 75¢
- TIP 125 75¢

## TRANSFORMERS

- 120 volt primaries
- 5.6 volts @ 750 ma. \$3.00
- 6 volts @ 150 ma. \$1.25
- 6.3 volt @ 500 ma. \$3.00
- 12 V.C.T. @ 200 ma. \$2.00
- 12 V.C.T. @ 400 ma. \$3.00
- 12 V.C.T. @ 1 amp \$4.00
- 12 V.C.T. @ 2 amp \$4.85
- 16 volts @ 4 amp \$7.00
- 16 volts @ 650 ma. \$3.50
- 24 V.C.T. @ 200 ma. \$4.85
- 24 V.C.T. @ 1 amp \$2.50
- 24 V.C.T. @ 2 amp \$6.75
- 24 V.C.T. @ 3 amp \$9.50
- 24 V.C.T. @ 4 amp \$11.00
- 36 V.C.T. @ 135 ma. \$3.00

## WALL TRANSFORMERS

- all plug directly into 120 vac outlet
- 4 VDC @ 70 ma. \$2.00
- 6 VDC @ 500 ma. \$3.50
- 8 VDC @ 750 ma. \$4.50
- 9 VDC @ 500 ma. \$5.00
- 12.5 VAC @ 265 ma. \$3.00
- 18 VAC @ 18 VA and 8.5 VAC @ 1.28 VA \$3.50
- 24 VAC @ 250 ma. \$3.00
- MULTI-VOLTAGE @ 500 ma. 3, 4, 6, 7, 9, 12 VDC \$7.50

## MINI-BOX

Pomona #2104  
Heavy-duty black phenolic project box with cover and screws. 2 3/4" X 1 1/2" X 1 1/2"

## FUSES

- 3AG (AGC) SIZE 1, 1 1/2, 2, 2 1/2, 3, 4, 5, 6 AMP
- GMA SIZE 1, 2, 3, 4, 5 AMP
- 5 of any ONE amperage 75¢



## SOUND AND VIDEO MODULATOR FOR T.I. COMPUTER

T.I. # UM1381-1. Designed for use with T.I. computers. Can be used with video sources. Built-in A/B switch. Channel 3 or 4 selection switch. Operate on 12 vdc. Hook-up diagram included.

CAT# AVMOD WERE \$10.00 **REDUCED TO \$5.00 EACH**

## SLIM LINE COOLING FAN

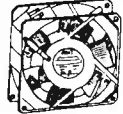

Etr # \$99KM182 low noise fan. Measures 3 3/4" square x 1" deep. 21 cfm. 23 db. 1700 rpm.

SPECIAL PRICE ... \$12.50 each

## 2K 10 TURN

MULTI-TURN POT SPECTROL #MOD 534-7161 \$5.00 EACH

## SOLID STATE BUZZER



Star # SMB-06L 6 vdc TTL compatible. \$1.00 each 10 for \$9.00

## ± 12 Vdc or 24Vdc POWER SUPPLY

DELTRON MODEL QD12/15-1.7 Dual plus and minus 12Vdc open frame power supply. Can be used as 24Vdc @ 1.5 amp. INPUT: either 115 Vac or 230 Vac. Fully regulated computer grade supply. 7" x 4 3/4" x 2 3/4"

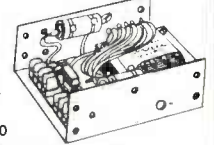

\$12.50 each 10 for \$110.00

## SPECIALS

1 AMP 50 VOLT DIODES IN4001 TAPE AND REEL 100 for \$4.50 1000 for \$30.00

SOLDER TAIL I.C. SOCKETS 24 PIN 10 for \$2.50 100 for \$22.00 1000 for \$200.00

## \* SPECIAL PRICE \* TRANSISTOR

plastic transistor PN3569 TO-92 N.P.N. 100 for \$8.00 1000 for \$60.00 LARGE QUANTITIES AVAILABLE

## MICRO-CASSETTE MECHANISM

Micro-cassette tape transport for standard MC60 or MC45 micro-cassettes. 3 Vdc operation. Contains: drive motor, bell, head, Capstan, pinch wheel and other components. 3 1/2" X 2 1/4" X 5/8" CAT# MCMEC \$3.00 each 10 for \$27.50

## COMPUTER GRADE CAPACITORS

- 2,000 mfd. 200 Vdc 1 3/4" x 5" high \$2.00
- 6,400 mfd. 60 Vdc 1 3/8" x 3 3/4" high \$2.50
- 9,700 mfd. 50 Vdc 1 3/8" x 4 1/2" high \$3.00
- 31,000 mfd. 15 Vdc 1 3/4" x 4" high \$2.50
- 50,000 mfd. 40 Vdc 3" x 3 3/4" high \$4.50
- 60,000 mfd. 40 Vdc 3" x 5" high \$3.50
- 66,000 mfd. 15 Vdc 3" x 3 3/4" high \$3.00
- 86,000 mfd. 30 Vdc 3" x 5 1/4" high \$3.50

## \$1.00 SPECIALS

- 5,500 mfd. 30 Vdc 1 3/8" x 3 1/2" high \$1.00
- 5,900 mfd. 30 Vdc 1 3/8" x 2 1/4" high \$1.00
- 9,300 mfd. 50 Vdc 2" x 4 1/2" high \$1.00
- 18,000 mfd. 10 Vdc 1 3/8" x 2 5/8" high \$1.00
- 48,000 mfd. 10 Vdc 2 1/2" x 3 1/4" high \$1.00
- 100,000 mfd. 10 Vdc 2 1/2" x 6" high \$1.00
- 185,000 mfd. 6 Vdc 2 1/2" x 4 1/2" high \$1.00

## RELAYS

10 AMP SOLID STATE CONTROL: 3-32 vdc LOAD: 140 vac 10 amp SIZE: 2 1/4" x 3/4" x 1/2"

## ULTRA-MINIATURE 5 VDC RELAY

Fujitsu # FBR211NED005M20 High sensitivity COIL: 120 ohms Energy coil to mounts in 14 pin DIP socket \$1.25 each 10 for \$10.00

## MINIATURE 6 VDC RELAY

Aromat #RSD-6V Super Small S.P.D.T relay G.O. cobalt contacts rated 1 amp @ 30 vdc. Highly sensitive. TTL direct drive possible. 120 ohm coil. Operate from 4.3 - 6 vdc. COIL: 120 ohms \$1.50 each 10 for \$13.50

## 13 VDC RELAY

CONTACTS: S.P.N.C. 10 amp @ 120 vac Energy coil to open contact. COIL: 13 vdc 650 ohms

## 4PDT RELAY

14 pin KH style... 3 amp contacts... USED but fully tested... \$1.70 each Specify coil voltage desired Either 24 vdc or 120 vac LARGE QUANTITIES AVAILABLE SOCKETS FOR KH RELAY 75¢ each

## RECHARGEABLE NI-CAD BATTERIES

- AAA SIZE 1.25V 500MAH \$1.85
- AA SIZE 1.25V 500MAH \$1.85
- AA with solder tab \$2.00
- C SIZE 1.2V 1200MAH \$3.50
- SUB-C SIZE solder tab \$3.50
- O SIZE 1.2V 1200MAH \$3.50

## UNIVERSAL CHARGER

Will charge 4-AA, C, D, or AAA ni-cads or one 9 volt ni-cad at one time... \$11.00 per charger

## PHOTO-FLASH CAPACITORS

- 170 ml 330v 75¢ ea.
- CAT# PPC-170
- 400 ml 330v 1.00 ea.
- CAT# PPC-400
- 800 ml 330v 1.35 ea.
- CAT# PPC-800

## 3 1/2" SPEAKER

8 ohm impedance. Full range speaker. 8 oz magnet 4" diagonal mounting centers \$2.50 each 10 for \$20.00

## SPRING LEVER TERMINALS

Two color coded terminals on a sturdy 2 3/4" x 3 3/4" bakelite plate. Great for speaker enclosures or power supplies. 75¢ EACH 10 for \$6.00

## LINE CORDS

- TWO WIRE 6' 18/2 SPT-1 flat 3 for \$1.00 6' 16/2 SPT-2 flat 2 for \$1.00 6' 16/2 SJT round \$1.25 each
- THREE WIRE 6' 18/3 flat \$1.50 each 8' 18/3 round \$2.00 each

## 7 CONDUCTOR RIBBON CABLE

Spectra-strip red marker strip. 28 ga. stranded wire. \$5.00 per 100' roll

## XENON FLASH TUBE

3/4" long X 1/8" dia. Flash tube designed for use in compact camera flash units. Ideal for experimenters. CAT# FLT-1 2 for \$1.00

## MINIATURE TOGGLE SWITCHES

- S.P.D.T. (on-on) PC style non-threaded bushing \$1.00 each 10 for \$7.00
- S.P.D.T. (on-on) Solder lug terminals \$1.00 each 10 for \$9.00 100 for \$80.00
- S.P.D.T. (on-off-on) Solder lug terminals \$1.00 each 10 for \$9.00 100 for \$80.00
- S.P.D.T. (on-off-on) PC style non-threaded bushing \$1.00 each 10 for \$7.00
- S.P.D.T. (on-on) threaded bushing \$1.00 each 10 for \$9.00 100 for \$80.00
- D.P.D.T. (on-on) Solder lug terminals \$2.00 each 10 for \$19.00 100 for \$180.00

## TI SWITCHING POWER SUPPLY

Compact, well-regulated switching power supply designed to power Texas Instruments computer equipment. INPUT: 14 - 25 vac @ 1 amp OUTPUT: +12 vdc @ 350 ma + 5 vdc @ 1.2 amp - 5 vdc @ 200 ma SIZE: 4 3/4" x 4 1/4" x 1 1/4" high \$3.50 each

## 13.8 VDC REGULATED POWER SUPPLY

These are solid state, fully regulated 13.8 vdc power supplies. Both feature 100% solid state construction, fuse protection, and L.E.D. power indicator. U.L. listed. 2 amp constant, 4 amp surge \$20.00 each 3 amp constant, 5 amp surge \$27.50 each

## D.C. CONVERTER

Designed to provide a steady ±5 vdc @ 240 ma. from a battery supply of 3.5 to 6.25 volts. 2 1/16" x 1 1/16" x 1 1/16" \$1.50 each

## TWIST-LOCK CONNECTOR

Same as Switchcraft #12CL5M. 5 conductor in-line plug and chassis mount jack. Twist-lock style. \$2.50/SET

## ALL ELECTRONICS CORP.

LOS ANGELES, CA STORE 905 S. Vermont Ave. 213 380-8000  
VAN NUYS, CA STORE 6228 Sepulveda Blvd. 818 997-1806

MAIL ORDERS TO: P.O. BOX 20406 Los Angeles, CA 90006  
TWX - 5101010163 ALL ELECTRONIC EASYLINK MBX - 62887748

TOLL FREE ORDERS ONLY 1-800-826-5432 (ORDER ONLY) (IN CALIFORNIA: 1-800-258-6666) ALASKA, HAWAII, OR INQUIRY (213) 380-8000 NO C.O.D.!

QUANTITIES LIMITED MINIMUM ORDER \$10.00 USA: \$3.00 SHIPPING FOREIGN ORDERS: INCLUDING SUFFICIENT SHIPPING CALIF. RES. ADD 6 1/2%

# 20MB HARD DISK SYSTEM ONLY \$38995!

### STATIC RAMS

2101	256x4	(450ns)	1.95
5101	256x4	(450ns)(CMOS)	3.95
2102L4	1024x1	(450ns)(LP)	.99
2112	256x4	(450ns)	2.99
2114	1024x4	(450ns)	1.99
2114L-4	1024x4	(450ns)(LP)	1.09
2114L-2	1024x4	(200ns)(LP)	1.49
2114L-15	1024x4	(150ns)(LP)	1.95
TMS4044-4	4096x1	(450ns)	1.95
TMM2016-150	2048x8	(150ns)	1.49
TMM2016-100	2048x8	(100ns)	1.95
HM6116-4	2048x8	(200ns)(CMOS)	1.89
HM6116-3	2048x8	(150ns)(CMOS)	1.95
HM6116LP-4	2048x8	(200ns)(CMOS)(LP)	1.95
HM6116LP-3	2048x8	(150ns)(CMOS)(LP)	2.05
HM6116LP-2	2048x8	(120ns)(CMOS)(LP)	2.95
HM6264P-15	8192x8	(150ns)(CMOS)	3.89
HM6264LP-15	8192x8	(150ns)(CMOS)(LP)	3.95
HM6264LP-12	8192x8	(120ns)(CMOS)(LP)	4.49

LP-Low power

### DYNAMIC RAMS

4116-250	16384x1	(250ns)	.49
4116-200	16384x1	(200ns)	.89
4116-150	16384x1	(150ns)	.99
4116-120	16384x1	(120ns)	1.49
MK4332	32768x1	(200ns)	6.95
4164-200	65536x1	(200ns)(5v)	1.19
4164-150	65536x1	(150ns)(5v)	1.29
4164-120	65536x1	(120ns)(5v)	1.75
MCM6665	65536x1	(200ns)(5v)	1.95
TMS4164	65536x1	(150ns)(5v)	1.95
4164-REFRESH	65536x1	(150ns)(5v)(REFRESH)	2.95
TMS4416	16384x1	(150ns)(5v)	4.95
41128-150	131072x1	(150ns)(5v)	6.95
TMS4464-15	65536x4	(150ns)(5v)	6.95
41256-200	262144x1	(200ns)(5v)	2.95
41256-150	262144x1	(150ns)(5v)	2.95

5v=Single 5 Volt Supply REFRESH=Pin 1 Refresh

★★★★HIGH-TECH★★★★

## NEC V20 UPD70108 \$1195

REPLACES 8088 TO SPEED UP IBM PC 10-40%

- \* HIGH-SPEED ADDRESS CALCULATION IN HARDWARE
- \* PIN COMPATIBLE WITH 8088
- \* SUPERSET OF 8088 INSTRUCTION SET
- \* LOW POWER CMOS

**8MHZ V20 UPD70108-8 \$13.95**  
**8MHZ V30 UPD70116-8 \$19.95**

★★★★SPOTLIGHT★★★★

### EPROMS

2708	1024x8	(450ns)	4.95
2716	2048x8	(450ns)(5V)	3.49
2716-1	2048x8	(350ns)(5V)	3.95
TMS2532	4096x8	(450ns)(5V)	5.95
2732	4096x8	(450ns)(5V)	3.95
2732A	4096x8	(200ns)(5V)(21V PGM)	3.95
2732A-2	4096x8	(200ns)(5V)(21V PGM)	4.25
27C64	8192x8	(250ns)(5V)(CMOS)	5.95
2764	8192x8	(450ns)(5V)	3.49
2764-250	8192x8	(250ns)(5V)	3.95
2764-200	8192x8	(200ns)(5V)	4.25
MCM68766	8192x8	(350ns)(5V)(24 PIN)	17.95
27128	16384x8	(250ns)(5V)	4.25
27C256	32768x8	(250ns)(5V)(CMOS)	10.95
27256	32768x8	(250ns)(5V)	7.49

5V=Single 5 Volt Supply 21V PGM=Program at 21 Volts

## ORDER TOLL FREE 800-538-5000



### SPECTRONICS CORPORATION EPROM ERASERS



Model	Timer	Capacity Chip	Intensity (uW Cm <sup>2</sup> )	Unit Price
PE-14	NO	9	8,000	\$83.00
PE-14T	YES	9	8,000	\$119.00
PE-24T	YES	12	9,600	\$175.00

### 8080

8035	1.49
8039	1.95
8080	2.95
8085	2.49
8087-2	169.95
8087	129.00
8088	6.95
8088-2	9.95
8155	2.49
8155-2	3.95
8748	7.95
8755	14.95
80286	129.95
80287	199.95

### 6500 1.0 MHZ

6502	2.69
65C02(CMOS)	12.95
6507	9.95
6520	1.95
6522	4.95
6526	26.95
6532	6.95
6545	6.95
6551	5.95
6561	19.95
6581	34.95

### CRT CONTROLLERS

6845	4.95
68B45	8.95
6847	11.95
HD46505SP	6.95
MC1372	2.95
	3.2768
	3.579545
7220	19.95
4.032	4.00
5.0688	1.95
6.0	1.95
2.0 144	1.95
6.5536	1.95
8.0	1.95
10.0	1.95
10.738635	1.95
12.0	1.95
14.31818	1.95
15.0	1.95
16.0	1.95
17.95	12.95
17.97	12.95
27.91	19.95
27.93	19.95
27.97	29.95
6843	19.95
8272	4.95
UPD765	4.95
MB8876	12.95
MB8877	12.95
1691	6.95
2143	6.95

### CRYSTALS

32.768 KHz	.95
1.0 MHz	2.95
1.8432	2.95
2.0	1.95
2.097152	1.95
2.4576	1.95
3.2768	1.95
3.579545	1.95
4.0	1.95
4.032	1.95
5.0	1.95
5.0688	1.95
6.0	1.95
6.144	1.95
6.5536	1.95
8.0	1.95
10.0	1.95
10.738635	1.95
12.0	1.95
14.31818	1.95
15.0	1.95
16.0	1.95
17.95	12.95
17.97	12.95
27.91	19.95
27.93	19.95
27.97	29.95
22.1184	1.95
24.0	1.95
32.0	1.95

### 74LS00

74LS00	.16
74LS01	.16
74LS02	.17
74LS03	.18
74LS04	.16
74LS05	.18
74LS08	.18
74LS09	.18
74LS10	.16
74LS11	.22
74LS12	.22
74LS13	.26
74LS14	.39
74LS15	.26
74LS20	.17
74LS21	.22
74LS22	.27
74LS27	.25
74LS28	.26
74LS30	.17
74LS32	.18
74LS33	.28
74LS37	.26
74LS38	.26
74LS42	.39
74LS47	.75
74LS48	.85
74LS51	.17
74LS53	.29
74LS74	.24
74LS75	.29
74LS76	.29
74LS82	.49
74LS85	.49
74LS86	.22
74LS90	.39
74LS92	.49
74LS93	.39
74LS95	.49
74LS107	.34
74LS109	.36
74LS112	.29
74LS122	.45
74LS123	.49
74LS124	2.75
74LS125	.39
74LS126	.39
74LS132	.49
74LS133	.49
74LS136	.39
74LS138	.39
74LS139	.39
74LS145	.99
74LS147	.99
74LS148	.99
74LS151	.39
74LS153	.39
74LS154	1.49
74LS155	.59
74LS156	.49
74LS157	.35
74LS158	.29
74LS161	.39
74LS162	.49
74LS163	.39
74LS164	.49

### HIGH SPEED CMOS

A new family of high speed CMOS logic featuring the speed of low power Schottky, 3ns typical gate propagation delay, combined with the advantages of CMOS: very low power consumption; superior noise immunity, and improved output drive.

### 74HC00

74HC: Operate at CMOS logic levels and are ideal for new, all-CMOS designs.

74HC00	.59	74HC148	1.19
74HC02	.59	74HC151	.89
74HC04	.59	74HC154	2.49
74HC08	.59	74HC157	.89
74HC10	.59	74HC158	.95
74HC14	.79	74HC163	1.15
74HC20	.59	74HC175	.99
74HC27	.59	74HC240	1.89
74HC30	.59	74HC244	1.89
74HC32	.69	74HC245	1.89
74HC51	.69	74HC257	.85
74HC74	.75	74HC259	1.39
74HC85	1.35	74HC273	1.89
74HC86	.69	74HC299	4.99
74HC93	1.19	74HC368	.99
74HC107	.79	74HC373	2.29
74HC109	.79	74HC374	2.29
74HC112	.79	74HC390	1.39
74HC125	1.19	74HC393	1.39
74HC132	1.19	74HC4017	1.99
74HC133	.69	74HC4020	1.39
74HC138	.99	74HC4049	.89
74HC139	.99	74HC4050	.89

### 74HCT00

74HCT: Direct, drop-in replacements for LS TTL and can be intermixed with 74LS in the same circuit.

74HCT00	.69	74HCT166	3.05
74HCT02	.69	74HCT174	1.09
74HCT04	.69	74HCT193	1.39
74HCT08	.69	74HCT194	1.19
74HCT10	.69	74HCT240	2.19
74HCT11	.69	74HCT241	2.19
74HCT127	.69	74HCT244	2.19
74HCT30	.69	74HCT245	2.19
74HCT32	.79	74HCT257	2.09
74HCT75	.95	74HCT273	2.09
74HCT138	1.15	74HCT367	1.09
74HCT139	1.15	74HCT373	2.48
74HCT154	2.99	74HCT374	2.49
74HCT157	.99	74HCT393	1.59
74HCT158	.99	74HCT4017	2.19
74HCT161	1.29	74HCT4040	1.59
74HCT164	1.39	74HCT4060	1.49

### 8200

8203	24.95
8205	3.29
8212	1.49
8216	1.49
8224	2.25
8237	4.49
8237-5	5.49
8250	6.95
8251	1.69
8251A	1.99
8253	1.89
8253-5	1.95
8255	1.69
8255-5	1.89
8259	1.95
8259-5	2.29
8272	4.95
8279	2.49
8279-5	2.95
8282	3.95
8284	2.95
8286	3.95
8288	4.95

### 2.0 MHZ

6502A	2.95
6520A	2.95
6522A	5.95
6532A	11.95
6545A	7.95
6551A	6.95

### DISK CONTROLLERS

1771	4.95
1791	9.95
1793	9.95
1795	12.95
1797	12.95
2791	19.95
2793	19.95
2797	29.95
6843	19.95
8272	4.95
UPD765	4.95
MB8876	12.95
MB8877	12.95
1691	6.95
2143	6.95

### CRYSTAL OSCILLATORS

1.0MHz	5.95
1.8432	5.95
2.0	5.95
2.097152	5.95
2.4576	5.95
3.2768	5.95
3.579545	5.95
4.0	5.95
4.032	5.95
5.0	5.95
5.0688	5.95
6.0	5.95
6.144	5.95
6.5536	5.95
8.0	5.95
10.0	5.95
10.738635	5.95
12.0	5.95
14.31818	5.95
15.0	5.95
16.0	5.95
17.95	12.95
17.97	12.95
27.91	19.95
27.93	19.95
27.97	29.95
22.1184	5.95
24.0	5.95
32.0	5.95

### 74LS00

74LS00	.16
74LS01	.16
74LS02	.17
74LS03	.18
74LS04	.16
74LS05	.18
74LS08	.18
74LS09	.18
74LS10	.16
74LS11	.22
74LS12	.22
74LS13	.26
74LS14	.39
74LS15	.26
74LS20	.17
74LS21	.22
74LS22	.27
74LS27	.25
74LS28	.26
74LS30	.17
74LS32	.18
74LS33	.28
74LS37	.26
74LS38	.26
74LS42	.39
74LS47	.75
74LS48	.85
74LS51	.17
74LS53	.29
74LS74	.24
74LS75	.29
74LS76	.29
74LS82	.49
74LS85	.49
74LS86	.22
74LS90	.39
74LS92	.49
74LS93	.39
74LS95	.49
74LS107	.34
74LS109	.36
74LS112	.29
74LS122	.45
74LS123	.49
74LS124	2.75
74LS125	.39
74LS126	.39
74LS132	.49
74LS133	.49
74LS136	.39
74LS138	.39
74LS139	.



# 20MB HARD DISK SYSTEM ONLY \$38995!

CMOS			
4001	.19	14419	4.95
4011	.19	14433	14.95
4012	.25	4503	.49
4013	.35	4511	.69
4015	.29	4516	.79
4016	.29	4518	.89
4017	.49	4522	.79
4018	.69	4526	.79
4020	.59	4527	1.95
4021	.69	4528	.79
4024	.49	4529	2.95
4025	.25	4532	1.95
4027	.39	4538	.95
4028	.65	4541	1.29
4035	.69	4553	5.79
4040	.69	4585	.75
4041	.75	4702	12.95
4042	.59	74C00	.29
4043	.85	74C14	.59
4044	.69	74C74	.59
4045	1.98	74C83	1.95
4046	.69	74C85	1.49
4047	.69	74C95	.99
4049	.29	74C150	5.75
4050	.29	74C151	2.25
4051	.69	74C161	.99
4052	.69	74C163	.99
4053	.69	74C164	1.39
4056	2.19	74C192	1.49
4060	.69	74C193	1.49
4066	.29	74C221	2.49
4069	.19	74C240	1.89
4076	.59	74C244	1.89
4077	.29	74C374	1.99
4081	.22	74C905	10.95
4085	.79	74C911	8.95
4086	.89	74C917	12.95
4093	.49	74C922	4.49
4094	2.49	74C923	6.95
14411	9.95	74C926	7.95
14412	6.95	80C97	.95

7400/9000			
7400	.19	74147	2.49
7402	.19	74148	1.20
7404	.19	74150	1.35
7406	.29	74151	.55
7407	.29	74153	.55
7408	.24	74154	1.49
7410	.19	74155	.75
7411	.25	74157	.55
7414	.49	74159	1.65
7416	.25	74161	.69
7417	.25	74163	.69
7420	.19	74164	.85
7423	.29	74165	.85
7430	.19	74166	1.00
7432	.29	74175	.89
7438	.29	74177	.75
7442	.49	74178	1.15
7445	.69	74181	2.25
7447	.89	74182	.75
7470	.35	74184	2.00
7473	.34	74191	1.15
7474	.33	74192	.79
7475	.45	74194	.85
7476	.35	74196	.79
7483	.50	74197	.75
7485	.59	74199	1.35
7486	.35	74221	1.35
7489	2.15	74246	1.35
7490	.39	74247	1.25
7492	.50	74248	1.85
7493	.35	74249	.95
7495	.55	74251	1.75
7497	2.75	74265	1.35
74100	2.29	74273	1.95
74121	.29	74278	3.11
74123	.49	74267	.65
74125	.45	74368	.65
7411	.65	9368	3.95
74143	5.95	9602	1.50
74144	2.95	9637	2.95
74145	.60	96502	1.95

74S00			
74500	.29	745163	1.29
74502	.29	745168	3.95
74503	.29	745174	.79
74504	.29	745175	.79
74505	.29	745188	1.95
74506	.35	745199	1.05
74510	.29	745195	1.49
74515	.49	745196	2.45
74530	.29	745197	2.95
74532	.35	745226	3.99
74537	.69	745240	1.49
74538	.69	745241	1.49
74574	.49	745244	1.49
74585	.95	745257	.79
74586	.95	745258	.79
745112	.50	745258	.95
745124	2.75	745280	1.95
745138	.79	745287	1.69
745140	.55	745288	1.69
745151	.79	745299	2.95
745153	.79	745373	1.69
745157	.79	745374	1.69
745158	.95	745471	4.95
745161	1.29	745571	2.95

VOLTAGE REGULATORS			
TO-220 CASE			
7805T	.49	7905T	.59
7808T	.49	7908T	.59
7812T	.49	7912T	.59
7815T	.49	7915T	.59
TO-3 CASE			
7805K	1.59	7905K	1.69
7812K	1.39	7912K	1.49
TO-93 CASE			
78L05	.49	79L05	.69
78L12	.49	79L12	1.49
OTHER VOLTAGE REGS			
LM323K	5V 3A	TO-3	4.79
LM328K	Adj. 5A	TO-3	3.95
78H05K	5V 5A	TO-3	7.95
78H12K	12V 5A	TO-3	8.95
78P05K	5V 10A	TO-3	14.95

LINEAR			
TL066	.69	LM733	.98
TL071	.99	LM741	.29
TL072	1.09	LM747	.69
TL074	1.95	LM748	.59
TL081	.59	MC1330	1.69
TL082	.99	MC1350	1.19
TL084	1.49	MC1372	6.95
LM301	.34	LM1414	1.59
LM309K	1.25	LM1458	.49
LM311	.59	LM1488	.49
LM311H	.89	LM1489	.49
LM317K	3.49	LM1496	.85
LM317T	.59	LM1812	8.25
LM318	1.49	LM1889	1.95
LM319	1.25	ULN2003	.79
LM320	1.90	XR2206	3.95
LM322	1.95	XR2211	2.95
LM323K	4.79	XR2240	1.95
LM324	.49	MPQ2907	1.95
LM331	3.95	LM2917	1.95
LM334	1.19	CA3046	.89
LM335	1.79	CA3081	.99
LM336	1.75	CA3082	.99
LM337K	3.95	CA3086	.80
LM338K	6.95	CA3089	1.95
LM339	.59	CA3130E	.99
LM340	see 7800	CA3146	1.29
LM350T	4.60	CA3160	1.19
LF353	.59	MC3470	1.95
LF356	.99	MC3480	8.95
LF357	.99	MC3487	2.95
LM358	.59	LM3900	.49
LM380	.89	LM3909	.99
LM383	1.95	LM3911	2.25
LM386	.89	LM3914	2.39
LM393	.45	MC4024	3.49
LM394H	5.95	MC4044	3.99
TL494	4.20	RC4136	1.25
TL497	3.25	RC4558	.69
NE555	.29	LM13600	1.49
NE556	.49	75107	1.49
NE558	1.29	75110	1.95
NE564	1.95	75150	1.95
LM565	.95	75154	1.95
LM566	1.49	75188	1.25
LM567	.79	75189	1.25
NE570	2.95	75451	3.99
NE590	2.50	75452	.39
NE592	.98	75453	.99
LM710	.75	75477	1.29
LM723	.49	75492	.79
H=TO-5 CAN, K=TO-3, T=TO-220			

IC SOCKETS			
8 PIN ST	.11	100	.10
14 PIN ST	.11	.09	
16 PIN ST	.12	.10	
18 PIN ST	.15	.13	
20 PIN ST	.18	.15	
22 PIN ST	.15	.12	
24 PIN ST	.20	.15	
28 PIN ST	.22	.16	
40 PIN ST	.30	.22	
64 PIN ST	1.95	1.49	
ST-SOLDERABLE			
8 PIN WW	.59	.69	
14 PIN WW	.69	.52	
16 PIN WW	.69	.58	
18 PIN WW	.99	.90	
20 PIN WW	1.09	.98	
22 PIN WW	1.39	1.28	
24 PIN WW	1.49	1.35	
28 PIN WW	1.69	1.49	
40 PIN WW	1.99	1.80	
WW-WIREWRAP			
16 PIN ZIF	4.95	CALL	
24 PIN ZIF	5.95	CALL	
28 PIN ZIF	6.95	CALL	
40 PIN ZIF	9.95	CALL	
ZIF-TEXT TOOL (ZERO INSERTION FORCE)			

DATA ACQ INTERFACE			
ADC0800	15.55	8T26	1.29
ADC0804	3.49	8T26	1.29
ADC0809	4.49	8T95	.89
ADC0816	14.95	8T96	.89
ADC0817	9.95	8T97	.59
ADC0831	8.95	8T98	.89
DAC0800	4.49	DM8131	2.95
DAC0806	1.95	DP8304	2.29
DAC0808	2.95	DS8833	2.25
DAC1020	8.25	DS8835	1.99
DAC1022	5.95	DS8836	.99
MC1408L8	2.95	DS8837	1.65

EDGE CARD CONNECTORS			
100 PIN ST	S-100	125	3.95
100 PIN WW	S-100	125	4.95
62 PIN ST	IBM PC	100	1.95
50 PIN ST	APPLE	100	2.95
44 PIN ST	STD	156	1.95
44 PIN WW	STD	156	4.95

36 PIN CENTRONICS			
MALE			
IDCEN36	RIBBON CABLE	6.95	
CEN36	SOLDER CUP	4.95	
FEMALE			
IDCEN36F	RIBBON CABLE	7.95	
CEN36PC	RT ANGLE PC MOUNT	4.95	

INTERSIL			
ICL7106	9.95		
ICL7107	12.95		
ICL7660	2.95		
ICL8038	4.95		
ICM7207A	5.95		
ICM7208	15.95		

DIP CONNECTORS										
DESCRIPTION	ORDER BY	CONTACTS								
		8	14	16	18	20	22	24	28	40
HIGH RELIABILITY TOOLED ST IC SOCKETS	AUGATxxST	62	79	89	1.09	1.29	1.39	1.49	1.69	2.49
HIGH RELIABILITY TOOLED WW IC SOCKETS	AUGATxxWW	1.30	1.80	2.10	2.40	2.50	2.30	3.15	3.70	5.40
COMPONENT CARRIES (DIP HEADERS)	ICCxx	.49	.59	.69	.99	.99	.99	.99	1.09	1.49
RIBBON CABLE DIP PLUGS (IDC)	IDPxx	---	.95	.95	---	---	---	1.75	---	2.95

FOR ORDERING INSTRUCTIONS SEE D-SUBMINIATURE BELOW

DIODES/OPTO/TRANSISTORS			
1N751	.25	4N26	.69
1N759	.25	4N27	.69
1N4148	25/1.00	4N28	.69
1N4004	10/1.00	4N33	.89
1N5402	.25	4N37	1.19
KB904	.55	MCT-2	.59
KB10A	.95	MCT-6	1.29
MDA990-2	.35	TIL-111	.99
N2222	.25	2N3906	.10
PN2222	.10	2N4401	.25
2N2905	.50	2N4402	.25
2N2907	.25	2N4403	.25
2N3055	.79	2N6405	1.75
2N3904	.10	TIP31	.49

D-SUBMINIATURE								
DESCRIPTION	ORDER BY	CONTACTS						
		9	15	19	25	37	50	
SOLDER CUP	MALE	DBxxP	82	90	1.25	1.80	3.48	
	FEMALE	DBxxS	95	1.15	1.50	1.50	2.35	4.32
RIGHT ANGLE PC SOLDER	MALE	DBxxPR	1.20	1.49	---	1.95	2.65	---
	FEMALE	DBxxSR	1.25	1.55	---	2.00	2.79	---
WIRE WRAP	MALE	DBxxPWW	1.69	2.56	---	3.89	5.70	---
	FEMALE	DBxxSWW	2.76	4.27	---	6.84	9.95	---
IDC RIBBON CABLE	MALE	IDBxxP	2.70	2.95	---	3.98	5.70	---
	FEMALE	IDBxxS	2.92	3.20	---	4.33	6.76	---
HOODS	METAL	MHOODxx	1.25	1.25	1.30	1.30	---	---
	GREY	HOODxx	65	65	---	65	.75	.95

ORDERING INSTRUCTIONS: INSERT THE NUMBER OF CONTACTS IN THE POSITION MARKED 'xx' OF THE 'ORDER BY' PART NUMBER LISTED  
EXAMPLE: A 15 PIN RIGHT ANGLE MALE PC SOLDER WOULD BE DB15PR  
MOUNTING HARDWARE \$1.00

LED DISPLAYS			
FND-357(359)	COM CATHODE	362"	1.25
FND-500(503)	COM CATHODE	5"	1.49
FND-507(510)	COM ANODE	5"	1.49
MAN-72	COM CATHODE	3"	.99
MAN-74	COM CATHODE	3"	.99</

# 20MB HARD DISK SYSTEM ONLY \$389.95!

## BARGAIN HUNTERS CORNER ATTENTION PC USERS!

### 10 MB HARD DISK SYSTEM \$349

- \* SHOCK MOUNTED FOR 80 Gs— IDEAL FOR PORTABLES!
- \* MMI MODEL MM212 1/2 HEIGHT, 75ms ACCESS
- \* INCLUDES CONTROLLER, CABLES & INSTRUCTIONS FOR IBM

### WIRELESS KEYBOARD \$129

- \* MADE BY CHERRY FOR IBM PC & PCjr
- \* OPERATES UP TO 40 FEET FROM COMPUTER
- \* INFRARED RECEIVER FOR PC/XT INCLUDED

HURRY—QUANTITIES ARE LIMITED!  
SPECIALS END 8/31/86

### PAGE WIRE WRAP WIRE PRECUT ASSORTMENT IN ASSORTED COLORS \$27.50

100ea: 5.5", 6.0", 6.5", 7.0"  
250ea: 2.5", 4.5", 5.0"  
500ea: 3.0", 3.5", 4.0"

#### SPOOLS

100 feet \$4.30 250 feet \$7.25  
500 feet \$13.25 1000 feet \$21.95

Please specify color:  
Blue, Black, Yellow or Red

### EMI FILTER \$4.95

- \* MANUFACTURED BY CORCOM
- \* LOW COST
- \* FITS LC-HP BELOW
- \* 6 AMP 120/240 VOLT



### 6 FOOT LINE CORDS

LC-2 2 CONDUCTOR 39  
LC-3 3 CONDUCTOR 99  
LC-HP 3 CONDUCTOR W STD FEMALE SOCKET 1.49

### MUFFIN FANS

3.15" SQ ROTRON 14.95  
3.63" SQ ETRI 14.95  
3.18" SQ MASUSHITA 16.95

### WIRE WRAP PROTOTYPE CARDS FR-4 EPOXY GLASS LAMINATE WITH GOLD-PLATED EDGE-CARD FINERS

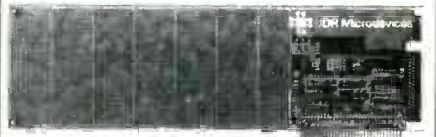

IBM-PR2

#### IBM

BOTH CARDS HAVE SILK SCREENED LEGENDS AND INCLUDES MOUNTING BRACKET

IBM-PR1 WITH .5V AND GROUND PLANE \$27.95  
IBM-PR2 AS ABOVE WITH DECODING LAYOUT \$29.95

#### S-100

P100-1 BARE - NO FOIL PADS \$15.15  
P100-2 HORIZONTAL BUS \$21.80  
P100-3 VERTICAL BUS \$21.80  
P100-4 SINGLE FOIL PADS PER HOLE \$22.75

#### APPLE

P500-1 BARE - NO FOIL PADS \$15.15  
P500-3 HORIZONTAL BUS \$22.75  
P500-4 SINGLE FOIL PADS PER HOLE \$21.80  
7060-45 FOR APPLE IIe AUX SLOT \$30.00

### SOCKET-WRAP I.D.™

- \* SLIPS OVER WIRE WRAP PINS
  - \* IDENTIFIES PIN NUMBERS ON WRAP SIDE OF BOARD
  - \* CAN WRITE ON PLASTIC, SUCH AS IC #
- | PINS | PART#     | PCK. OF | PRICE |
|------|-----------|---------|-------|
| 8    | IDWRAP 08 | 10      | 1.95  |
| 14   | IDWRAP 14 | 10      | 1.95  |
| 16   | IDWRAP 16 | 10      | 1.95  |
| 18   | IDWRAP 18 | 5       | 1.95  |
| 20   | IDWRAP 20 | 5       | 1.95  |
| 22   | IDWRAP 22 | 5       | 1.95  |
| 24   | IDWRAP 24 | 5       | 1.95  |
| 28   | IDWRAP 28 | 5       | 1.95  |
| 40   | IDWRAP 40 | 5       | 1.95  |
- PLEASE ORDER BY NUMBER OF PACKAGES (PCK. OF)

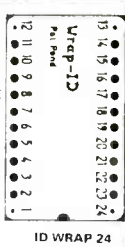

### FRAME STYLE TRANSFORMERS

12.6V AC CT 2 AMP 5.95  
12.6V AC CT 4 AMP 7.95  
12.6V AC CT 8 AMP 10.95  
25.2V AC CT 2 AMP 7.95

### 25 PIN D-SUB GENDER CHANGERS \$7.95



### SWITCHING POWER SUPPLIES

#### PS-IBM \$69.95

- \* FOR IBM PC-XT COMPATIBLE
- \* 135 WATTS
- \* .5V @ 15A, .12V @ 4.2A
- \* .5V @ 5A, .12V @ 5A
- \* ONE YEAR WARRANTY



#### PS-IBM-150 \$79.95

- \* FOR IBM PC-XT COMPATIBLE
- \* 150 WATTS
- \* .12V @ 5.2A, .5V @ 16A
- \* .12V @ 5A, .5V @ 5A
- \* ONE YEAR WARRANTY



#### PS-130 \$99.95

- \* 130 WATTS
- \* SWITCH ON REAR
- \* FOR USE IN OTHER IBM TYPE MACHINES
- \* 90 DAY WARRANTY



#### PS-A \$49.95

- \* USE TO POWER APPLE TYPE SYSTEMS
- \* .5V @ 4A, .12V @ 2.5A
- \* .5V @ 5A, .12V @ 5A
- \* APPLE POWER CONNECTOR



#### PS-SPL200 \$49.95

- \* .5V @ 25A, .12V @ 3.5A
- \* .5V @ 1A, .12V @ 1A
- \* UL APPROVED
- \* ALUMINUM ENCLOSURE



### CAPACITORS

TANTALUM			
1.0µf	15V	35	47µf 35V .45
6.8	15V	70	1.0 35V .45
10	15V	80	2.2 35V .65
22	15V	1.35	4.7 35V .85
22	35V	40	10 35V 1.00

DISC			
10µf	50V	05	680 50V .05
22	50V	05	00122 50V .05
27	50V	05	0022 50V .05
33	50V	05	005 50V .05
47	50V	05	01 50V .07
68	50V	05	02 50V .07
100	50V	05	05 50V .07
220	50V	05	1 12V .10
560	50V	05	1 50V .12

MONOLITHIC			
01µf	50V	14	1µf 50V .18
047µf	50V	15	47µf 50V .25

ELECTROLYTIC			
RADIAL		AXIAL	
1µf	25V	14	1µf 50V .14
2.2	35V	15	10 50V .15
4.7	50V	15	22 16V .14
10	50V	15	47 50V .20
47	35V	18	100 35V .25
100	16V	18	220 25V .30
220	35V	20	470 50V .50
470	25V	30	1000 16V .60
2200	16V	70	2200 16V .70
4700	25V	1.45	4700 16V 1.25

### DATASE EPROM ERASER \$34.95

- \* ERASES 2 IN 10 MINUTES
- \* COMPACT-NO DRAWER
- \* THIN METAL SHUTTER PREVENTS UV LIGHT FROM ESCAPING



### 1/4 WATT RESISTORS

5% CARBON FILM ALL STANDARD VALUES FROM 1 OHM TO 10 MEG. OHM

10 PCS same value	05	100 PCS same value	02
50 PCS same value	.025	1000 PCS same value	015

### RESISTOR NETWORKS

SIP 10 PIN	9 RESISTOR	.69
SIP 8 PIN	7 RESISTOR	.59
DIP 16 PIN	8 RESISTOR	1.09
DIP 16 PIN	15 RESISTOR	1.09
DIP 14 PIN	7 RESISTOR	.99
DIP 14 PIN	13 RESISTOR	.99

### SPECIALS ON BYPASS CAPACITORS

.01 µf CERAMIC DISC	100/\$5.00
.01 µf MONOLITHIC	100/\$10.00
.1 µf CERAMIC DISC	100/\$6.50
.1 µf MONOLITHIC	100/\$12.50

### WISH SOLDERLESS BREADBOARDS

PART NUMBER	DIMENSIONS	DISTRIBUTION STRIP(S)	TIE POINTS	TERMINAL STRIP(S)	TIE POINTS	BINDING POSTS	PRICE
WBU-D	38 x 6.50"	1	100	---	---	---	2.95
WBU-T	1.38 x 6.50"	---	---	1	630	---	6.95
WBU-204-3	3.94 x 8.45"	1	100	2	1260	2	17.95
WBU-204	5.13 x 8.45"	4	400	2	1260	3	24.95
WBU-206	6.88 x 9.06"	5	500	3	1890	4	29.95
WBU-208	8.25 x 9.45"	7	700	4	2520	4	39.95



### LITHIUM BATTERY AS USED IN CLOCK CIRCUITS

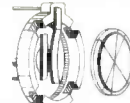

3 VOLT BATTERY \$3.95  
BATTERY HOLDER \$1.49

### NEW EDITION! 1986 IC MASTER

THE INDUSTRY STANDARD  
\$129.95

VISIT OUR RETAIL STORE LOCATED AT 1256 SOUTH BASCOM AVENUE IN SAN JOSE

**JDR Microdevices**  
1224 S. Bascom Avenue, San Jose, CA 95128

Toll Free 800-538-5000 • (408) 995-5430

FAX (408) 275-8415 • Telex 171-110

© COPYRIGHT 1986 JDR MICRODEVICES

THE JDR MICRODEVICES LOGO IS A REGISTERED TRADEMARK OF JDR MICRODEVICES. JDR INSTRUMENTS AND JDR MICRODEVICES ARE TRADEMARKS OF JDR MICRODEVICES. IBM IS A TRADEMARK OF INTERNATIONAL BUSINESS MACHINES. APPLE IS A TRADEMARK OF APPLE COMPUTER.

HOURS: M-W-F, 9-6 TU-TH, 9-9 SAT, 9-5

PLEASE USE YOUR CUSTOMER NUMBER WHEN ORDERING

TERMS: Minimum order \$10.00. For shipping and handling include \$2.50 for UPS Ground and \$3.50 for UPS Air. Orders over 1 lb. and foreign orders may require additional shipping charges—please contact our sales department for the amount. CA residents must include applicable sales tax. All merchandise is warranted for 90 days unless otherwise stated. Prices are subject to change without notice. We are not responsible for typographical errors. We reserve the right to limit quantities and to substitute manufacturer. All merchandise subject to prior sale.

# 20MB HARD DISK SYSTEM ONLY \$389.95!

## DISK DRIVES FOR APPLE COMPUTERS

**AP-150**  
**\$99.95**

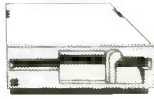

- 1/2 HT. DIRECT DRIVE
- 100% APPLE COMPATIBLE
- SIX MONTH WARRANTY

**BAL-500**  
**\$129.95**



- TEAC MECHANISM-DIRECT DRIVE
- 100% APPLE COMPATIBLE
- FULL ONE YEAR WARRANTY

**AP-135**  
**\$129.95**

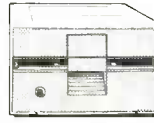

- FULL HT SHUGART MECHANISM
- DIRECT REPLACEMENT FOR APPLE DISK II
- SIX MONTH WARRANTY

**DOUBLE SIDED!**

**MAC535**  
**\$249.95**



- 3.5" ADD-ON DISK DRIVE
- 100% MACINTOSH COMPATIBLE
- DOUBLE SIDED 800K BYTE STORAGE
- HIGH RELIABILITY DRIVE
- HAS AUTO-EJECT MECHANISM
- FULL ONE YEAR WARRANTY

**AD-3C**  
**\$139.95**

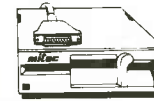

- 100% APPLE IIc COMPATIBLE. READY TO PLUG IN. W/SHIELDED CABLE & MOLDED 19 PIN CONNECTOR
- FAST, RELIABLE SLIMLINE DIRECT DRIVE
- SIX MONTH WARRANTY

### DISK DRIVE ACCESSORIES

- FDD CONTROLLER CARD \$49.95
- IIc ADAPTOR CABLE \$19.95
- ADAPTS STANDARD APPLE DRIVES FOR USE WITH APPLE IIc

**KB-1000** **\$79.95**

- CASE WITH KEYBOARD FOR APPLE TYPE MOTHERBOARD
- USER DEFINED FUNCTION KEYS
  - NUMERIC KEYPAD WITH CURSOR CONTROL
  - CAPS LOCK - AUTO-REPEAT

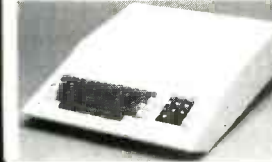

**KEYBOARD-AP** **\$49.95**

- REPLACEMENT FOR APPLE II KEYBOARD
- CAPS LOCK KEY, AUTO-REPEAT
- ONE KEY ENTRY OF BASIC OR CP/M COMMANDS



### EXTENDER CARDS

IBM-PC	\$45.00
IBM-AT	\$68.00
APPLE II	\$45.00
APPLE IIc	\$45.00
MULTIBUS	\$86.00

## APPLE COMPATIBLE INTERFACE CARDS

**EPROM PROGRAMMER \$59.95**

**MODEL RP525**



- DUPLICATE OR BURN ANY STANDARD 27xx SERIES EPROM
- EASY TO USE MENU DRIVEN SOFTWARE IS INCLUDED
- MENU SELECTION FOR 2716, 2732, 2732A, 2764 AND 27128
- HIGH SPEED WRITE ALGORITHM
- LED INDICATORS FOR ACTIVITY
- NO EXTERNAL POWER SUPPLY NEEDED
- ONE YEAR WARRANTY

**16K RAMCARD \$39.95**



- FULL TWO YEAR WARRANTY
- EXPAND YOUR 48K APPLE TO 64K
- USE IN PLACE OF APPLE LANGUAGE CARD

**BARE PC CARD W/INSTRUCTIONS \$9.95**

**IC TEST CARD \$99.95**



- QUICKLY TESTS MANY COMMON ICs
- DISPLAYS PASS OR FAIL
- ONE YEAR WARRANTY
- TESTS: 4000 SERIES CMOS, 74HC SERIES CMOS, 7400, 74LS, 74L, 74H & 74S

**300B MODEM \$49.95**

FOR APPLE OR IBM  
INCLUDES ASCII PRO-EZ SOFTWARE

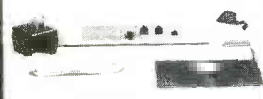

- FCC APPROVED
  - BELL SYSTEMS 103 COMPATIBLE
  - INCLUDES AC ADAPTOR
  - AUTO-DIAL
  - DIRECT CONNECT
- CABLE FOR APPLE IIc \$14.95**

**JOYSTICK CR-401 \$7.95**

FOR ATARI 400, 800, 2600,  
VIC 20/64 AND APPLE IIc

### DISKFILE

HOLDS 70 5 1/4" DISKETTES

**\$895**



**3.5" DISKFILE HOLDS 40 \$965**

### POWER STRIP

- UL APPROVED
- 15A CIRCUIT BREAKER



## BAL 3-WAY SWITCH BOXES

- SERIAL OR PARALLEL
- CONNECTS 3 PRINTERS TO ONE COMPUTER OR VICE VERSA
- ALL LINES SWITCHES
- HIGH QUALITY ROTARY SWITCH MOUNTED ON PCB
- GOLD CONTACTS
- STURDY METAL ENCLOSURE



**SWITCH-3P CENTRONICS PARALLEL \$99.95**

**SWITCH-3S RS232 SERIAL \$99.95**

## BAL PRINTER BUFFERS

- FREES COMPUTER FOR OTHER TASKS WHILE PRINTING LONG DOCUMENTS
- STAND-ALONE DESIGN, WORKS WITH ANY COMPUTER OR PRINTER
- ALL MODELS FEATURE PRINT PAUSE MEMORY CHECK, GRAPHICS CAPABILITY

**SP120P PARALLEL \$139.95**

- 64K UPGRADABLE TO 256K
- LED INDICATOR SHOWS VOLUME OF DATA IN BUFFER

**SP120S RS232 SERIAL \$159.95**

- 64K UPGRADABLE TO 256K
- 6 SELECTABLE BAUD RATES, FROM 600B-19,200B

**SP110P PARALLEL \$249.95**

- 64K UPGRADABLE TO 512K
- SPOOLS OUTPUT OF UP TO 3 COMPUTERS
- LED BARGRAPH DISPLAYS AMOUNT OF DATA IN BUFFER
- RESET FUNCTION CLEARS DATA IN BUFFER
- REPEAT FUNCTION CAN PRODUCE MULTIPLE COPIES OF A DOCUMENT



SP120

SP110

## NASHUA DISKETTES DEALS

5 1/4" SOFT SECTOR  
DS/DD WITH HUB RINGS

**\$990** **69c<sup>ea</sup>** **59c<sup>ea</sup>**  
BOX OF 10 BULK QTY 50 BULK QTY 250

NASHUA DISKETTES WERE JUDGED TO HAVE THE HIGHEST POLISH AND RECORDED AMPLITUDE OF ANY DISKETTES TESTED ACCORDING TO "COMPARING FLOPPY DISKS", BYTE 9/84

### DISKETTES NASHUA 5 1/4"

N-MD2D	DS/DD SOFT	\$9.90
N-MD2F	DS/QUAD SOFT	\$34.95
N-MD2H	DS/HD FOR AT	\$49.95

### NASHUA 8"

N-FD1	SS/DD SOFT	\$27.95
N-FD2D	DS/DD SOFT	\$34.95

### NASHUA 3.5"

N-3.5SS	3.5" SS/DD FOR MAC	\$32.95
---------	--------------------	---------

### VERBATIM 5 1/4"

V-MD1D	SS/DD SOFT	\$23.95
V-MD2D	DS/DD SOFT	\$29.95
V-MD110D	SS/DD 10 SECTOR HARD	\$23.95

## Sakata 120 CPS DOT MATRIX PRINTER



**MODEL SP-1200 \$169.95**

- EPSON/IBM COMPATIBLE
- 9-WIRE PRINTHEAD
- 120 CPS-BIDIRECTIONAL, 80 COL.
- FRICTION AND TRACTOR FEED
- PROPORTIONAL SPACING
- CENTRONICS PARALLEL INTERFACE
- 8 CHARACTER SETS AND GRAPHICS

6 FOOT IBM PRINTER CABLE \$9.95  
REPLACEMENT RIBBON CARTRIDGE \$11.95

## 5 1/4" FLOPPY DISK DRIVES

TEAC FD-55B 1/2 HT DS/DD (FOR IBM)	\$109.95
TEAC FD-55F 1/2 HT DS/QUAD (FOR IBM)	\$124.95
TEAC FD-55G 1/2 HT DS/HD (FOR IBM AT)	\$154.95
TANDON TM100-2 DS/DD (FOR IBM)	\$119.00
TANDON TM50-2 1/2 HT DS/DD (FOR IBM)	\$79.95
MPI-852 DS/DD (FOR IBM)	\$79.95
QUME QT-142 1/2 HT DS/DD (FOR IBM)	\$79.95

## 8" FLOPPY DISK DRIVES

FD 100-8 SS/DD (SA/801 EQUIV)	\$119.00
FD 200-8 DS/DD (SA/851R EQUIV)	\$159.00

## DISK DRIVE ACCESSORIES

TEAC SPECIFICATION MANUAL	\$5.00
TEAC MAINTENANCE MANUAL	\$25.00
1/2 HT MOUNTING HARDWARE	\$2.95
MOUNTING RAILS FOR IBM AT	\$4.95
"Y" POWER CABLE FOR 5 1/4" FDDs	\$2.95
5 1/4" FDD POWER CONNECTORS	\$1.19



TEAC FD-55

TANDON TM100-2

## DISK DRIVE ENCLOSURES

**CAB-APPLE \$24.95**  
APPLE TYPE CABINET W/OUT POWER SUPPLY

**CAB-1FH5 \$69.95**  
FULL HT 5 1/4" BEIGE CABINET W/POWER SUPPLY

**CAB-2SV5 \$49.95**  
DUAL SLIMLINE 5 1/4" CABINET W/POWER SUPPLY

**CAB-2SV8 \$209.95**  
DUAL SLIMLINE 8" CABINET W/POWER SUPPLY

**CAB-2FH8 \$219.95**  
DUAL FULL HT 8" CABINET W/POWER SUPPLY



CAB-2SV5

CAB-1FH5

## TEST EQUIPMENT FROM JDR INSTRUMENTS

**DIGITAL MULTIMETER PEN DPM-1000**  
AUTO RANGING, POLARITY AND DECIMAL!

**\$54.95**

- LARGE 3.5 DIGIT DISPLAY
- DATA HOLD SWITCH FREEZES READING
- FAST, AUDIBLE CONTINUITY TEST
- LOW BATTERY INDICATOR
- OVERLOAD PROTECTION



**20MHZ DUAL TRACE OSCILLOSCOPE MODEL 2000 \$389.00**

**35MHZ DUAL TRACE OSCILLOSCOPE MODEL 3500 \$549.00**

FOR MORE INFORMATION ON THE OSCILLOSCOPES, CALL US FOR FREE PRODUCT BRIEFS.

CALL FOR VOLUME QUOTES © COPYRIGHT 1986 JDR MICRODEVICES

CIRCLE 179 ON FREE INFORMATION CARD

www.americanradiohistory.com

# 20 MEGA BYTE HARD DISK SYSTEM

# ONLY \$389.95!

## SEAGATE ST-225 20 MB HARD DISK SYSTEM

INCLUDES HALF LENGTH HD CONTROLLER, CABLES, MOUNTING HARDWARE AND INSTRUCTIONS. ALL DRIVES ARE PRE-TESTED AND COME WITH A ONE YEAR WARRANTY.

# \$389.95

## XT COMPATIBLE MOTHERBOARD

# \$129.95

- 4.77 MHz 8088 CPU, OPTIONAL 8087 CO-PROCESSOR
- 8 EXPANSION SLOTS
- 0K RAM INSTALLED, EXPANDABLE TO 640K ON-BOARD MEMORY
- ALL ICs SOCKETED-HIGHEST QUALITY PC BOARD
- ACCEPTS 2764 OR 27128 ROMS

**PRO-BIOS \$19.95**

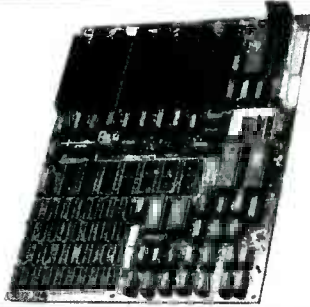

## IBM COMPATIBLE INTERFACE CARDS

ALL WITH A ONE YEAR WARRANTY

### MULTI I/O FLOPPY CARD \$89.95

PERFECT FOR THE 640K MOTHERBOARD



- 2 DRIVE FLOPPY DISK CONTROLLER
- 1 RS232 SERIAL PORT, OPTIONAL 2nd SERIAL PORT
- PARALLEL PRINTER PORT
- GAME PORT
- CLOCK/CALENDAR
- SOFTWARE: CLOCK UTILITIES, RAMDISK, SPOOLER
- OPTIONAL SERIAL PORT \$15.95

### MULTIFUNCTION CARD \$84.95

ALL THE FEATURES OF AST'S 6 PACK PLUS AT HALF THE PRICE



- CLOCK/CALENDAR
- 0-384K RAM
- SERIAL PORT
- PARALLEL PORT
- GAME PORT
- SOFTWARE INCLUDED: PRINTER CABLE \$9.95, 64K RAM UPGRADE \$11.61

### COLOR GRAPHICS ADAPTOR \$69.95

FULLY COMPATIBLE WITH IBM COLOR CARD



- 4 VIDEO INTERFACES: RGB, COMPOSITE COLOR, HI-RES COMPOSITE MONOCHROME, CONNECTOR FOR RF MODULATOR
- COLOR GRAPHICS MODE: 320 x 200
- MONO GRAPHICS MODE: 640 x 200
- LIGHT PEN INTERFACE

### MONOCHROME GRAPHICS CARD \$89.95

FULLY COMPATIBLE WITH IBM MONOCHROME ADAPTOR & HERCULES GRAPHICS



- LOTUS COMPATIBLE
- TEXT MODE: 80 x 25
- GRAPHICS MODE: 720 x 348
- PARALLEL PRINTER INTERFACE
- OPTIONAL SERIAL PORT \$19.95

### MONOCHROME ADAPTOR \$49.95

ANOTHER FANTASTIC VALUE FROM JDR!

- IBM COMPATIBLE TTL OUTPUT
  - 720 x 350 PIXEL DISPLAY
- PLEASE NOTE: THIS CARD WILL NOT RUN LOTUS GRAPHICS AND DOES NOT INCLUDE A PARALLEL PORT

### FLOPPY DISK DRIVE ADAPTOR \$34.95



- INTERFACES UP TO 4 STANDARD FDDs TO IBM PC OR COMPATIBLES
- INCLUDES CABLE FOR TWO INTERNAL DRIVES
- STANDARD DB37 FOR EXTERNAL DRIVES
- RUNS QUAD DENSITY DRIVES WHEN USED WITH JFORMAT

## 1200 BAUD MODEMS

HAYES COMPATIBLE, AUTO-DIAL, AUTO-ANSWER, AUTO RE-DIAL ON BUSY, POWER-UP SELF TEST, FULL ONE YEAR WARRANTY

### MODEL 1200B\*

- INTERNAL DESIGN
- 10 INCH CARD
- SERIAL PORT INCLUDED

**\$169.95**

\*FOR IBM, INCLUDES PC TALK III COMMUNICATIONS SOFTWARE

### MODEL 1200H\*

- INTERNAL DESIGN
- HALF LENGTH (5") CARD
- INCLUDES SPEAKER

**\$149.95**

### SMARTTEAM

- EXTERNAL DESIGN
- WITH POWER SUPPLY
- LED STATUS INDICATORS

**\$169.95**

## CRT MONITORS FOR ALL APPLICATIONS



**LUXOR HI-RES RGB MONITOR**  
MODEL 190-9528

- DIGITAL RGB-IBM COMPATIBLE
- 14" SCREEN
- 16 TRUE COLORS
- 25 MHz BANDWIDTH
- RESOLUTION > 640 x 262
- 31mm DOT PITCH
- CABLE FOR IBM PC INCLUDED

**\$299.95**



**SAKATA COMPOSITE COLOR**  
MODEL SC-100

- TOP RATED FOR APPLE
- 13" COMPOSITE VIDEO
- RESOLUTION 280H x 300V
- INTERNAL AUDIO AMP
- ONE YEAR WARRANTY

**\$169.95**



**CENTER SYSTEMS MONOCHROME**  
MODEL KLM-1211

- IBM COMPATIBLE TTL INPUT
- 12" NON-GLARE SCREEN
- P39 GREEN PHOSPHORUS
- VERY HIGH RESOLUTION: 25 MHz BANDWIDTH 1100 LINES (CENTER)

AMBER VERSION \$108.95  
**\$99.95**

## BUILD YOUR OWN 256K XT COMPATIBLE SYSTEM

- XT MOTHERBOARD \$129.95
- PRO-BIOS \$19.95
- 256K RAM \$26.55
- 130 WATT POWER SUPPLY \$89.95
- FLIP-TOP CASE \$39.95
- DKM-2000 KEYBOARD \$59.95
- 1/2 HEIGHT QUME DRIVE \$79.95
- FLOPPY DISK CONTROLLER \$34.95
- MONOCHROME ADAPTOR \$49.95
- MONOCHROME MONITOR \$89.95

**TOTAL: \$611.10**

### MONITOR STAND



TILTS AND SWIVELS

**ONLY \$12.95**

### IBM PRINTER CABLE



• DB25 TO CENTRONICS  
• SHIELDED CABLE **\$9.95**

## IBM STYLE COMPUTER CASE

AN ATTRACTIVE STEEL CASE WITH A HINGED LID FITS THE POPULAR PC/XT COMPATIBLE MOTHERBOARDS

- SWITCH CUT-OUT ON SIDE FOR PC/XT STYLE POWER SUPPLY
- CUT-OUT FOR 8 EXPANSION SLOTS
- ALL HARDWARE INCLUDED

**\$39.95**

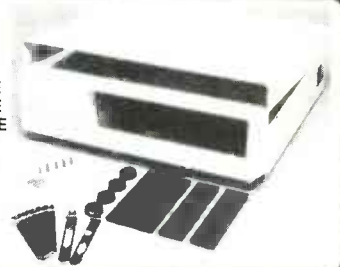

## IBM COMPATIBLE KEYBOARDS

DKM-2000 \$59.95

IBM-5151 \$79.95

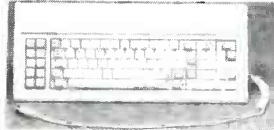

- "5150" STYLE KEYBOARD
- FULLY IBM COMPATIBLE
- LED STATUS INDICATORS FOR CAPS & NUMBER LOCK
- 83 KEY - SAME LAYOUT AS IBM PC/XT KEYBOARD



- REPLACEMENT FOR KEYTRONICS KB-5151™
- SEPARATE CURSOR & NUMERIC KEYPAD
- CAPS LOCK & NUMBER LOCK INDICATORS
- IMPROVED KEYBOARD LAYOUT

## POWER SUPPLY



**NOW ONLY \$69.95**

- FOR IBM PC-XT COMPATIBLE
- 135 WATTS
- +5V @ 15A, +12V @ 4.2A
- -5V @ .5A, -12V @ .5A

**150 WATT MODEL \$79.95**

## DISK DRIVES TANDON TM50-2

# \$79.95

- 1/2 HT DS/DD
- IBM COMPATIBLE
- EXTREMELY QUIET!

TEAC FD-55B	DS/DD	\$109.95
TEAC FD-55F	DS/QUAD	\$124.95
TEAC FD-55B	DS/HD	\$154.95
QUME QT-142	DS/DD	\$79.95
MOUNTING HARDWARE		\$2.95
AT/RAILS		\$4.95

**JDR Microdevices**

1224 S. Bascom Avenue, San Jose, CA 95128

Toll Free 800-538-5000 • (408) 995-5430 • FAX (408) 275-8415 • Telex 171-110

CIRCLE 180 ON FREE INFORMATION CARD

© COPYRIGHT 1986 JDR MICRODEVICES

www.americanradiohistory.com

# TENMA

**THE NAME YOU CAN TRUST IN ELECTRONIC TEST EQUIPMENT**

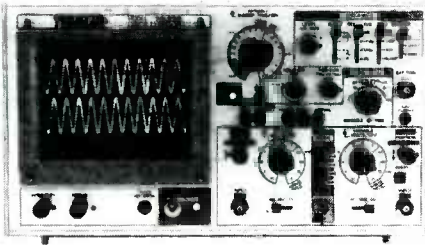

### TENMA 35MHz Dual Trace Oscilloscope

- Two high quality 10:1 probes included
- For additional specification see MCM Catalog #12

#72-330  
**\$569<sup>95</sup>**  
(ea.)

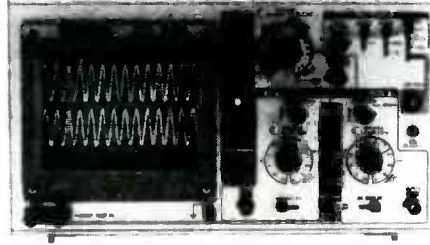

### TENMA 20MHz Dual Trace Oscilloscope

- Two high quality 10:1 probes included
- For additional specification see MCM Catalog #12

#72-320  
**\$389<sup>95</sup>**  
(ea.)

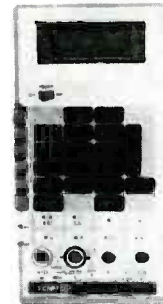

### TENMA 3 1/2 Digit LCD Multimeter

- Measures resistance, AC-DC voltage and current
- Diode and hFE transistor tests
- Overload protection
- 10Mohm input impedance
- Carrying case included

#72-050  
**\$398<sup>0</sup>**  
(ea.)



### TENMA 30A Power Supply

- Output voltage: 1-15VDC
- Lighted cross needle meter
- Displays voltage, current and power simultaneously
- Output current: 30A, 22A continuous
- Fan cooled

#72-035  
**\$199<sup>00</sup>**  
(ea.)



**NEW**

### TENMA 0-18V 3A Power Supply

- Regulated outputs — constant volt or constant current, both are continuously variable
- Can be connected in series or parallel for more voltage or current output
- Reverse polarity and overload protected
- Isolated output

#72-420  
**\$99<sup>50</sup>**  
(ea.)

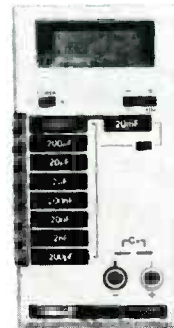

### TENMA Digital Capacitance Meter

- Measurement range from 0.1pF to 19,999µF
- Sampling time: .5 seconds
- Accuracy: ± 1% full scale
- Checks capacitors in or out of circuit
- Carrying case included

#72-040  
**\$59<sup>80</sup>**  
(ea.)

**\$54<sup>95</sup>**  
(2-up)

### TENMA Combination Function Generator and Frequency Counter

- 6 digit display
- Output range: 2Hz-2MHz: seven ranges
- Counter range: .1Hz-10MHz
- 5-15V TTL and CMOS output
- Wave forms: sine, triangle, square, pulse, and ramp.

#72-380  
**\$219<sup>90</sup>**  
(ea.)



**NEW**

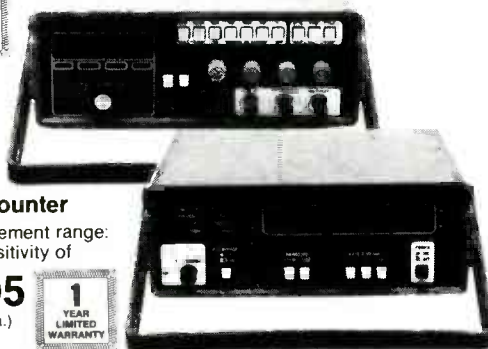

### TENMA Frequency Counter

- 8 digit LED display
- Measurement range: 1Hz-120MHz
- High input sensitivity of 20mV RMS

#72-375  
**\$189<sup>95</sup>**  
(ea.)



**NEW**

**MCM ELECTRONICS**  
858 E. Congress Park Dr.  
Centerville, Ohio 45459-4072  
(513) 434-0031

SOURCE NO. RE-24

- Terms:**
- \$10 minimum order \$1.00 charge for orders under \$10.
  - \$20 minimum charge card order.
  - Orders shipped UPS C.O.D.
  - Most orders shipped within 24 hours.
  - Sales office open 8:30 am to 7:00 pm Saturdays 10:00 am to 3 pm EST.
  - For prepaid orders add \$2.75 for shipping and handling.
  - Should shipping and handling charges exceed \$2.75, the balance due will be sent C.O.D.



**Be Sure To Call For Your FREE Catalog! Over 6,000 Items!**

We also have ... a full line of test equipment, computer accessories, telephone accessories, speakers, television parts, flybacks, yokes, switches, fuses, lamps, capacitors, resistors, cartridges, styli, wire, CATV equipment, the largest selection of original Japanese semiconductors in the country and more.

**CALL TOLL FREE 1-800-543-4330**  
In Ohio 1-800-762-4315 • In Alaska and Hawaii 1-800-858-1849

CIRCLE 87 ON FREE INFORMATION CARD

# Build it yourself!

It's Dick Smith Electronics for the latest & best in kits!

The wait is over! Our newest transceiver kit is now in stock

HF Transceiver Kit \$229 Cat K-6330



**NEW!**

**SPECIFICATIONS**  
 Frequency Range: any 500 kHz range within 2.30 MHz  
 Transmission Modes: USB, CW  
 Supply Voltage: 12.5V DC  
 Current Drain: 4.5A on transmit  
 Frequency Resolution: 100Hz  
 Modality: 100% L - 100% (after warm-up)  
 Crystal: 10.7 MHz (10.7015) MHz  
**TRANSMITTER**  
 Power Output: 30W PEP (15W CW)  
 Occupied Bandwidth: 8kHz (2.5kHz)  
 Harmonic Suppression: Better than 60dB

Electronics Australia said: "For the keen amateur it represents an ideal opportunity to build a really worthwhile piece of gear. Despite the relative circuit complexity construction is straight forward & alignment a breeze. (Oct 85) Now released in the U.S.A., this state-of-the-art design is supplied in the 80 meter version, but it can (with modification) cover any single 500 kHz segment within 2.30 MHz (call or write for release dates of band upgrade kits shown below). This kit is easy to build and includes all hardware, leads, mounting bracket, mic, & our 14 day satisfaction guarantee!"

## Remote Control at your Fingertips!

Don't get out of bed to turn off the TV! Don't stumble in the dark looking for the lamp. Build these Infra-Red Transmitter/Receiver kits instead!

This project puts you back in convenience! The transmitter fits in a matchbox-sized case with clip for belt or pocket (why not get several for the family)? It sends out a short burst of high energy infra-red light or pulses (why not get several for the family)? It sends out a short burst of high energy infra-red light or pulses (why not get several for the family)? It sends out a short burst of high energy infra-red light or pulses (why not get several for the family)?

Receiver WITH CASE \$32 Cat K-3428  
 Transmitter WITH CASE \$7.95 Cat K-3429  
 Battery for Transmitter (not incl) \$3.35 \$4.19



## Featured in June, July, & Aug Radio Electronics

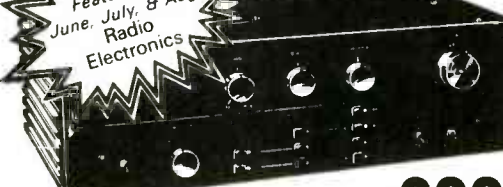

Radio Direction Finder Kit \$99 Cat K-6345

- 12V or 50-500 MHz range
- 170 calibration
- Adjustable internal mono speaker
- Stable digital circuitry
- Self-aligning commutating filters

Featured in 73 for Radio Amateurs

## Available Soon! Transceiver Band Upgrade Packs

Cat K-6331 40m/7.0-7.5 MHz \$14.95 EACH  
 Cat K-6332 20m/14.0-14.5 MHz  
 Cat K-6333 15m/21.0-21.5 MHz  
 Cat K-6334 10m/28.0-28.5 MHz

## Build Your Own 200W Mosfet Stereo Amp!

An Electronics Australia Lab Design

We think this is the best build-it-yourself design available! Feature for feature, dollar for dollar, the Playmaster blows the "big names" (with the big prices) away. Electronics input circuitry handles moving magnet, moving coil, CD, hi-fi, VCR, cassette, tuner, & more. Soft touch control, dec. thump, and toroidal transformers are only a few of its many features, and the step-by-step instruction manual makes it easy to build! Sorry, Dick, it doesn't work, repair coupon included, but if, after examination, you feel the kit is beyond your skill level, simply return it intact for a full refund!

## Take a Big Byte!



Get the Best of Apple® IIe & IIc at Half the Price!  
 The best features of the IIe & IIc are combined in one high-performance package. 128 K RAM (expandable to 384K); 32K ROM w/ Microsom BASIC; 40/80 col. text; 5 1/4" drive (second drive optional); double hi-res graphics; modern port joystick/mouse interface; supports RGB monitor & LCD displays; And it's expandable; supports RGB monitor & LCD displays; expansion slot for Apple II cards; CP/M socket; optional battery pack for portability. Runs most Apple programs - business, educational, games!

**LASER 128 \$399**  
 Apple Compatible Cat X-6000

## Variable Power Supply Kit

This outstanding kit provides voltages from 1 to 30 volts, full protection, variable current limiting from 0 to 1 amp (with LED to indicate current limit mode). Plus metering of both voltage and current output.

You receive a complete kit of parts including US 117V AC transformer (designed for USA) plus metal case and all hardware right down to the last nut & bolt. A specially prepared silk-screened front panel is included for ease of operation plus it gives your project that professional finish. Good stock available at time of going to press.

Dick Smith Electronics price only \$39.95 for a power supply kit worth much more.

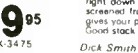

\$39.95 Cat K-3475



Infra-Red Remote Control Kit \$34.95 Cat K-3425

Go wireless! This sleek remote is designed just for K-6335. Requires only a handful of parts easy to build! At this price, it's not an option, it's a necessity!

## Teletext Decoder Kit

Teletext is information & graphics transmitted as digital data between video frames. Get the latest weather, scores, stock prices & more at the touch of a button! All you need is a decoder and ours is a super performer priced to put the competition to shame. Easy to build & requires only a few parts.

● Pre-adjusted/pre-assembled decoder module  
 ● No user fees  
 ● 21 button wired remote

## Build this IBM PC/XT® compatible and SAVE!!

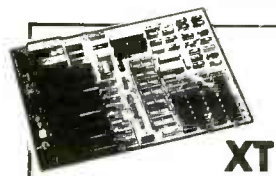

### XT Compatible Motherboard

- 16-bit microprocessor 8088 CPU @ 4.77 MHz
- Optional 8087 socket for coprocessor
- Expandable to 640K
- 8 channel interrupt 8259
- 8 expansion slots
- Same power connector & physical dimensions as IBM PC/XT & Super XT
- Only 54 watt power consumption

\$149 Cat X-1001

BIOS for motherboard \$39.95 Cat X-1000

IBM PC/AT Compatible Motherboard \$899 Cat X-1003

### Multi-function Card

- Fully socketed memory with parity checked, expandable to 384K
- One Parallel Printer Port
- One RS-232C Serial Interface Port
- One Real-Time Clock/Calendar with Battery Backup

\$119.95 Cat X-1005

### Color Graphics Adapter Card

- For use with Color TV frequency & by Composite Signal Monitors or color TV sets
- Supports color and B&W modes
- 40/80 columns x 25 rows
- Graphics mode: 320 x 200 medium/res color; 640 x 200 hi-res black & white

\$89.95 Cat X-1007

### Floppy Disk Drive Adapter

- Drives 2 internal 5 1/4" half height, dsk mini floppy drives
- Supports 2 external floppy disk drives through a 37-pin D connector (optional)
- Double density mem. included
- Write precompensation with phase lock loop data separator

\$44.95 Cat X-1009

### Monochrome Graphics Printer Card

- Fast mode: 80 column x 25 rows
- Graphic mode: 720 x 348 pixels
- Parallel printer port
- Fully compatible with IBM monochrome display/printer and Hercules graphics card

\$119.95 Cat X-1012

### 512K RAM Card

- RAM expansion sockets from 64K to maximum 512K bytes increment
- Memory device: 64K DRAM
- No RAM
- Switch setting hardware: page 64K/64K banks

\$37.95 Cat X-1014

### Multi I/O Card

- One RS-232C Serial Port (secondary serial port optional)
- One Centronics Parallel Port
- Real Time Clock/Calendar with removable Lithium battery backup
- Game Adapter port to connect with IBM compatible joystick
- 5 1/4" disk drive adapter (supports two drives)

\$129.95 Cat X-1016

### Winchester Disk Controller Card

- Controls 2 hard disk drives via ST-506/ST-412 disk interfaces
- Microprocessor based architecture with DMA transfer capability
- On-board disk BIOS ROM with auto boot
- Automatic retries during disk access
- Split mode allows one physical drive to be split into two logical drives

\$174.95 Cat X-1018

## SPECIAL DICK SMITH PACKAGE PRICE!

XT Motherboard	X-1001	\$449.00
BIOS for Motherboard	X-1000	\$39.95
64K Ram	X-1187	\$144.95
Monochrome Graphics Card	X-1012	\$149.95
Floppy Disk Controller	X-1009	\$44.95
130 Watt Power Supply	X-1110	\$89.95
IBM Style Case	X-1120	\$49.95
1/2 Height Disk Drive	X-7506	\$99.95
IBM compatible Mono Monitor	X-1132	\$99.95
84 Keyboard	X-1122	\$79.95

only \$659 Save \$129.55 on individual Prices

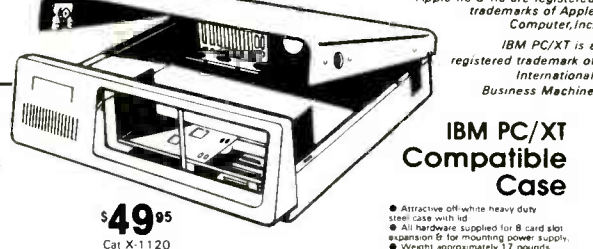

Apple IIe & IIc are registered trademarks of Apple Computer, Inc.  
 IBM PC/XT is a registered trademark of International Business Machine

### IBM PC/XT Compatible Case

- Attractive off-white heavy duty steel case with lid
- All hardware supplied for 8 card slot expansion & for mounting power supply
- Weight approximately 17 pounds.



130W Switching Regulated Power Supply \$89.95 Cat X-1110

- IBM PC/XT compatible
- User selectable 115V/230V AC dual input
- Overload surge & short circuit protection
- Extra low output ripple & noise
- Built-in EMI filter
- 100% burn-in



12" Monochrome Monitors IBM compatible Apple Compatible \$49.95 Cat X-1120

- Separated signals
- 8-pin D-type input
- 1100 lines resolution at center
- 25 MHz (1-380)
- Video amp response
- Composite Video
- RCA Jack input
- 1100 lines resolution at center
- 20MHz (3-380)
- Video amp response

# RADIO ELECTRONICS Reader's Special

SAVE  
**33%**

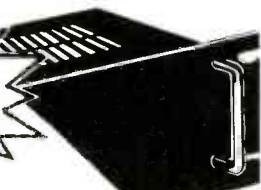

Regularly \$29.95  
**now only \$19.95**  
Cat H-2481  
Valid thru 9/30/86

## 19 inch Rack-Mounting CASE

Professional quality black instrument case of aluminum & steel. Fits standard 19" racks; heavy gauge (1/4") front panel; ventilated top & bottom panels. Supplied flat, assemble in minutes. 16.75" x 9.8" x 5.5"

A special purchase direct from our manufacturer allows us to offer an incredible discount off our usual excellent value!



**ATTENTION BULK BUYERS!**  
Schools! Colleges! Companies!  
Call 415-368-8844  
for special quantity pricing!

### Need other sizes? Try these!



**Slim**  
16.75" x 9.8" x 1.5"  
\$24.95  
Cat H-2483

**Medium**  
16.75" x 9.8" x 3.25"  
\$27.50  
Cat H-2482

### Rack 'em up!

The industry standard 19" rack at an affordable price! Perfect for engineers, designer, musicians, audiophiles - unlimited uses! Outside dimensions: 21.25" wide x 14.25" deep x 36.5" high

**19" Rack \$49.95**  
Cat H-2470

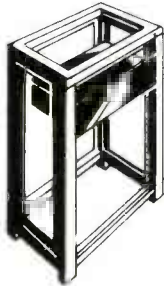

## Get the most in Multimeters!

**MINI:** Great starter unit! II ranges, 2000 ohm/volt. ACV/DCV: 10.50, 250 & 1000. DC current: 0.5, 100mA. Resistance: x10, x1K, 3.6" x 2.4" x 1.2"; 3.6 oz.

**\$7.95**  
Cat Q-1010

**COMPACT:** w. audible continuity test. Diode & fuse protection; 19 ranges plus dB (incl. 10A/DC); 10,000 ohm/volt sensitivity; built-in battery & continuity checkers.

**\$19.95**  
Cat Q-1022

**ECONOMY LCD:** Full overload protection; diode check. DCV: 0.20, 200, 100. ACV: 0.200, 500 (RMS) DC Current 0.2, 2.0, 200mA. RES: 0.2K, 20K, 200K, 2 MEG Ohms.

**\$21.95**  
Cat Q-1440

**MM/LOGIC TESTER:** Diode & fuse protection; built-in logic tester; 20 ranges - DCV: 3.3, 12.60, 300, 1200; ACV: 6.30, 120, 300, 1200. DC: 0.6, 3.0, 300mA RES: x1, x10, x1K, x10K.

**\$24.95**  
Cat Q-1026

**POCKET LCD:** Auto-ranging, 3.5 digit, polarity, indication; 2 times/sec. sampling; low battery indication; 2.2" x 4.25" x .39"

**\$29.95**  
Cat Q-1442

**PUSH-BUTTON LCD:** 16 ranges DCV: 2.2, 20, 200, 1000. ACV: 200, 1000. DC: 200uA, 2.20, 200mA, 10A. RES: 2K, 20K, 200K, 2000K. Diode Check.

**\$39.95**  
Cat Q-1444

**MM/TRANS-CAP CHECKER:** DCV: 0.25, 2.5, 10, 50, 250, 1000 (1000K/V). ACV: 5, 10, 50, 250, 1000 (10K/V). DC: 10mA, 2.5mA, 25mA, 500mA, 10A. AC: 10A, dB: -10 to -62. RES: x1, x10, x1K, x10K. TRANS: Hfe: 0-1000; Ico: 0-50uA. CAP: 50pF-3uF, 0.01 uF-50uF

**\$59.95**  
Cat Q-1140

**AUTO-RANGING LCD:** 17 ranges; memory mode; 3.5 digit display; over-range, low bat. & polarity indication; includes test leads, probes & clips

**\$59.95**  
Cat Q-1515

**3.5 DIGIT LCD:** Super meter with 24 ranges for measuring volts, amps, impedance, current, capacitance, conductance, temperature, transistor test, diode test, & continuity. Great value!

**\$99.95**  
Cat Q-1512

**NEW!**

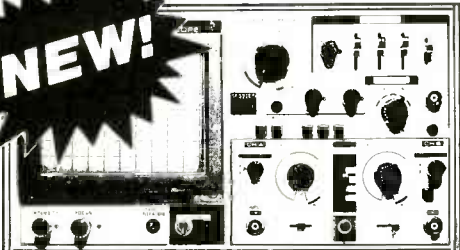

### 5 MHz Single Trace Oscilloscope \$169

- Retrace blanking for clearer display
- 10-mV/division horizontal sensitivity
- Internal or external sync
- Usable response to 5-MHz
- Solid state electronics for fast warm-up/low drift



### 20 MHz Dual Trace Oscilloscope \$329

- Features: packed value; high brightness CRT; special component testing circuit; wide bandwidth; high sensitivity; low power consumption; regulated power supply and more

### 35 MHz Oscilloscope

This instrument has 6KV accelerating voltage for high brightness. The fast sweep time makes this scope suitable for both general purpose & computer use.

**\$529**  
Cat Q-1241

**Source:** INT. CH. CH. & ALL LINE EXT. 1 TO EXT. TV LINE FRAME  
**Scope:** Positive and negative superimposition; variable, with time control  
**Push-In:** AUTO OFF and DC OFF  
**AC HF:** 100, 1K, 10K, 100K, 1M  
**RES:** 100 Ohms  
**CH. A-Y axis:** CH. B-Y axis; vertical sensitivity: 100V/Div.  
**INT. More than 0.3 Div. for DC: 10MHz**  
**More than 1 Div. for DC: 35 MHz**  
**More than 1.5 Div. for DC: 10MHz**  
**More than 1.5 Div. for DC: 10MHz**  
**More than 1000V p-p for DC: 10MHz**  
**More than 0.3 p-p for DC: 35MHz**



### Be the last on your block to Glow in the Dark!

In the wake of the Chernobyl accident, many concerned citizens discovered the value of this affordable, accurate scientific instrument! Used in research, hospitals, etc., this counter is sensitive to a broad range of ionizing radiation, including alpha, beta, gamma & x-rays. Switching range 0.5R/hr-50mR/hr. Includes operating manual.

**\$199** Monitor 4 Geiger Counter  
Cat Q-1000

As seen on TV!

### \$59.95 DIP Meter

Fully functional grid dip oscillator with meter. 6 color coded frequency coils from 1.5 to 250 MHz. Features 2 transistors & 1 diode, approx. 2 KHz sine wave modulation, 1-15 MHz crystal oscillator, 9V DC.

**COMING SOON!**  
Our newest kit - a Closed Caption Decoder for TV sets - See Nov. Radio Electronics for an exciting preview!

### Special Purchase!

Supplies are limited, so take advantage of this superb receiver while supplies last! Check out these features:

- Tuning: all electronic quartz PLL-crystal; 3-speed hr/s manual; continuous; auto-search; direct frequency key-in; 16 station memory; local/dx; 9/10 kHz AM tuning matrix switch ● Frequencies: 1.1 SW bands - 120/90/60/49/41/31/25/24/16/13/11M; AM/FM/LW bands ● Double superfeed for selectivity & image rejection ● Switchable variable pitch BFO for CW & SSB reception ● Tweeter ● RF gain control ● Hi-power amp for 7 woofers/3 tweeters ● Headphone jack ● 12/24hr LCD clock w. alarm ● 110/127/220/240V, 50/60 Hz switchable ● 12VDC or battery operation

**Magnavox \$299.95**  
11 Band World Receiver Cat D-2838

**MAIL ORDERS**  
P.O. Box 8021, Redwood City, CA 94063  
14-Day Money-Back Guarantee

**Visit our Retail Centers!**  
Opening soon in San Francisco!  
Beverly: 2474 Spaulding Ave (415) 386-0755  
Redwood City: 390 Convention Way (415) 368-8844  
San Jose: 1880 Stevens Creek Blvd (408) 241-2266  
Los Angeles: 1830 Westwood Blvd (213) 418-0926  
Head Office: 390 Convention Way Redwood City, CA 94063

We ship UPS Ground unless otherwise requested. Add 5% of order total (\$1.50 min.) for shipping. Outside USA add 20% (\$4 min.). There is an additional \$1.50 handling fee. California residents please add sales tax.

**Order Toll Free 1-800-332-5373**  
Call Monday - Friday 7a.m. - 6p.m. Pacific Time. In California call 415-368-1066

# DICK SMITH ELECTRONICS

EVERYTHING FOR THE ELECTRONICS ENTHUSIAST

### Did you get your FREE CATALOG?

The new 1986/7 DICK SMITH ELECTRONICS catalog is 148 colorful pages packed with thousands of fantastic products, incredible values, and an exclusive 15 page data section. We ship our catalogs first class mail, so you'll get yours with no delay!

Send \$1 for postage & handling to DSE, P.O. Box 2249, Redwood City, CA 94064

Name \_\_\_\_\_  
Address \_\_\_\_\_  
City \_\_\_\_\_ State \_\_\_\_\_ Zip \_\_\_\_\_

# cable tv

## DESCRAMBLER PARTS!

We stock the exact parts, PC board and AC adaptor for Radio Electronics February 1984 article on building your own **Cable TV Descrambler**.

- #701 **PARTS PACKAGE**.....\$29.95  
Includes all the original resistors, capacitors, diodes, transistors, integrated circuits, coils, IF transformers (toko BKAN-K5552AXX).
- #702 **PC BOARD**.....\$12.95  
Original etched & drilled silk-screened PC board used in the article.
- #704 **AC ADAPTOR**.....\$12.95  
Original (14 volts DC @ 285ma) ac adaptor used in the article.

### S □ P □ E □ C □ I □ A □ L □ S

- BOTH #701 & #702..... NOW \$39
- ALL THREE #701, #702 & #704 ..... NOW \$49

Add \$2.50 shipping and handling — \$4.50 for Canadian orders  
We also offer quantity Discounts on 5 or more units

**FREE** Reprint of Radio Electronics article (February 1984) on Building Your Own **CABLE TV DESCRAMBLER** with any purchase of above.

**60-CHANNEL  
CABLE  
CONVERTER**  
WITH INFRARED REMOTE CONTROL



SC-60R CONVERTER.....\$69.95

Thousands of these converters sold nationally for \$119.95  
We offer you this same type of converter for only \$69.95  
All converters are NEW, with Full manufacturer's WARRANTY.

**FEATURES:**

- Full 60 Channel Capability
- Cordless Infrared remote control
- Ultra-Stable Synthesized tuning
- Microprocessor controlled PLL
- Works on all TV models, channel 3 output
- Standard/HRC Switch for compatibility with all Cable Systems
- Will work with all types of external descramblers

Add \$3.50 Shipping and Handling  
\$4.50 on Canadian Orders

**ORDER  
TOLL FREE**

**1-800-227-8529**



inside MA 617-695-8699  
VISA, MASTERCARD or C.O.D.



**J & W  
ELECTRONICS, INC.**

6 Wilkins Dr., Suite 207  
Plainville MA., 02762



# -80-34-453-

AK, Puerto Rico 218-681.6674 Telex - 62277614 FAX - 218-681-3380 TWX - 913056882 DIGI KEY CORP

**NATIONAL SEMICONDUCTOR • PANASONIC  
OK MACHINE • EWC, INC. • AVERSIL • AD  
EAC, INC. • J. W. MILLER • INTERTECH  
E. F. JOHNSON • ATLANTIC SEMICONDUCTOR**

**256K (262,144 x 1) DRAM 150NS \$5.70/1; \$39.95/9**

**Factory Firsts**

## INTEGRATED CIRCUITS

725 Pin TTL	74ALS100	74ALS101	74ALS102	74ALS103	74ALS104	74ALS105	74ALS106	74ALS107	74ALS108	74ALS109	74ALS110	74ALS111	74ALS112	74ALS113	74ALS114	74ALS115	74ALS116	74ALS117	74ALS118	74ALS119	74ALS120	74ALS121	74ALS122	74ALS123	74ALS124	74ALS125	74ALS126	74ALS127	74ALS128	74ALS129	74ALS130	74ALS131	74ALS132	74ALS133	74ALS134	74ALS135	74ALS136	74ALS137	74ALS138	74ALS139	74ALS140	74ALS141	74ALS142	74ALS143	74ALS144	74ALS145	74ALS146	74ALS147	74ALS148	74ALS149	74ALS150	74ALS151	74ALS152	74ALS153	74ALS154	74ALS155	74ALS156	74ALS157	74ALS158	74ALS159	74ALS160	74ALS161	74ALS162	74ALS163	74ALS164	74ALS165	74ALS166	74ALS167	74ALS168	74ALS169	74ALS170	74ALS171	74ALS172	74ALS173	74ALS174	74ALS175	74ALS176	74ALS177	74ALS178	74ALS179	74ALS180	74ALS181	74ALS182	74ALS183	74ALS184	74ALS185	74ALS186	74ALS187	74ALS188	74ALS189	74ALS190	74ALS191	74ALS192	74ALS193	74ALS194	74ALS195	74ALS196	74ALS197	74ALS198	74ALS199
-------------	----------	----------	----------	----------	----------	----------	----------	----------	----------	----------	----------	----------	----------	----------	----------	----------	----------	----------	----------	----------	----------	----------	----------	----------	----------	----------	----------	----------	----------	----------	----------	----------	----------	----------	----------	----------	----------	----------	----------	----------	----------	----------	----------	----------	----------	----------	----------	----------	----------	----------	----------	----------	----------	----------	----------	----------	----------	----------	----------	----------	----------	----------	----------	----------	----------	----------	----------	----------	----------	----------	----------	----------	----------	----------	----------	----------	----------	----------	----------	----------	----------	----------	----------	----------	----------	----------	----------	----------	----------	----------	----------	----------	----------	----------	----------	----------	----------	----------	----------	----------

## 74100 CMOS

74ALS200	74ALS201	74ALS202	74ALS203	74ALS204	74ALS205	74ALS206	74ALS207	74ALS208	74ALS209	74ALS210	74ALS211	74ALS212	74ALS213	74ALS214	74ALS215	74ALS216	74ALS217	74ALS218	74ALS219	74ALS220	74ALS221	74ALS222	74ALS223	74ALS224	74ALS225	74ALS226	74ALS227	74ALS228	74ALS229	74ALS230	74ALS231	74ALS232	74ALS233	74ALS234	74ALS235	74ALS236	74ALS237	74ALS238	74ALS239	74ALS240	74ALS241	74ALS242	74ALS243	74ALS244	74ALS245	74ALS246	74ALS247	74ALS248	74ALS249	74ALS250	74ALS251	74ALS252	74ALS253	74ALS254	74ALS255	74ALS256	74ALS257	74ALS258	74ALS259	74ALS260	74ALS261	74ALS262	74ALS263	74ALS264	74ALS265	74ALS266	74ALS267	74ALS268	74ALS269	74ALS270	74ALS271	74ALS272	74ALS273	74ALS274	74ALS275	74ALS276	74ALS277	74ALS278	74ALS279	74ALS280	74ALS281	74ALS282	74ALS283	74ALS284	74ALS285	74ALS286	74ALS287	74ALS288	74ALS289	74ALS290	74ALS291	74ALS292	74ALS293	74ALS294	74ALS295	74ALS296	74ALS297	74ALS298	74ALS299	74ALS300
----------	----------	----------	----------	----------	----------	----------	----------	----------	----------	----------	----------	----------	----------	----------	----------	----------	----------	----------	----------	----------	----------	----------	----------	----------	----------	----------	----------	----------	----------	----------	----------	----------	----------	----------	----------	----------	----------	----------	----------	----------	----------	----------	----------	----------	----------	----------	----------	----------	----------	----------	----------	----------	----------	----------	----------	----------	----------	----------	----------	----------	----------	----------	----------	----------	----------	----------	----------	----------	----------	----------	----------	----------	----------	----------	----------	----------	----------	----------	----------	----------	----------	----------	----------	----------	----------	----------	----------	----------	----------	----------	----------	----------	----------	----------	----------	----------	----------	----------	----------	----------

## 74800 TTL

74ALS300	74ALS301	74ALS302	74ALS303	74ALS304	74ALS305	74ALS306	74ALS307	74ALS308	74ALS309	74ALS310	74ALS311	74ALS312	74ALS313	74ALS314	74ALS315	74ALS316	74ALS317	74ALS318	74ALS319	74ALS320	74ALS321	74ALS322	74ALS323	74ALS324	74ALS325	74ALS326	74ALS327	74ALS328	74ALS329	74ALS330	74ALS331	74ALS332	74ALS333	74ALS334	74ALS335	74ALS336	74ALS337	74ALS338	74ALS339	74ALS340	74ALS341	74ALS342	74ALS343	74ALS344	74ALS345	74ALS346	74ALS347	74ALS348	74ALS349	74ALS350	74ALS351	74ALS352	74ALS353	74ALS354	74ALS355	74ALS356	74ALS357	74ALS358	74ALS359	74ALS360	74ALS361	74ALS362	74ALS363	74ALS364	74ALS365	74ALS366	74ALS367	74ALS368	74ALS369	74ALS370	74ALS371	74ALS372	74ALS373	74ALS374	74ALS375	74ALS376	74ALS377	74ALS378	74ALS379	74ALS380	74ALS381	74ALS382	74ALS383	74ALS384	74ALS385	74ALS386	74ALS387	74ALS388	74ALS389	74ALS390	74ALS391	74ALS392	74ALS393	74ALS394	74ALS395	74ALS396	74ALS397	74ALS398	74ALS399	74ALS400
----------	----------	----------	----------	----------	----------	----------	----------	----------	----------	----------	----------	----------	----------	----------	----------	----------	----------	----------	----------	----------	----------	----------	----------	----------	----------	----------	----------	----------	----------	----------	----------	----------	----------	----------	----------	----------	----------	----------	----------	----------	----------	----------	----------	----------	----------	----------	----------	----------	----------	----------	----------	----------	----------	----------	----------	----------	----------	----------	----------	----------	----------	----------	----------	----------	----------	----------	----------	----------	----------	----------	----------	----------	----------	----------	----------	----------	----------	----------	----------	----------	----------	----------	----------	----------	----------	----------	----------	----------	----------	----------	----------	----------	----------	----------	----------	----------	----------	----------	----------	----------

## 74ALS400 CMOS

74ALS400	74ALS401	74ALS402	74ALS403	74ALS404	74ALS405	74ALS406	74ALS407	74ALS408	74ALS409	74ALS410	74ALS411	74ALS412	74ALS413	74ALS414	74ALS415	74ALS416	74ALS417	74ALS418	74ALS419	74ALS420	74ALS421	74ALS422	74ALS423	74ALS424	74ALS425	74ALS426	74ALS427	74ALS428	74ALS429	74ALS430	74ALS431	74ALS432	74ALS433	74ALS434	74ALS435	74ALS436	74ALS437	74ALS438	74ALS439	74ALS440	74ALS441	74ALS442	74ALS443	74ALS444	74ALS445	74ALS446	74ALS447	74ALS448	74ALS449	74ALS450	74ALS451	74ALS452	74ALS453	74ALS454	74ALS455	74ALS456	74ALS457	74ALS458	74ALS459	74ALS460	74ALS461	74ALS462	74ALS463	74ALS464	74ALS465	74ALS466	74ALS467	74ALS468	74ALS469	74ALS470	74ALS471	74ALS472	74ALS473	74ALS474	74ALS475	74ALS476	74ALS477	74ALS478	74ALS479	74ALS480	74ALS481	74ALS482	74ALS483	74ALS484	74ALS485	74ALS486	74ALS487	74ALS488	74ALS489	74ALS490	74ALS491	74ALS492	74ALS493	74ALS494	74ALS495	74ALS496	74ALS497	74ALS498	74ALS499	74ALS500
----------	----------	----------	----------	----------	----------	----------	----------	----------	----------	----------	----------	----------	----------	----------	----------	----------	----------	----------	----------	----------	----------	----------	----------	----------	----------	----------	----------	----------	----------	----------	----------	----------	----------	----------	----------	----------	----------	----------	----------	----------	----------	----------	----------	----------	----------	----------	----------	----------	----------	----------	----------	----------	----------	----------	----------	----------	----------	----------	----------	----------	----------	----------	----------	----------	----------	----------	----------	----------	----------	----------	----------	----------	----------	----------	----------	----------	----------	----------	----------	----------	----------	----------	----------	----------	----------	----------	----------	----------	----------	----------	----------	----------	----------	----------	----------	----------	----------	----------	----------	----------

## 74ALS500 TTL

74ALS500	74ALS501	74ALS502	74ALS503	74ALS504	74ALS505	74ALS506	74ALS507	74ALS508	74ALS509	74ALS510	74ALS511	74ALS512	74ALS513	74ALS514	74ALS515	74ALS516	74ALS517	74ALS518	74ALS519	74ALS520	74ALS521	74ALS522	74ALS523	74ALS524	74ALS525	74ALS526	74ALS527	74ALS528	74ALS529	74ALS530	74ALS531	74ALS532	74ALS533	74ALS534	74ALS535	74ALS536	74ALS537	74ALS538	74ALS539	74ALS540	74ALS541	74ALS542	74ALS543	74ALS544	74ALS545	74ALS546	74ALS547	74ALS548	74ALS549	74ALS550	74ALS551	74ALS552	74ALS553	74ALS554	74ALS555	74ALS556	74ALS557	74ALS558	74ALS559	74ALS560	74ALS561	74ALS562	74ALS563	74ALS564	74ALS565	74ALS566	74ALS567	74ALS568	74ALS569	74ALS570	74ALS571	74ALS572	74ALS573	74ALS574	74ALS575	74ALS576	74ALS577	74ALS578	74ALS579	74ALS580	74ALS581	74ALS582	74ALS583	74ALS584	74ALS585	74ALS586	74ALS587	74ALS588	74ALS589	74ALS590	74ALS591	74ALS592	74ALS593	74ALS594	74ALS595	74ALS596	74ALS597	74ALS598	74ALS599	74ALS600
----------	----------	----------	----------	----------	----------	----------	----------	----------	----------	----------	----------	----------	----------	----------	----------	----------	----------	----------	----------	----------	----------	----------	----------	----------	----------	----------	----------	----------	----------	----------	----------	----------	----------	----------	----------	----------	----------	----------	----------	----------	----------	----------	----------	----------	----------	----------	----------	----------	----------	----------	----------	----------	----------	----------	----------	----------	----------	----------	----------	----------	----------	----------	----------	----------	----------	----------	----------	----------	----------	----------	----------	----------	----------	----------	----------	----------	----------	----------	----------	----------	----------	----------	----------	----------	----------	----------	----------	----------	----------	----------	----------	----------	----------	----------	----------	----------	----------	----------	----------	----------

## 74ALS600 CMOS

74ALS600	74ALS601	74ALS602	74ALS603	74ALS604	74ALS605	74ALS606	74ALS607	74ALS608	74ALS609	74ALS610	74ALS611	74ALS612	74ALS613	74ALS614	74ALS615	74ALS616	74ALS617	74ALS618	74ALS619	74ALS620	74ALS621	74ALS622	74ALS623	74ALS624	74ALS625	74ALS626	74ALS627	74ALS628	74ALS629	74ALS630	74ALS631	74ALS632	74ALS633	74ALS634	74ALS635	74ALS636	74ALS637	74ALS638	74ALS639	74ALS640	74ALS641	74ALS642	74ALS643	74ALS644	74ALS645	74ALS646	74ALS647	74ALS648	74ALS649	74ALS650	74ALS651	74ALS652	74ALS653	74ALS654	74ALS655	74ALS656	74ALS657	74ALS658	74ALS659	74ALS660	74ALS661	74ALS662	74ALS663	74ALS664	74ALS665	74ALS666	74ALS667	74ALS668	74ALS669	74ALS670	74ALS671	74ALS672	74ALS673	74ALS674	74ALS675	74ALS676	74ALS677	74ALS678	74ALS679	74ALS680	74ALS681	74ALS682	74ALS683	74ALS684	74ALS685	74ALS686	74ALS687	74ALS688	74ALS689	74ALS690	74ALS691	74ALS692	74ALS693	74ALS694	74ALS695	74ALS696	74ALS697	74ALS698	74ALS699	74ALS700
----------	----------	----------	----------	----------	----------	----------	----------	----------	----------	----------	----------	----------	----------	----------	----------	----------	----------	----------	----------	----------	----------	----------	----------	----------	----------	----------	----------	----------	----------	----------	----------	----------	----------	----------	----------	----------	----------	----------	----------	----------	----------	----------	----------	----------	----------	----------	----------	----------	----------	----------	----------	----------	----------	----------	----------	----------	----------	----------	----------	----------	----------	----------	----------	----------	----------	----------	----------	----------	----------	----------	----------	----------	----------	----------	----------	----------	----------	----------	----------	----------	----------	----------	----------	----------	----------	----------	----------	----------	----------	----------	----------	----------	----------	----------	----------	----------	----------	----------	----------	----------

## 74ALS700 CMOS

74ALS700	74ALS701	74ALS702	74ALS703	74ALS704	74ALS705	74ALS706	74ALS707	74ALS708	74ALS709	74ALS710	74ALS711	74ALS712	74ALS713	74ALS714	74ALS715	74ALS716	74ALS717	74ALS718	74ALS719	74ALS720	74ALS721	74ALS722	74ALS723	74ALS724	74ALS725	74ALS726	74ALS727	74ALS728	74ALS729	74ALS730	74ALS731	74ALS732	74ALS733	74ALS734	74ALS735	74ALS736	74ALS737	74ALS738	74ALS739	74ALS740	74ALS741	74ALS742	74ALS743	74ALS744	74ALS745	74ALS746	74ALS747	74ALS748	74ALS749	74ALS750	74ALS751	74ALS752	74ALS753	74ALS754	74ALS755	74ALS756	74ALS757	74ALS758	74ALS759	74ALS760	74ALS761	74ALS762	74ALS763	74ALS764	74ALS765	74ALS766	74ALS767	74ALS768	74ALS769	74ALS770	74ALS771	74ALS772	74ALS773	74ALS774	74ALS775	74ALS776	74ALS777	74ALS778	74ALS779	74ALS780	74ALS781	74ALS782	74ALS783	74ALS784	74ALS785	74ALS786	74ALS787	74ALS788	74ALS789	74ALS790	74ALS791	74ALS792	74ALS793	74ALS794	74ALS795	74ALS796	74ALS797	74ALS798	74ALS799	74ALS800
----------	----------	----------	----------	----------	----------	----------	----------	----------	----------	----------	----------	----------	----------	----------	----------	----------	----------	----------	----------	----------	----------	----------	----------	----------	----------	----------	----------	----------	----------	----------	----------	----------	----------	----------	----------	----------	----------	----------	----------	----------	----------	----------	----------	----------	----------	----------	----------	----------	----------	----------	----------	----------	----------	----------	----------	----------	----------	----------	----------	----------	----------	----------	----------	----------	----------	----------	----------	----------	----------	----------	----------	----------	----------	----------	----------	----------	----------	----------	----------	----------	----------	----------	----------	----------	----------	----------	----------	----------	----------	----------	----------	----------	----------	----------	----------	----------	----------	----------	----------	----------

## 74ALS800 CMOS

74ALS800	74ALS801	74ALS802	74ALS803	74ALS804	74ALS805	74ALS806	74ALS807	74ALS808	74ALS809	74ALS810	74ALS811	74ALS812	74ALS813	74ALS814	74ALS815	74ALS816	74ALS817	74ALS818	74ALS819	74ALS820	74ALS821	74ALS822	74ALS823	74ALS824	74ALS825	74ALS826	74ALS827	74ALS828	74ALS829	74ALS830	74ALS831	74ALS832	74ALS833	74ALS834	74ALS835	74ALS836	74ALS837	74ALS838	74ALS839	74ALS840	74ALS841	74ALS842	74ALS843	74ALS844	74ALS845	74ALS846	74ALS847	74ALS848	74ALS849	74ALS850	74ALS851	74ALS852	74ALS853	74ALS854	74ALS855	74ALS856	74ALS857	74ALS858	74ALS859	74ALS860	74ALS861	74ALS862	74ALS863	74ALS864	74ALS865	74ALS866	74ALS867	74ALS868	74ALS869	74ALS870	74ALS871	74ALS872	74ALS873	74ALS874	74ALS875	74ALS876	74ALS877	74ALS878	74ALS879	74ALS880	74ALS881	74ALS882	74ALS883	74ALS884	74ALS885	74ALS886	74ALS887	74ALS888	74ALS889	74ALS890	74ALS891	74ALS892	74ALS893	74ALS894	74ALS895	74ALS896	74ALS897	74ALS898	74ALS899	74ALS900
----------	----------	----------	----------	----------	----------	----------	----------	----------	----------	----------	----------	----------	----------	----------	----------	----------	----------	----------	----------	----------	----------	----------	----------	----------	----------	----------	----------	----------	----------	----------	----------	----------	----------	----------	----------	----------	----------	----------	----------	----------	----------	----------	----------	----------	----------	----------	----------	----------	----------	----------	----------	----------	----------	----------	----------	----------	----------	----------	----------	----------	----------	----------	----------	----------	----------	----------	----------	----------	----------	----------	----------	----------	----------	----------	----------	----------	----------	----------	----------	----------	----------	----------	----------	----------	----------	----------	----------	----------	----------	----------	----------	----------	----------	----------	----------	----------	----------	----------	----------	----------

## 74ALS900 CMOS

74ALS900	74ALS901	74ALS902	74ALS903	74ALS904	74ALS905	74ALS906	74ALS907	74ALS908	74ALS909	74ALS910	74ALS911	74ALS912	74ALS913	74ALS914	74ALS915	74ALS916	74ALS917	74ALS918	74ALS919	74ALS920	74ALS921	74ALS922	74ALS923	74ALS924	74ALS925	74ALS926	74ALS927	74ALS928	74ALS929	74ALS930	74ALS931	74ALS932	74ALS933	74ALS934	74ALS935	74ALS936	74ALS937	74ALS938	74ALS939	74ALS940	74ALS941	74ALS942	74ALS943	74ALS944	74ALS945	74ALS946	74ALS947	74ALS948	74ALS949	74ALS950	74ALS951	74ALS952	74ALS953	74ALS954	74ALS955	74ALS956	74ALS957	74ALS958	74ALS959	74ALS960	74ALS961	74ALS962	74ALS963	74ALS964	74ALS965	74ALS966	74ALS967	74ALS968	74ALS969	74ALS970	74ALS971	74ALS972	74ALS973	74ALS974	74ALS975	74ALS976	74ALS977	74ALS978	74ALS979	74ALS980	74ALS981	74ALS982	74ALS983	74ALS984	74ALS985	74ALS986	74ALS987	74ALS988	74ALS989	74ALS990	74ALS991	74ALS992	74ALS993	74ALS994	74ALS995	74ALS996	74ALS997	74ALS998	74ALS999	74ALS1000
----------	----------	----------	----------	----------	----------	----------	----------	----------	----------	----------	----------	----------	----------	----------	----------	----------	----------	----------	----------	----------	----------	----------	----------	----------	----------	----------	----------	----------	----------	----------	----------	----------	----------	----------	----------	----------	----------	----------	----------	----------	----------	----------	----------	----------	----------	----------	----------	----------	----------	----------	----------	----------	----------	----------	----------	----------	----------	----------	----------	----------	----------	----------	----------	----------	----------	----------	----------	----------	----------	----------	----------	----------	----------	----------	----------	----------	----------	----------	----------	----------	----------	----------	----------	----------	----------	----------	----------	----------	----------	----------	----------	----------	----------	----------	----------	----------	----------	----------	----------	-----------

## 74ALS1000 CMOS

74ALS1000	74ALS1001	74ALS1002	74ALS1003	74ALS1004	74ALS1005	74ALS1006	74ALS1007	74ALS1008	74ALS1009	74ALS1010	74ALS1011	74ALS1012	74ALS1013	74ALS1014	74ALS1015	74ALS1016	74ALS1017	74
-----------	-----------	-----------	-----------	-----------	-----------	-----------	-----------	-----------	-----------	-----------	-----------	-----------	-----------	-----------	-----------	-----------	-----------	----

# ADVERTISING INDEX

RADIO-ELECTRONICS does not assume any responsibility for errors that may appear in the index below.

Free Information Number	Page		Page		Page	
81	A.I.S. Satellite	77	82	Digi-Key	113	
108	AMC Sales	90	—	Digital Research Computers	114	
76	AP Products	34	204	ESI	75	
107	All Electronics	103	—	Electronic Technology Today	76.CD10	
187	All-Crystal Displays	76	—	Electronics Book Club	39	
—	Amazing Devices	98	120	Elephant Electronics	77	
84	Appliance Service	76	186	Esoft Software	CD16	
197	Augat	38	111,176	Etronix	28,91	
77	B&K Precision	26	100	Firestik II	93	
—	BP	CV3	121	Fluke Manufacturing	17	
53	BUYUS	77	—	Fordham Radio	CV4	
98	Beckman Industrial	79	196	Fox Antennas	86	
85	Blue Star Industries	77	—	Grantham College of Engineering	68	
109	C & S Sales	71	—	HW Sams	28	
—	C.O.M.B.	27	62	Hameg	89	
—	CIE	18	86	Heath	33	
182	Craig Laboratories	22	195	Intek Electronics	76	
89	Cameo Enterprises	114	65	J&W	112	
—	Command Productions	93	59	JDR Instruments	13	
79	Communications Electronics	3	113,177	JDR Microdevices	104,105	
205	Cook's Institute	91	178,179	JDR Microdevices	106,107	
—	Coop's Satellite Digest	73	180	JDR Microdevices	108	
125	Copper Electronics	22	114	Jameco	100,101	
192	Crosley	77	115	Jensen Tools	77	
127	Deco Industries	76,77	—	Joseph Electronics	15	
95	Dick Smith Electronics	110,111				
				87	MCM Electronics	109
				93	Mark V. Electronics	102
				—	McGraw Hill Book Club	80
				—	McGraw Hill/(CED)	31
				184	Mercer	25
				193	Microprocessors Unltd.	CD16
				—	NRI	8
				110	Omnitron	36
				—	Pacific Cable	97
				96	Probemaster	7
				126	RAG Electronics	5,23
				201	RCA D&SP	16
				78	Radio Shack	99
				185	Salen Enterprises	91
				188,189	Sencore	35,37
				199	Siber Hegner	14
				206	Simpson	CD4
				198	Star Circuits	77
				92	Tektronix	CV2
				202	Transleteronic	90
				102	Trio-Kenwood	85
				183	United Electronic Supply	87
				66	W.S. Jenks	26
				194,203	Wavetek	24
				103	Wm B Allen	32

ALL SALES SUBJECT TO THE TERMS OF OUR 90 DAY LIMITED WARRANTY. FREE COPY UPON REQUEST.

## THE NEW 65/9028 VT ANSI VIDEO TERMINAL BOARD!

\* FROM LINGER ENTERPRISES \*

A second generation, low cost, high performance, mini sized, single board for making your own RS232 Video Terminal. Use as a computer console or with a MODEM for hook up to any of the telephone-line computer services.

### FEATURES:

- \* Uses the new SMC 9028 Video Controller Chip coupled with a 6502A CPU.
- \* RS-232 at 16 Baud Rates from 50 to 19,200
- \* On board printer port!
- \* 24 X 80 format (50/60 Hz).
- \* For 15,750 Hz (Horiz.) monitors.
- \* 3 Terminal Modes: H-19, ADM3A, and ANSI X 3.64-1979
- \* Wide and thin-line graphics.
- \* White characters on black background or reversed.
- \* Character Attributes: De-Inten, Inverse or Underline.
- \* Low Power: 5VDC @ .7A, ± 12VDC @ 20MA.
- \* Mini size: 6.5 X 5 inches.
- \* Composite or split video.
- \* 5 X 8 Dot Matrix characters (U/L case).
- \* Answer back capability.
- \* Battery backed up status memory.
- \* For ASCII parallel keyboard.

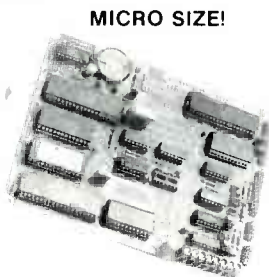

**\$99<sup>95</sup>**  
(Full Kit)

SOURCE DISKETTE:  
PC/XT FORMAT  
5 1/4 IN. \$15

ADD \$40 FOR A&T

## Digital Research Computers (OF TEXAS)

P.O. BOX 381450 • DUNCANVILLE TX 75138 • (214) 225-2309

Call or write for a free catalog on Z-80 or 6809 Single Board Computers, SS-50 Boards, and other S-100 products.

TERMS: Add \$3.00 postage. We pay balance. Orders under \$15 add 75¢ handling. No C.O.D. We accept Visa and MasterCard. Texas Res. add 5-1/8% Tax. Foreign orders (except Canada) add 20% P & H. Orders over \$50 add 85¢ for insurance.

# STUN GUN



# EQUALIZER

- The ultimate non-lethal defense weapon.
- In five seconds can immobilize your attacker, even through heavy clothing.
- Discharges over forty thousand volts of electricity from a nine volt nickel-cadmium battery.
- \$39.95, Mass 5% sales tax, \$3.00 shipping and handling.

**1-800-522-2636**

FOR ORDERS ONLY  
617-871-5611  
FOR INFORMATION

**Cameo Enterprises, Inc.**  
P.O. Box 63, Accord, MA 02018

CIRCLE 89 ON FREE INFORMATION CARD

Gernsback Publications, Inc.  
500-B Bi-County Blvd.  
Farmingdale, NY 11735  
(516) 293-3000  
President: Larry Steckler  
Vice President: Cathy Steckler

For Advertising ONLY

516-293-3000

Larry Steckler

publisher

Arline Fishman

advertising director

Shelli Weinman

advertising associate

Lisa Strassman

credit manager

Christina Estrada

advertising assistant

### SALES OFFICES

#### EAST/SOUTHEAST

Stanley Levitan

Eastern Sales Manager

Radio-Electronics

259-23 57th Avenue

Little Neck, NY 11362

718-428-6037, 516-293-3000

#### MIDWEST/

Texas/Arkansas/Okla.

Ralph Bergen

Midwest Sales Manager

Radio-Electronics

540 Frontage Road—Suite 339

Northfield, IL 60093

312-446-1444

#### PACIFIC COAST/

Mountain States

Marvin Green

Pacific Sales Manager

Radio-Electronics

15335 Morrison St.—Suite 227

Sherman Oaks, CA 91403

818-986-2001

# A Successful Union Of Traditional And Contemporary Design

The beauty, charm, simplicity of the Oak File Cabinet and the comfortable modern style of the Back Chair are more than just complementary pieces of furniture. They're handsome pieces which perform necessary functions in your home or business. Whether they stand united or alone they add a special dimension to your living area.

## An Opulent Oak File

The two drawer oak file is made of solid wood with a beautifully polished oak veneer surface. Its pleasing simple lines blend with any interior bringing back the warmth and tradition of its early American counterparts. This handsome organizer has drawers which are 13 inches deep which fits standard files hanging from steel rails. Dimensions: 28-1/4"H x 16-1/4"W x 17"D.

Model **\$89<sup>95</sup>**  
CF-22



## Discover The Comfort Of The Back Chair

Delight in the comfort and mobility of the Adjustable Back Chair with Casters. The Back Chair helps alleviate the discomfort of the conventional chair by changing the stress points on the body. Instead of forcing your lower back to support your weight by sitting at a 90° angle, the Back Chair balances your weight proportionally through your lower body and legs. In this new position your spine straightens naturally; you're able to relax and concentrate more efficiently. The Back Chair is user friendly and a viable alternative for those long hours at the computer, typewriter, desk or drawing board. The seat can be raised or lowered to accommodate each member of your household or business. Its handsome oak veneer finish allows it to blend with any decor.

Model CH-97  
**\$39<sup>95</sup>**



We Accept Visa, MasterCard  
and American Express.

SEND ORDER TO: **bp** 260 Motor Parkway, Hauppauge, NY 11788

Please send me \_\_\_\_\_ Back Chair(s) at \$39.95 ea.  
Add \$5.50 shipping charge for each piece. Total \_\_\_\_\_

Please send me \_\_\_\_\_ Oak File(s) at \$89.95 ea.  
Add \$10.50 shipping charge for each piece. Total \_\_\_\_\_

My Check or Money Order Is Enclosed.

Charge My Credit Card     Visa     MasterCard     Amex

Card # \_\_\_\_\_

Signature \_\_\_\_\_ Exp. Date \_\_\_\_\_

Telephone: (\_\_\_\_\_) \_\_\_\_\_

Name \_\_\_\_\_

Address \_\_\_\_\_

City \_\_\_\_\_ State \_\_\_\_\_ Zip \_\_\_\_\_

Phone Orders Call Toll FREE out of state **800-645-9152**  
NYS Toll FREE **800-832-1446 ext. 42**



# SCOPE 3½ DIGIT LCD MINI-METER WITH THE MAXI-SPECS

Small enough to fit in your shirt pocket

**\$29.95**  
ONLY Model DVM-630

Model CC-30 Deluxe  
Zippered Carrying Case \$4.50

- 0.5% DC accuracy
- 6 Functions, 19 Ranges
  - DC Voltage, 0.1 mV to 1000 V • DC Current, 0.1 uA to 2A • Resistance, 0.1 ohm to 2 M ohm • Diode Test • Battery Test
- Measures approx. 5 x 2¾ x 7/8 in.
- 300 hour battery life
- Automatic zero adjust
- Low battery indication
- Test leads included



## SCOPE HAND-HELD DIGITAL CAPACITANCE and MULTIMETERS

- 0.5% DC Accuracy
- Highest Quality
- Highest Performance
- Lowest Prices

**Model DCM-602**  
**\$69.95**

**3½ Digit Capacitance Meter**  
8 ranges with full scale values to 2000 uF  
**FEATURES** • Broad test range - 1 pF to 2000 uF • LSI circuit provides high reliability and durability • Lower power consumption • Crystal time base  
• Protected from charged capacitors  
• Frequency range - 800 Hz to 8 Hz

**Model DVM-634**  
**\$48.75**

7 functions, 32 ranges.  
Transistor measurement included.

### 3½ Digital Multimeters

**FEATURES** • DC Voltage 100 uV - 1000 V • AC Voltage 100 uV - 750 V • AC/DC Current 200 uA - 10 Amps • Resistance 20 Megohms • Capacitance (DVM 636/638) 1 pF - 20 uF • Overload Protection • Auto-decimal LCD readout • Polarity indication • 300 hour battery life with 9V transistor battery • Low battery indication

**Model DVM-638**  
**\$79.95**

11 functions, 38 ranges.  
Includes logic level detector, audible visual continuity, capacitance and conductance measurement.

**Model DVM-636**  
**\$62.75**

8 functions, 37 ranges.  
Capacitance measurement included.

ASK FOR FREE CATALOG.  
Money orders, checks accepted. C.O.D.'s require 25% deposit.



# Fordham

260 Motor Parkway, Hauppauge, NY 11788

Toll Free  
**800-645-9518**  
In NY State 800-832-1446

Service & Shipping Charge Schedule Continental U.S.A.	
FOR ORDERS	ADD
\$25-\$100	\$4.50
\$101-\$250	\$6.00
\$251-\$500	\$8.00
\$501-\$750	\$10.50
\$751-\$1,000	\$12.50
\$1,001-\$1,500	\$16.50
\$1,501-\$2,000	\$20.00
\$2,001 and Up.	\$25.00